

**Padded Beds  
“Limited” Warranty**

**Thank you for your recent purchase.**

**Full Replacement**

0-12 months

This warranty the original purchaser and is valid only when accompanied by the original purchaser’s sales receipt showing original date of purchase and location of purchase. Replacements under this warranty revert to the date of original purchase for future warranty. Maintain this warranty document and your sales receipt in a safe place.

This authorized dealer can accept or reject warranty claims based on its findings. This warranty applies in normal residential use only. Normal residential use only is described as using the product on a level surface with all legs touching the floor with an equal distribution of weight. The product is to be used with standard mattresses only. This warranty is invalid if the product is not used for its intended purpose. We can make substitutions as required of materials, components, and sub-components of comparable value and utility. We reserves the right to refuse service and invalidate the warranty when, upon inspection, the product failure is caused by factors other than defective workmanship or materials.

Manufacturing defects include when the product has become defective where it will not support the mattress properly.

Sales and use taxes, plus shipping and handling charges are the responsibility of the consumer. Consumer is required to deliver damaged product to the authorized dealer.

Certain items are not covered by this warranty. These include, but are not limited to the following:

1. Components subjected to abuse including abuse intended to simulate failure.
2. Damages caused by shipper, dealer, or installation crew such as scratches, dents, fabric tears etc.
3. Any part which merely exhibits normal wear yet functions essentially as new.
4. This disclaims liability for any aspect of installation and any inconvenience caused by a defective part of a component.
5. Tears, punctures, dents, or any damage caused by improper installation.
6. Items sold “as is” and Floor Model Units.
7. We warrants only the products listed at the top of this page. This warranty does not extend to any mattress that may be placed on the listed products.
8. Weight Capacity – King, California King, Queen, Double size – 700 Lbs. Twin size – 400 Lbs.

To make a claim, return the defective part along with your original sales receipt to an authorized dealer. If there is not a dealer in your area, send a copy of the original sales receipt, the defective product along with a brief description . All items must be sent freight prepaid.

Replacement will be made at the company’s option. This is the entire exclusive express limited warranty. The manufacturer neither makes nor is responsible for any other warranties, either expressed or implied, including those of retailing dealers. **Any and all liability for breach of warranty, as well as damages for incidental or consequential losses is expressly denied.**

**Platform Bed**  
**Assembly Instruction**  
Contains One Bed and Hardware

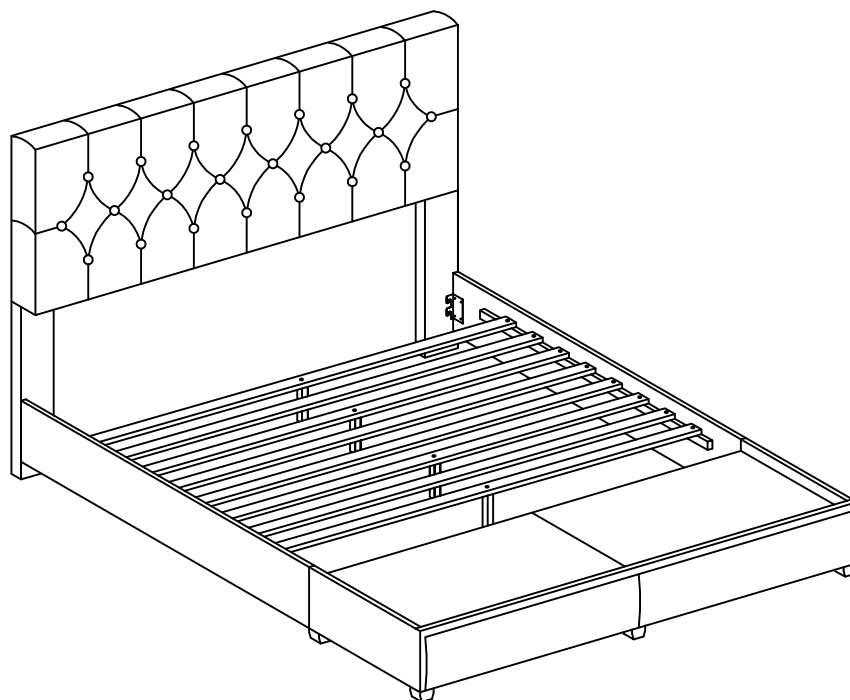

**IMPORTANT NOTE:**

Carefully remove all the parts from the box. Arrange on a flat surface and verify you have all of the following parts and hardware

**TOOLS REQUIRED:**  
Phillips Screwdriver

# PARTS LIST

**A. Headboard (1 pc)**

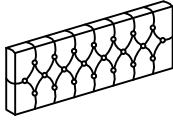

**B. Footboard (1 pc)**

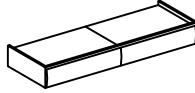

**C. Side Rail (2 pcs)**

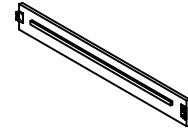

**D. Headboard Legs (2 pcs)**

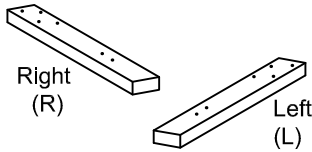

**E. Footboard Leg (5 pcs)**

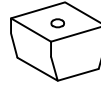

**F. Wood Slat System (1 pc)**

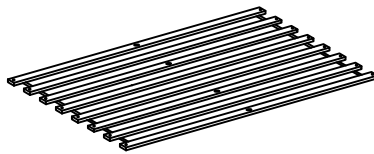

**G. Center Leg (4 pcs)**

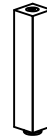

# HARDWARE LIST

**H. 30mm Bolt (8 pcs)**

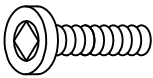

**I. 40mm Bolt (4 pcs)**

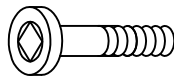

**J. 50mm Bolt (8 pcs)**

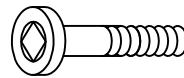

**K. 70mm Bolt (5 pcs)**

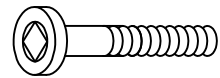

**L. Large Hex Key (1 pc)**



**M. Small Hex Key (1 pc)**

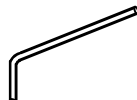

**N. 32mm Screw (16 pcs)**



**O. Spring Washer (8 pcs)**



**P. Flat Washer (8 pcs)**

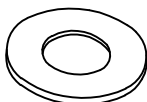

# ASSEMBLY INSTRUCTIONS

## STEP 1

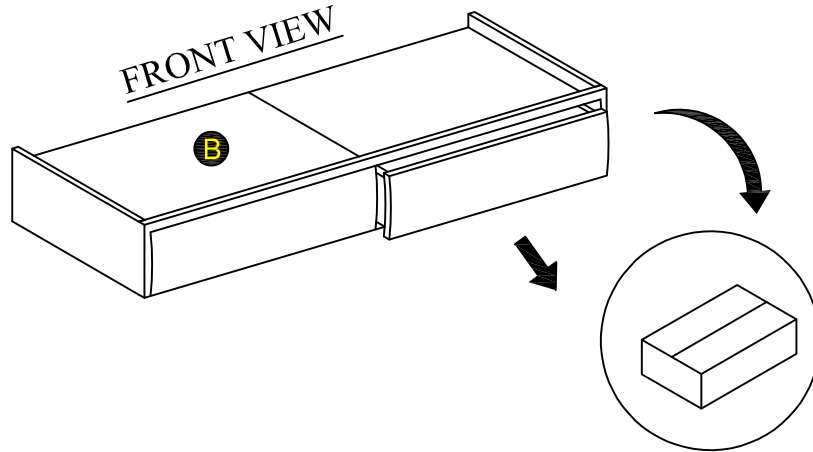

Open the footboard drawer (Part B), and remove all of the parts.

## STEP 2

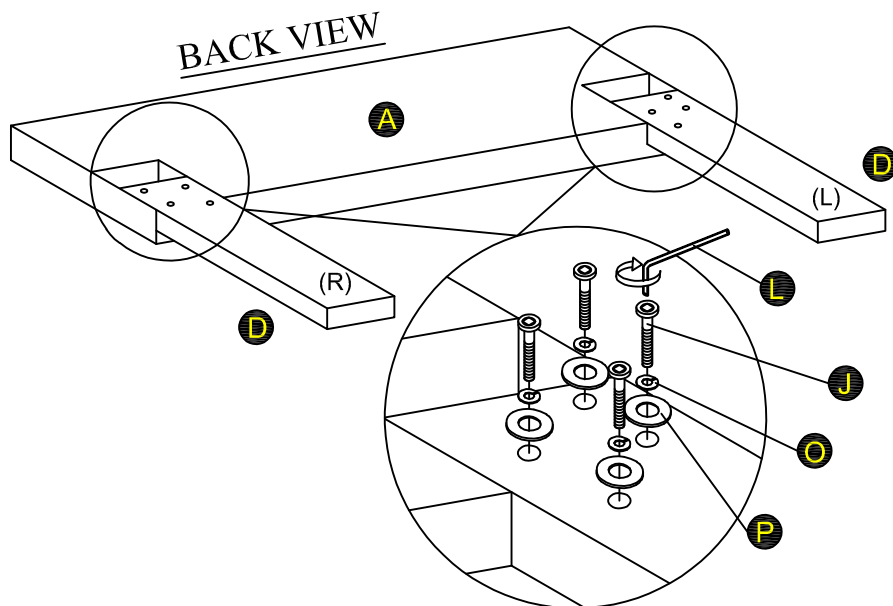

Attach Headboard Legs (Part D) to the Headboard (Part A) using four 50mm Bolts (Part J), four Spring Washers (Part O) and four Flat Washers (Part P) per leg. Secure tightly using Large Hex Key (Part L).

# ASSEMBLY INSTRUCTIONS

## STEP 3

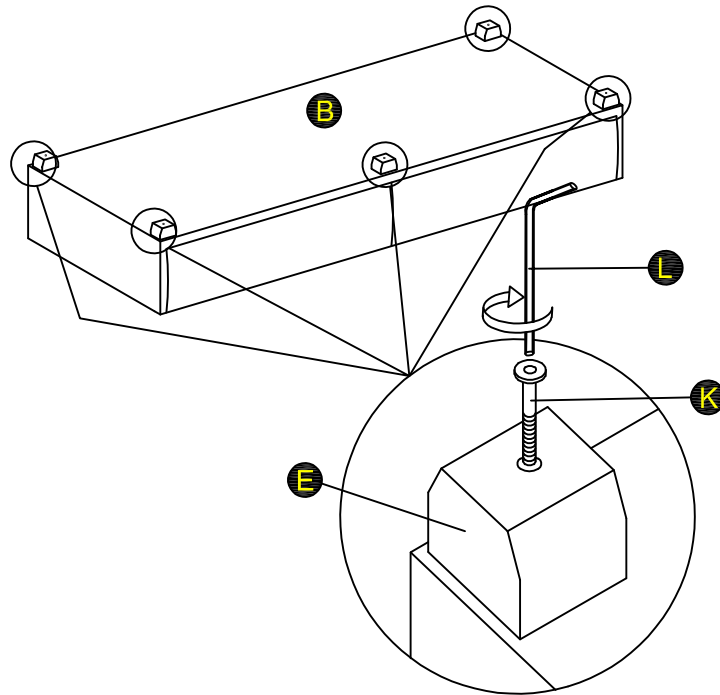

Attach the Footboard Legs (Part E) to the Footboard (Part B) using five 70mm Bolts (Part K) and Large Hex Key (Part L). Secure tightly.

## STEP 4

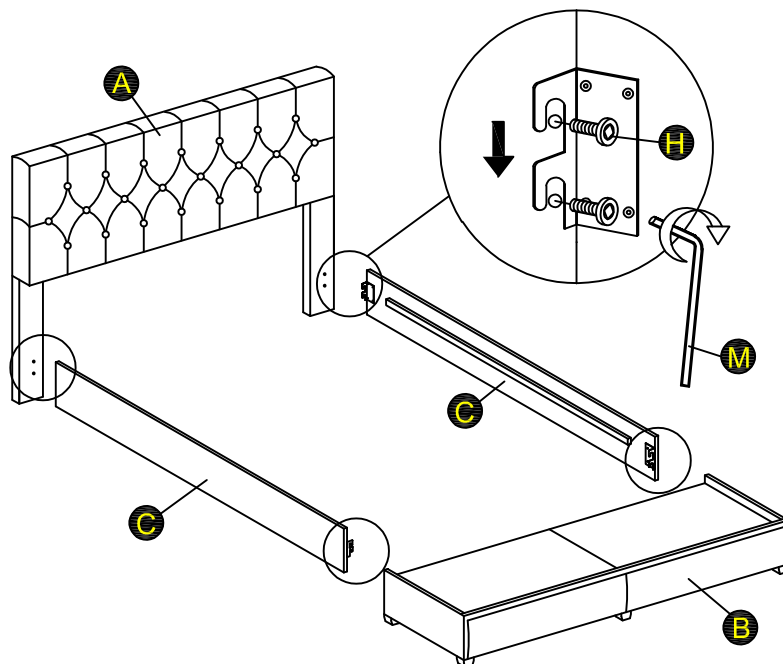

Attach the eight 30mm Bolts (Part H) to the headboard legs and footboard using the Small Hex Key (Part M). Do not tighten.

# ASSEMBLY INSTRUCTIONS

## STEP 5

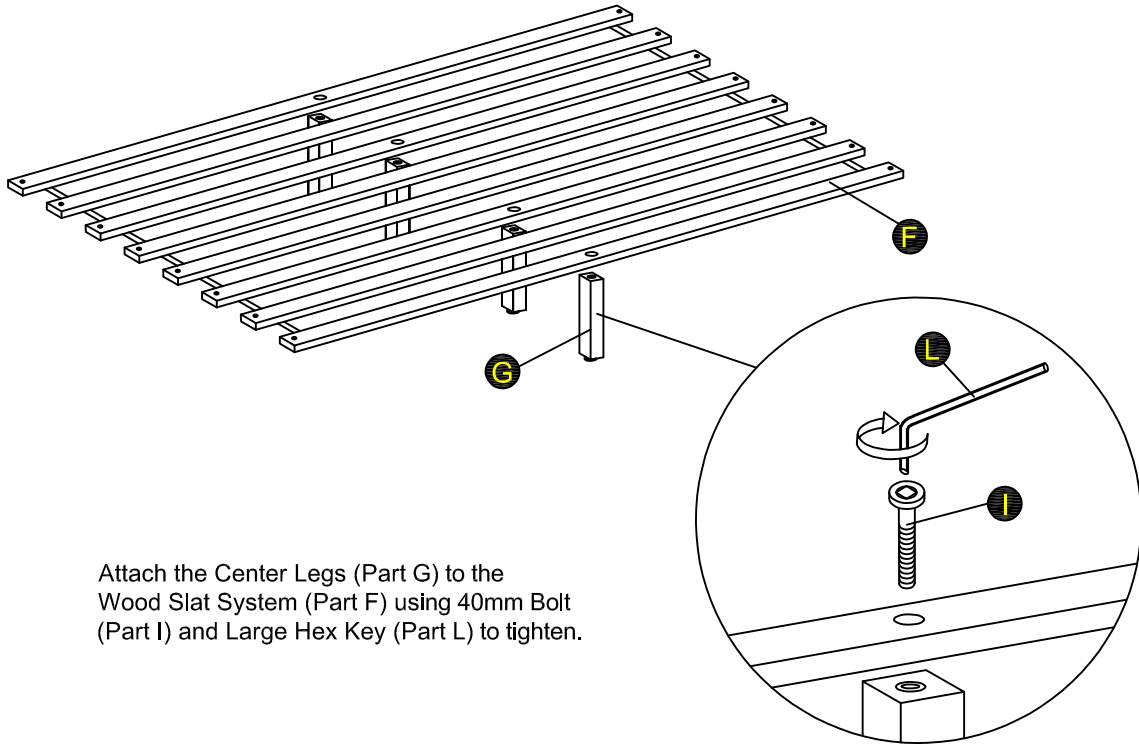

Attach the Center Legs (Part G) to the Wood Slat System (Part F) using 40mm Bolt (Part I) and Large Hex Key (Part L) to tighten.

## STEP 6

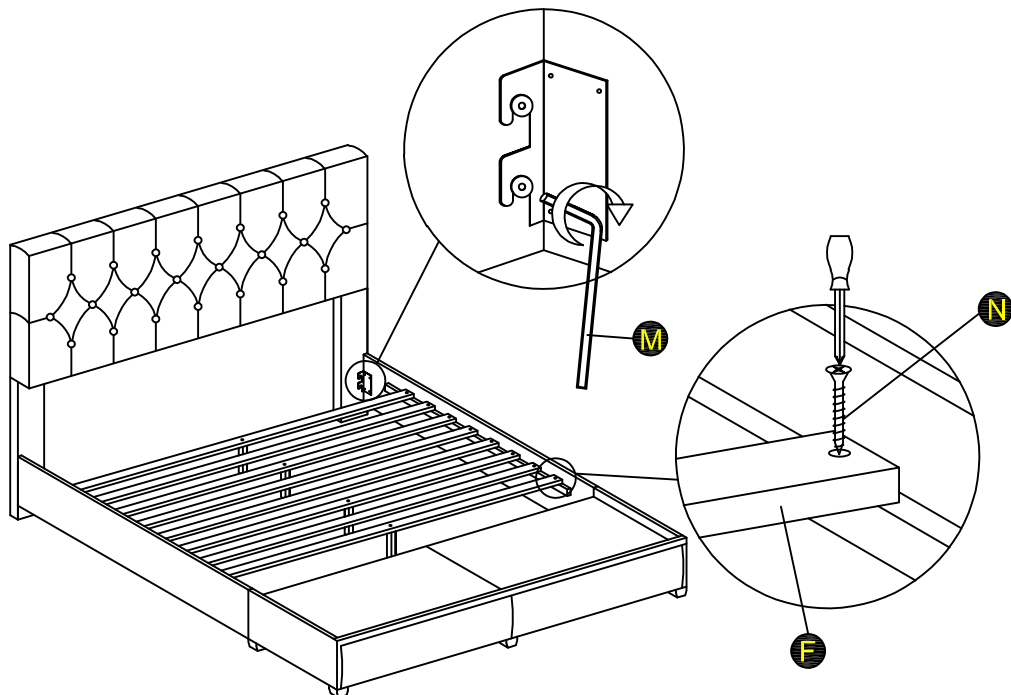

Place the eight slats into the bed as shown. Tighten the bolts on the headboard legs and footboard using Small Hex Key (Part M). Secure the 8 slats using sixteen Screws (Part N) and a Phillips Screwdriver. Your bed is now set up and ready for use. Your platform bed is now ready for use.