

118"x118"x79" Outdoor Pet Run Owner's Manual

Tip: Ship out as 1 Boxes
May Not arrive at the same time
24 Hours After-Sales Service

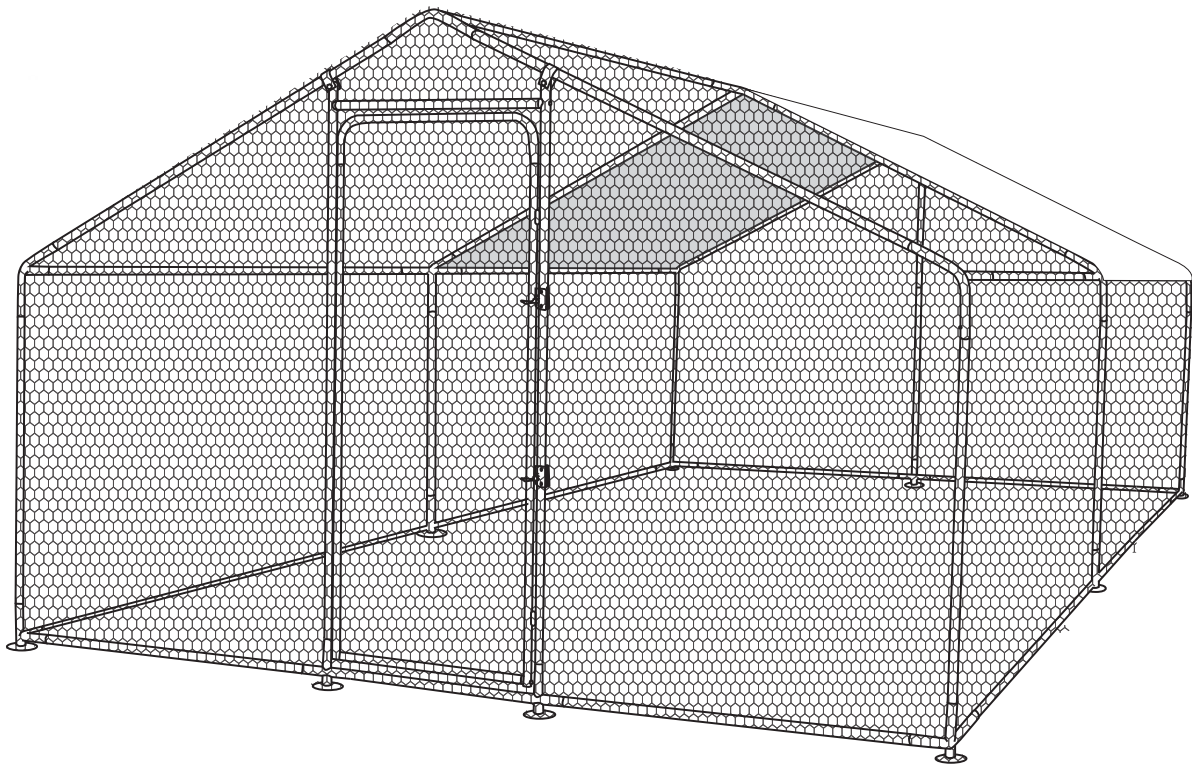

Watch the weather: Better select a calm day to install this item.
Teamwork: More partners to complete this item may be more efficient.
Tools: Basic tools are needed in assembly.

XOT09200PC

EN

Before You Begin

Owner's Manual

Before beginning construction, check local building codes regarding footings, location and other requirements. Study and understand this owner's manual. Important information and helpful tips will make your construction easier and more enjoyable.

Assembly Instructions

Instructions are supplied in this manual and contain all appropriate information for your building model. Review all instructions before you begin, and during assembly, follow the step sequence carefully for correct results.

Parts and Parts List

Check to be sure that you have all the necessary parts for building . Separate contents of the carton by the part number while reviewing parts list. The first few steps show how to join related parts to make larger sub assemblies which will be used later.

Familiarize yourself with the hardware and fasteners for easier use during construction. These are packaged within the carton. Note that extra fasteners have been supplied for your convenience.

Plan Ahead

Watch the Weather: Be sure the day you select to install your building is dry and calm. Do not attempt to assemble your building on a windy day.











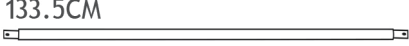

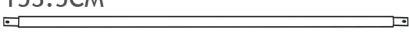

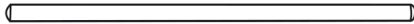
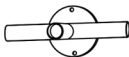

Teamwork: Whenever possible, two or more people should work together to assemble your building. One person can position parts or panels while the other is able to handle the fasteners and the tools.

Tools and Materials: These are some basic tools and materials you will need for the construction of your building. Decide which method of anchoring and the type of foundation you wish to use in order to form a complete list of the materials you will need.

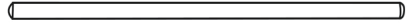
XOT09200PC











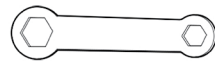

Parts list

PART A

PART NO	STYLE PIC	QUANTITY			
1	133.5CM 	10	12	102.5CM 	1
2	153.5CM 	6	13	102.5CM 	1
3	84CM 	1	14	134CM 	1
4		2	15	134CM 	1
5		2	16	60.5CM 	1
6		2	17	84CM 	1
7	106.5CM 	4	18	85CM 	1
8		3	19		2
9	102.5CM 	7	20	72.5CM 	1
10		1	21	72.5CM 	1

XOT09200PC

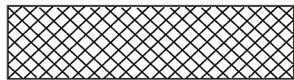
PART A

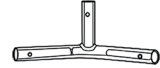

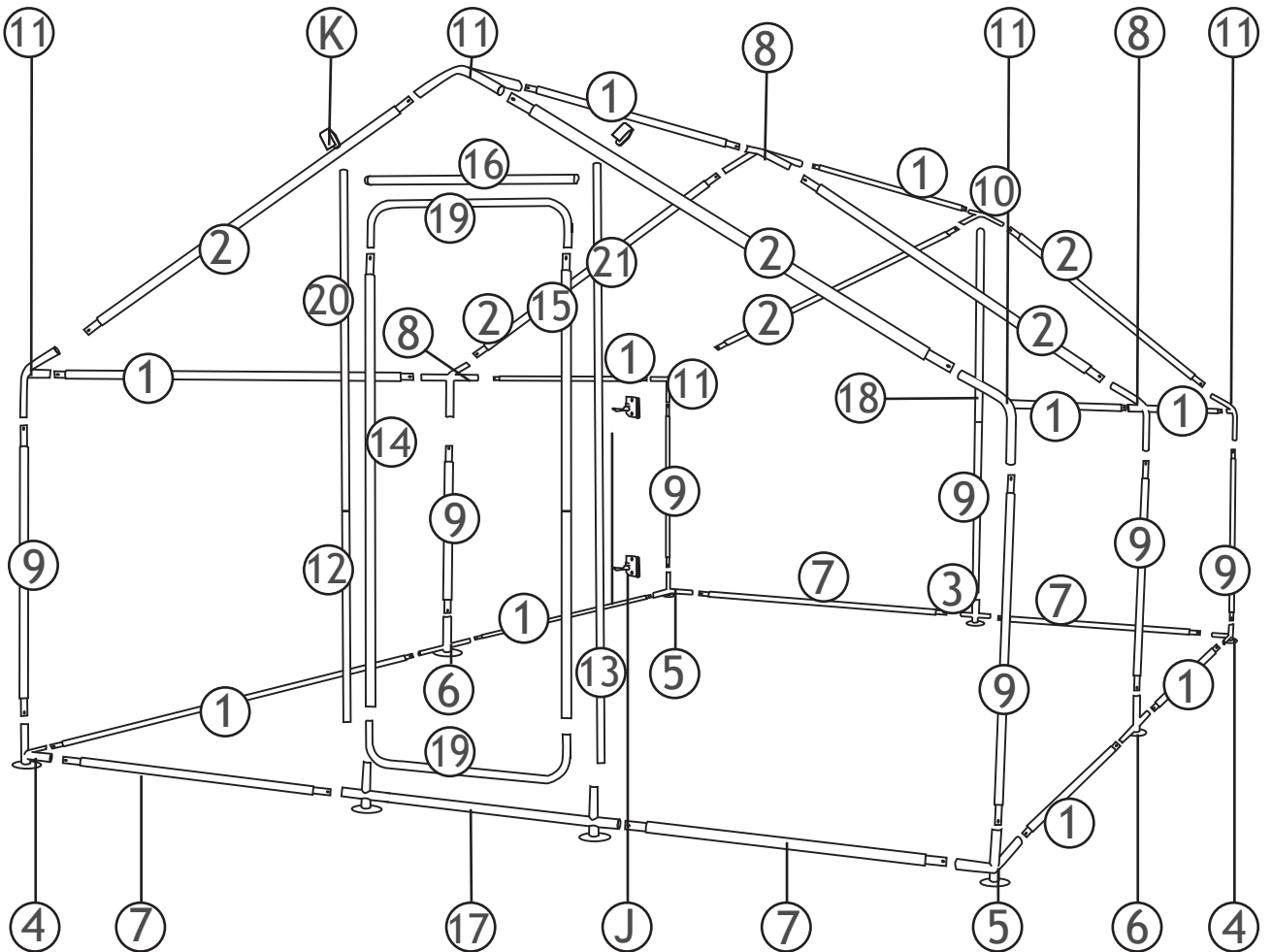

PART NO	STYLE PIC	QUANTITY			
J		2	O		1
K		2	P		16
L		2	Q		220
M2		2	R		2
M3		8	Rain Cover		1
N1		1	Big Mesh		1
N2		4	11		5



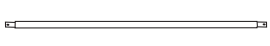
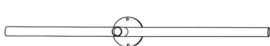

XOT09200PC

EN

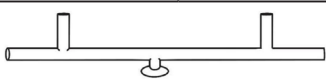
Assembly

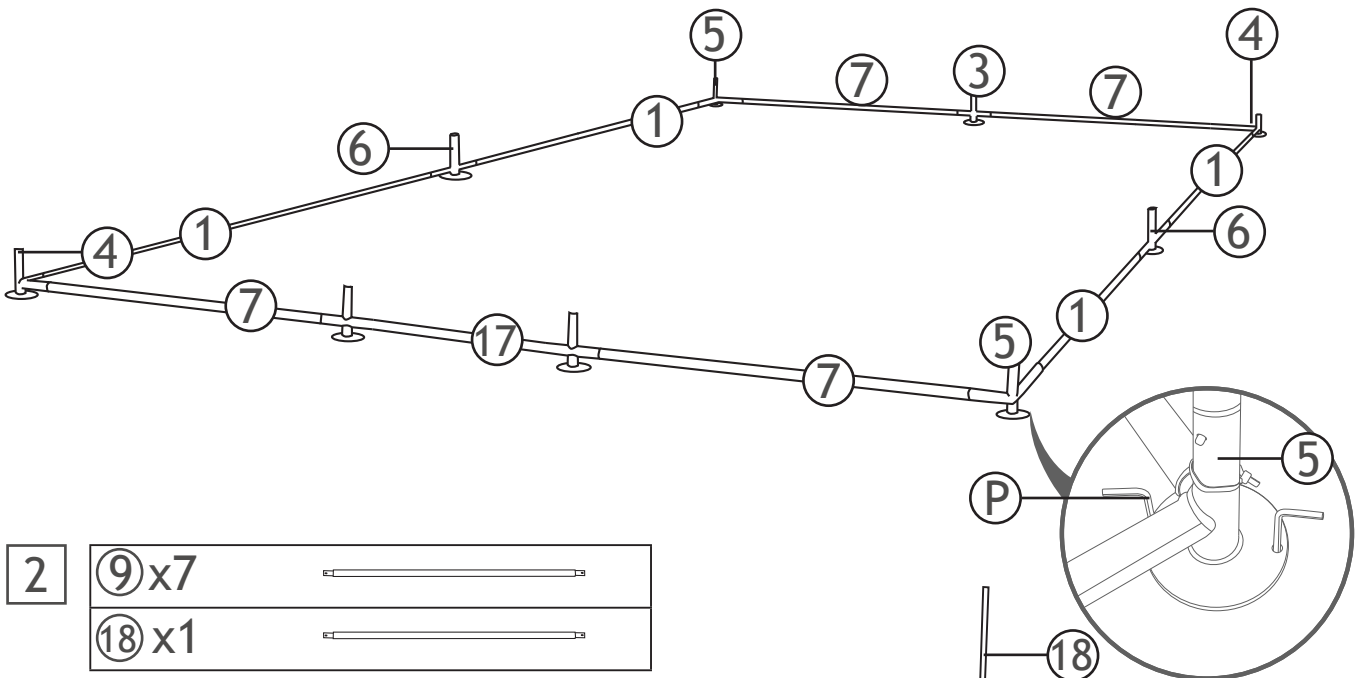
1	①x4		③x1		④x2	
	⑤x2		⑥x4		⑦x4	
	⑰x1					



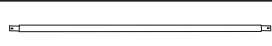

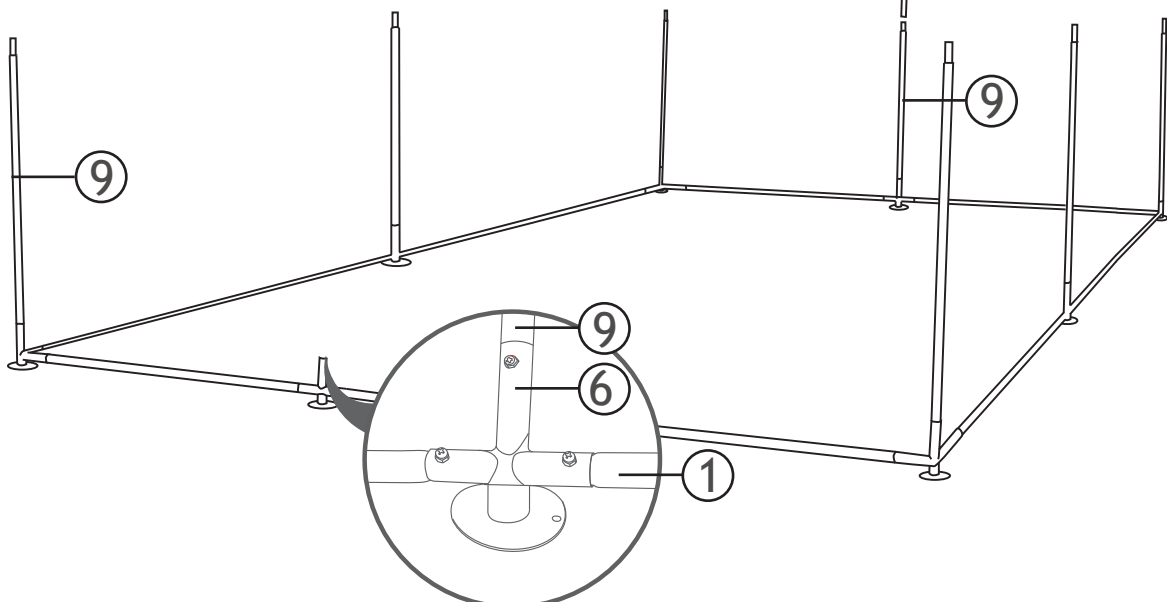

2	⑨x7	
	⑱x1	



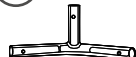

XOT09200PC

EN

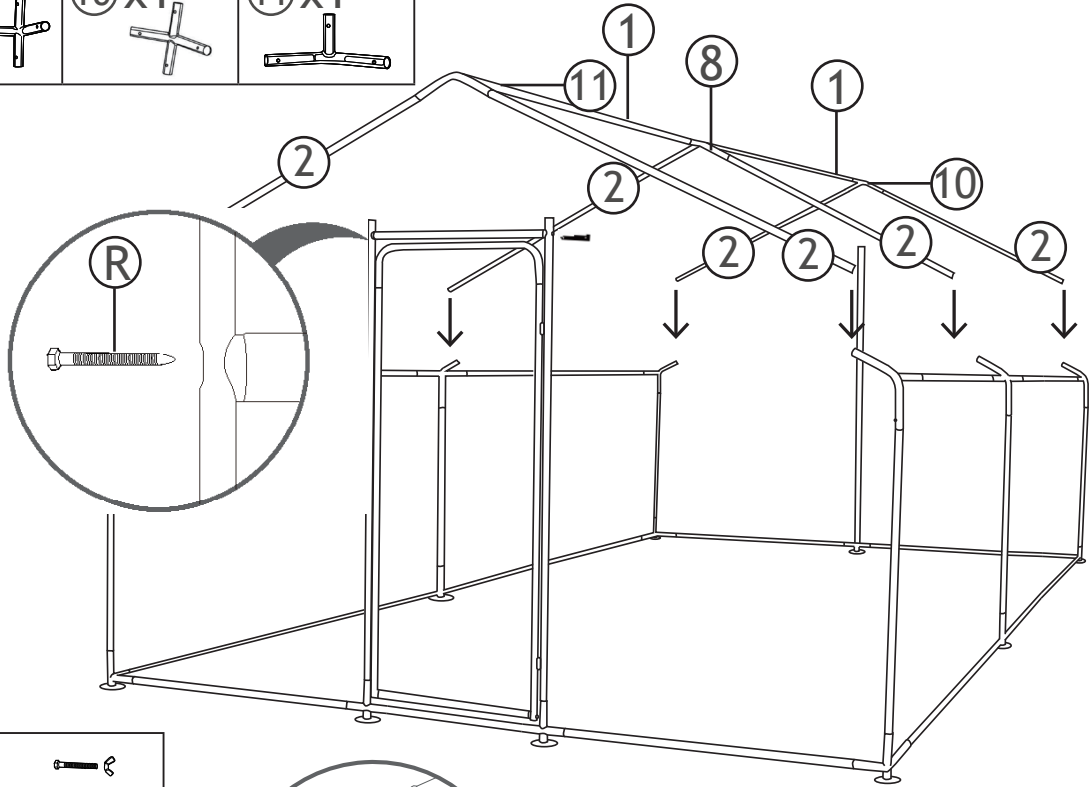
- 5
- | | |
|-----|---|
| ①x2 |  |
| ②x6 |  |
| ⑧x1 |  |
| ⑩x1 |  |
| ⑪x1 |  |



- 6
- | | |
|-------------------|---|
| M ₂ x2 |  |
| Kx2 |  |

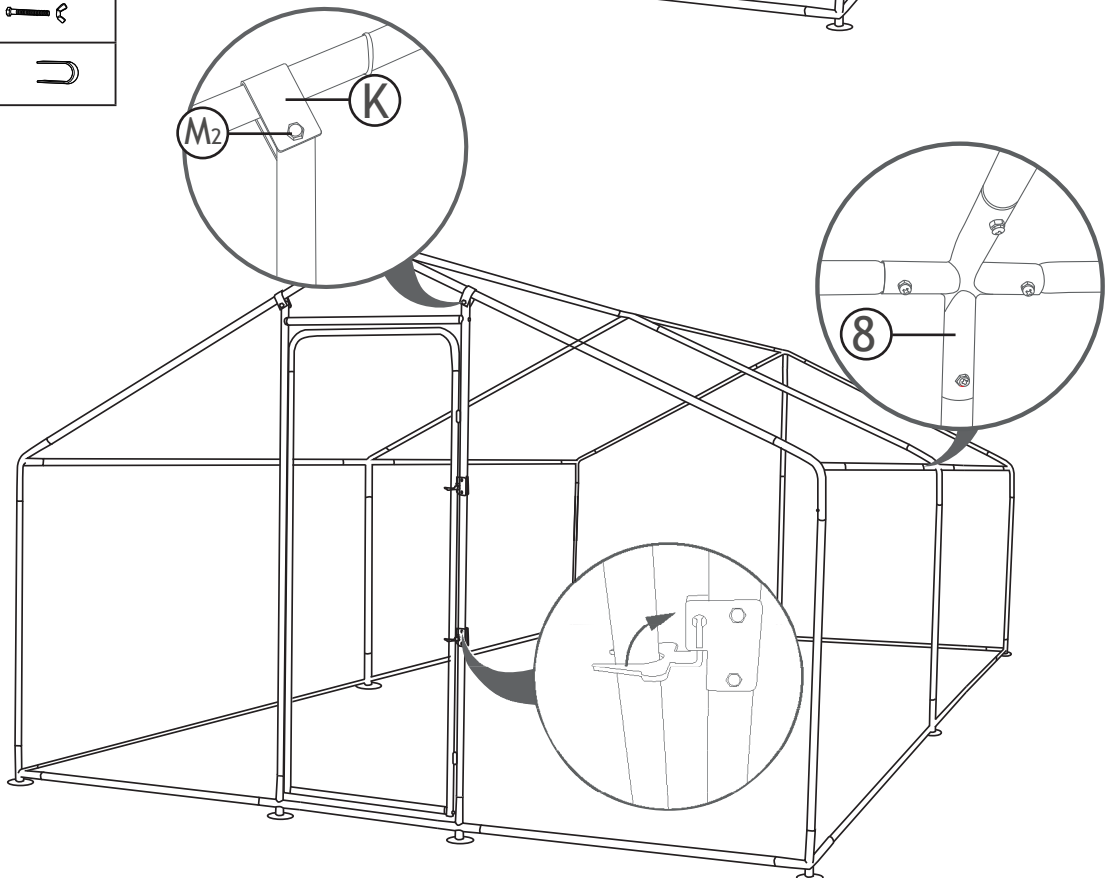

XOT09200PC

7 $\text{Q} \times 250$ 

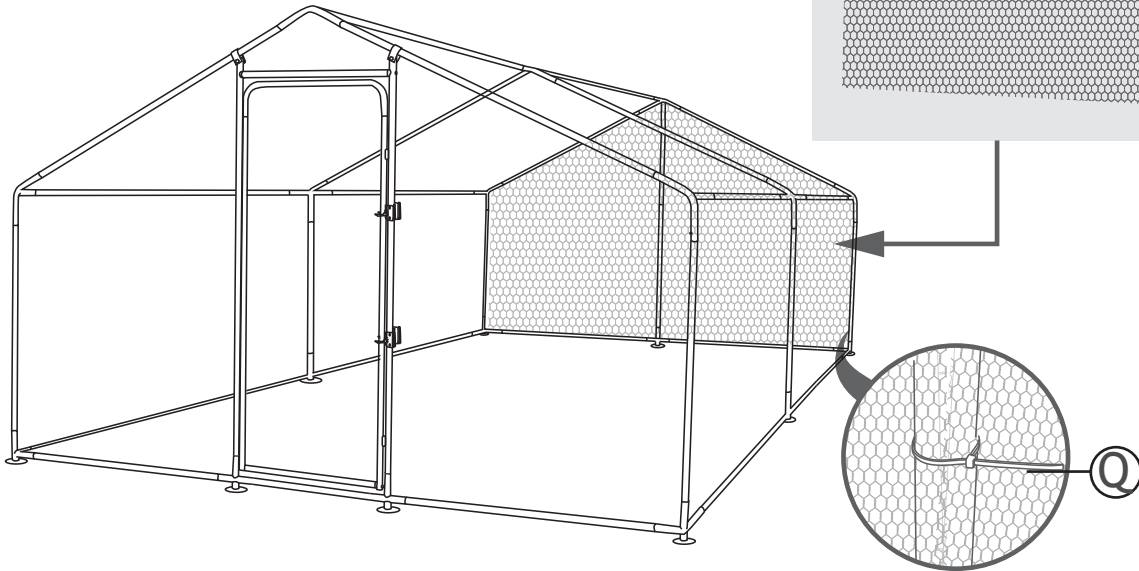

To cut 2 pieces of 9.85 ft mesh, install behind the chicken cage (opposite of the door). link and fix with straps.

8

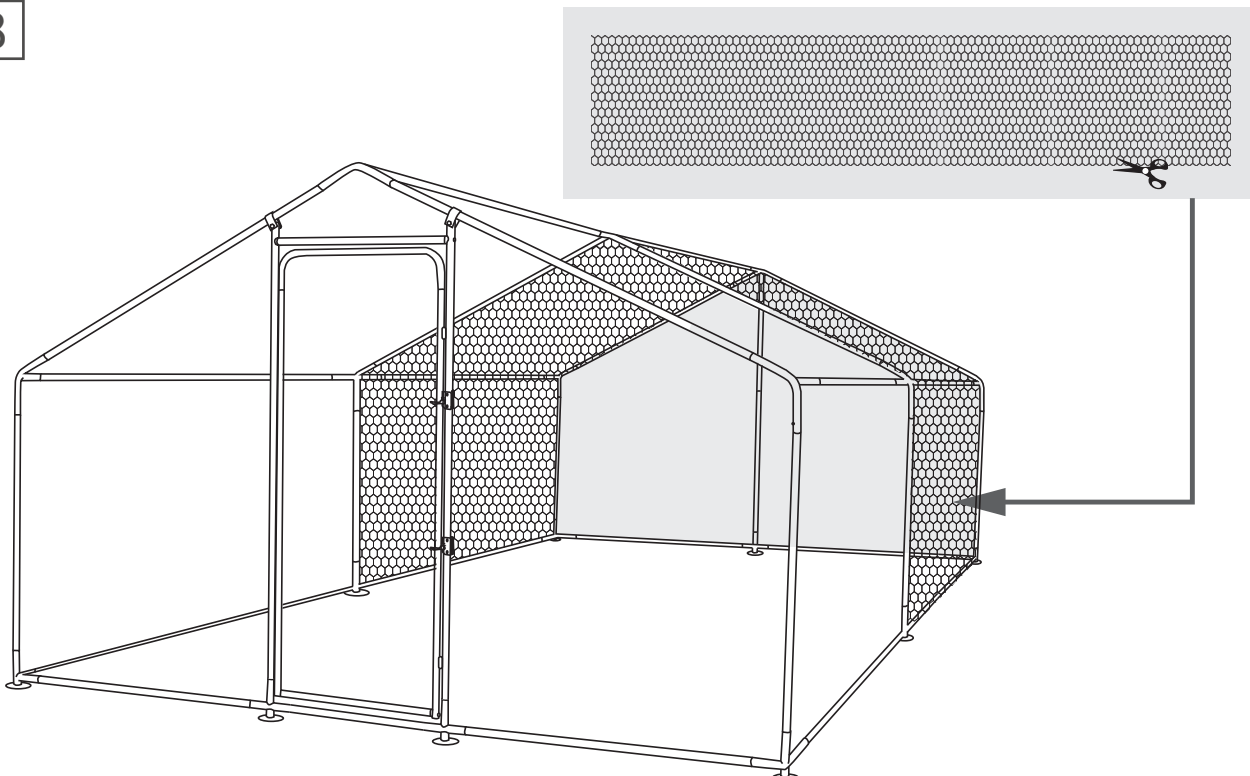

To cut 6 pieces of 18.9 ft mesh. When installing, extend from the top to the sides, link and fix with straps. After the 6 pieces are installed, the side and top are completed.

XOT09200PC

9

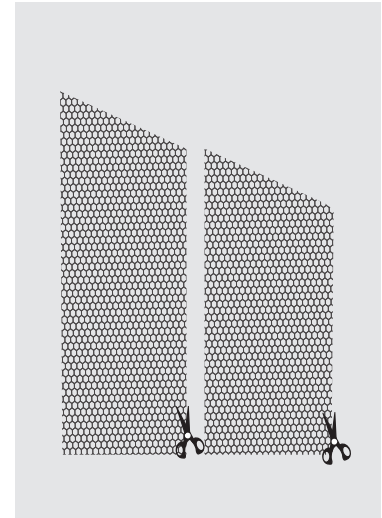
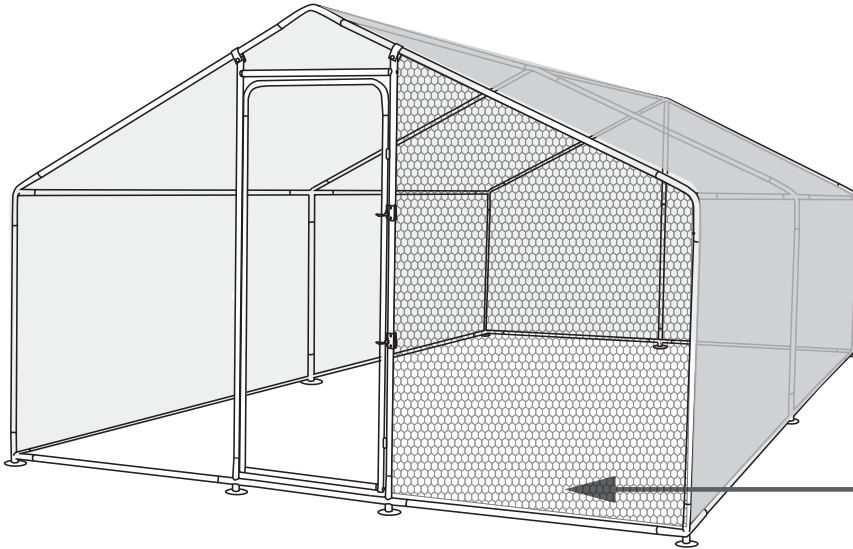

To cut 4.4 ft into piece of 1.64 ft wide, install on the left side of the front.
To cut 2 piece of 5.74 ft mesh, install on the both side of the door.

10

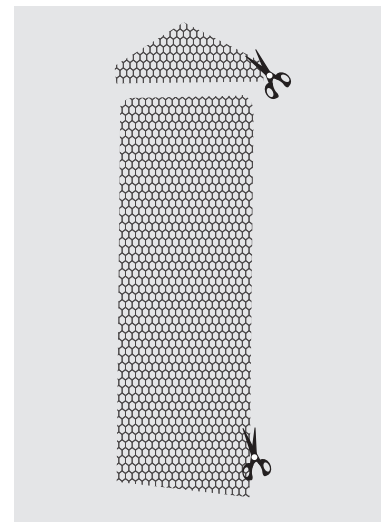
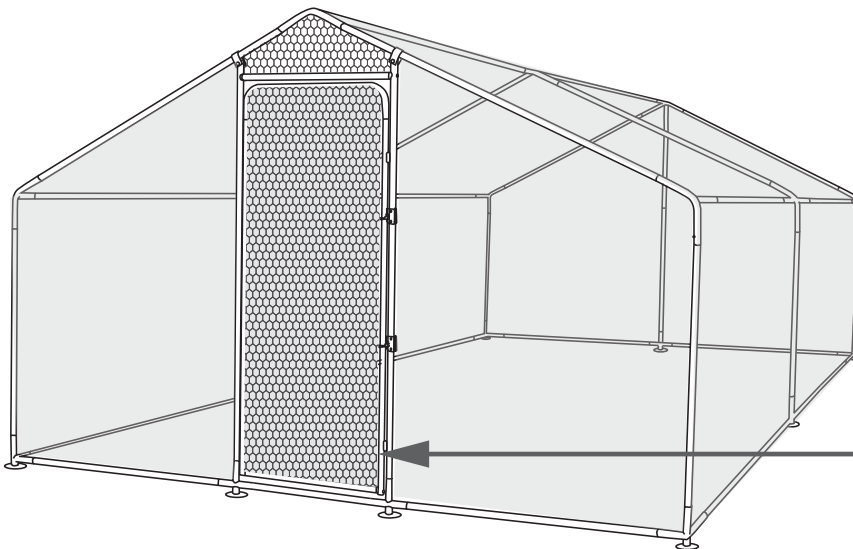

To cut 3.94 ft x 1.15 ft mesh, install above the door, fix with straps.complected.
To cut 1 piece of 7.05 ft mesh, install on the door frame and fix with straps.

XOT09200PC

11

