

Assembly Instructions

Caution: You must read this before you proceed

Chair

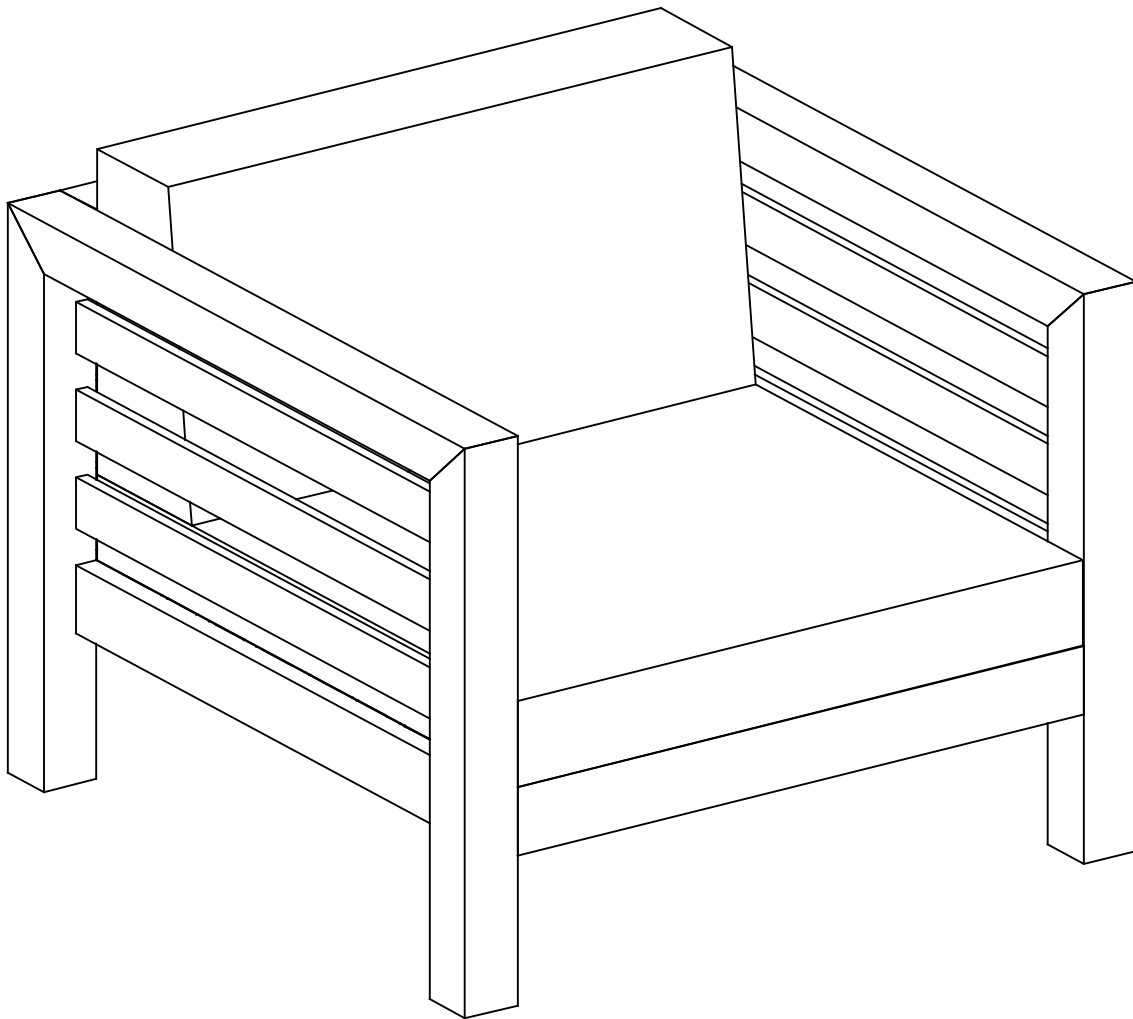

Caution: This Chair is NOT a TOY.



Keep your child/children at bay during the assembly process.

Whenever lifting or moving the Chair and to prevent damage to the Chair, two adults may be needed to execute these actions.

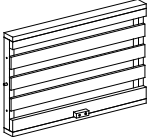
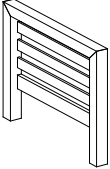
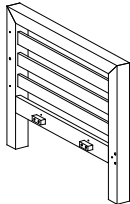
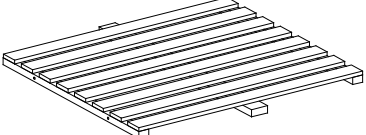
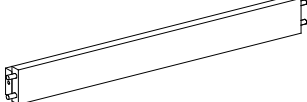
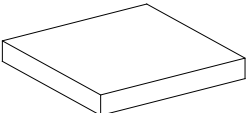
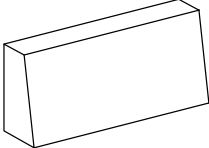
Part List

Label	Picture	Description	Qty
A		Backrest Panel	1
B		Left Arm Panel (with Pre-installed Levellers)	1
C		Right Arm Panel (with Pre-installed Levellers)	1
D		Seat Panel	1
E		Support Bar	1
F		Seat Cushion	1
G		Back Cushion	1

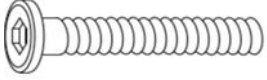



Hardware

No.	Picture	Description	Qty
①		Bolt (M6x35mm)	7
②		Screw (M6x45mm)	5
③		Allen Key	1

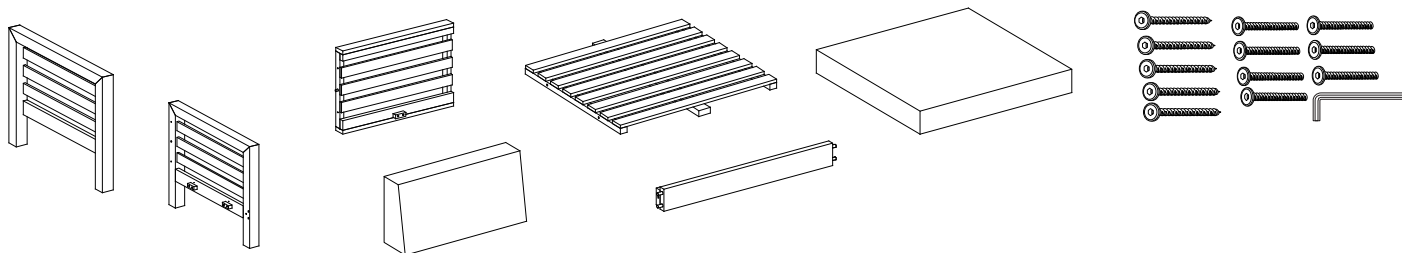
Assembly Preparation

Before Beginning Assembly:



-  • Read instructions, cover to cover-
-  • Have 2 adults on hand for assembly-
-  • Do not assemble on flooring or carpet-
-  • Assemble on a clean non-marring surface (packing foam)-
-  • Save all packaging until finished-

Assembly Steps

Overview

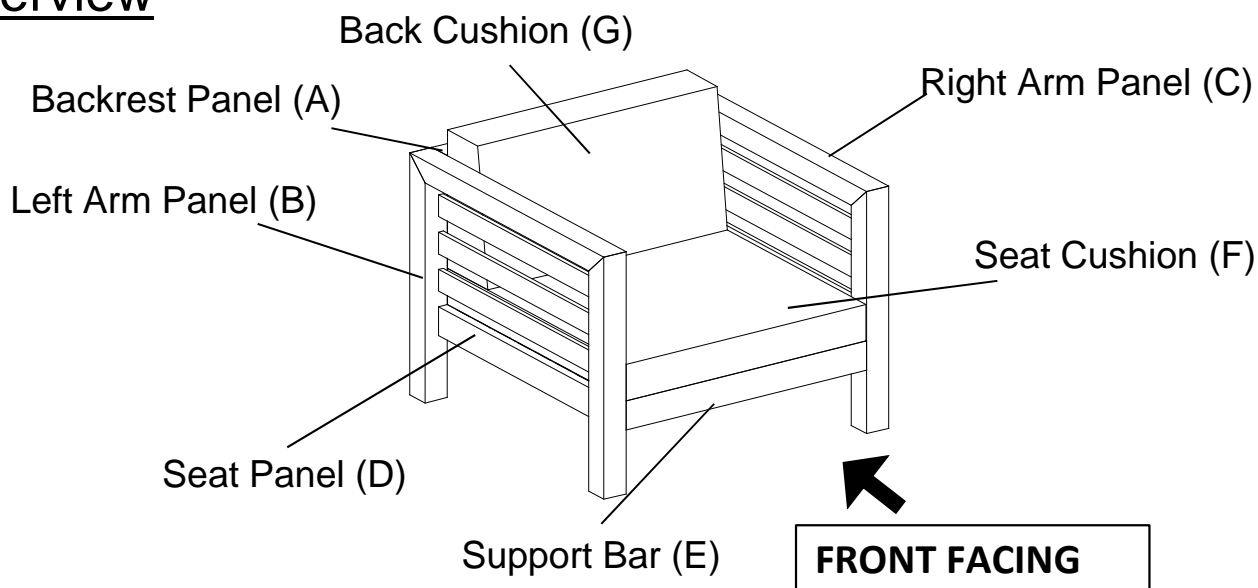

This Chair has multiple parts and may require up to 30 minutes to assemble. To give you an overview of the Chair parts, the above picture is to help you put the various parts into perspective. Please read through the instructions below to familiarise yourself with the parts and steps before assembly.

Step 1

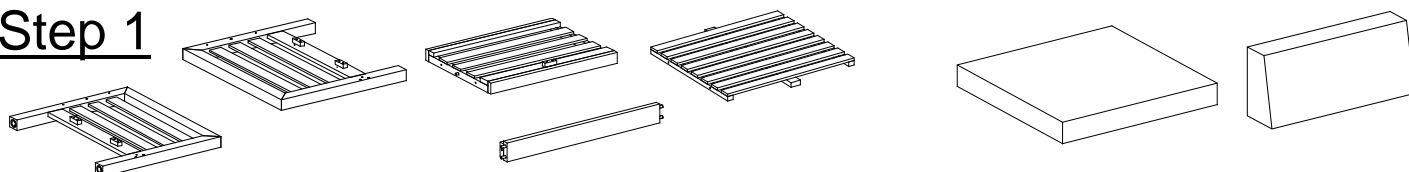

Unpack and place all parts on a clean, non-marring surface.

Step 2

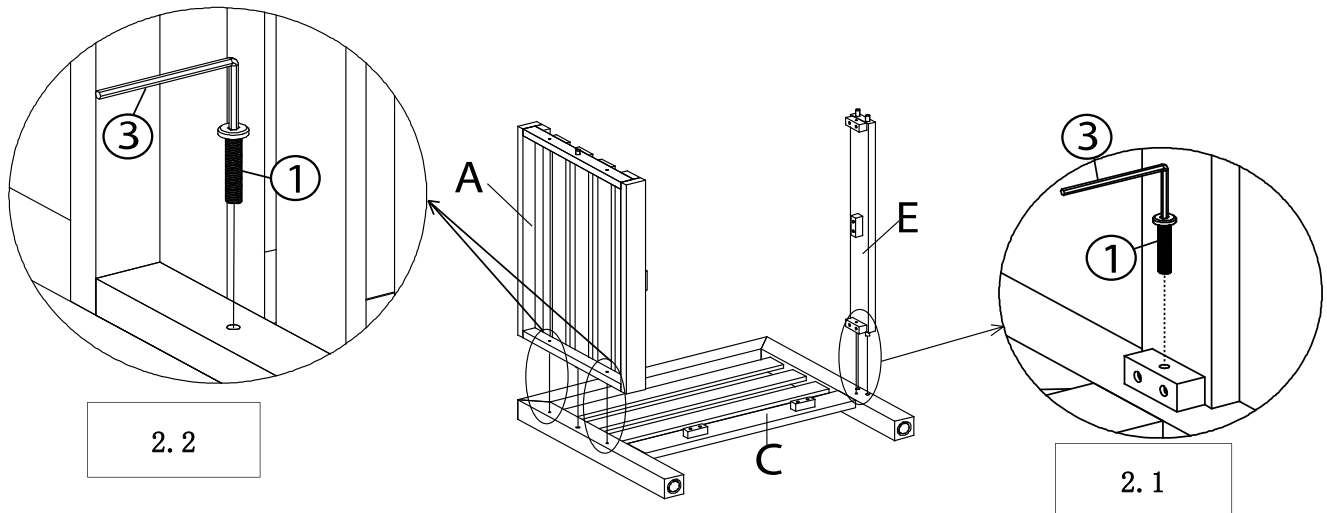

Place the Right Arm Panel(C) facedown onto a clean, non-marring surface.

- 2.1)** Insert the dowels of Support Bar(E) into the mountings in the Right Arm Panel(C). Attach Support Bar(E) to Right Arm Panel(C) using Bolt(①) with Allen Key(③).
- 2.2)** Attach Backrest Panel(A) to Right Arm Panel(C) using Bolts(①) with Allen Key(③).
Do not fully tighten the Bolts.

Step 3

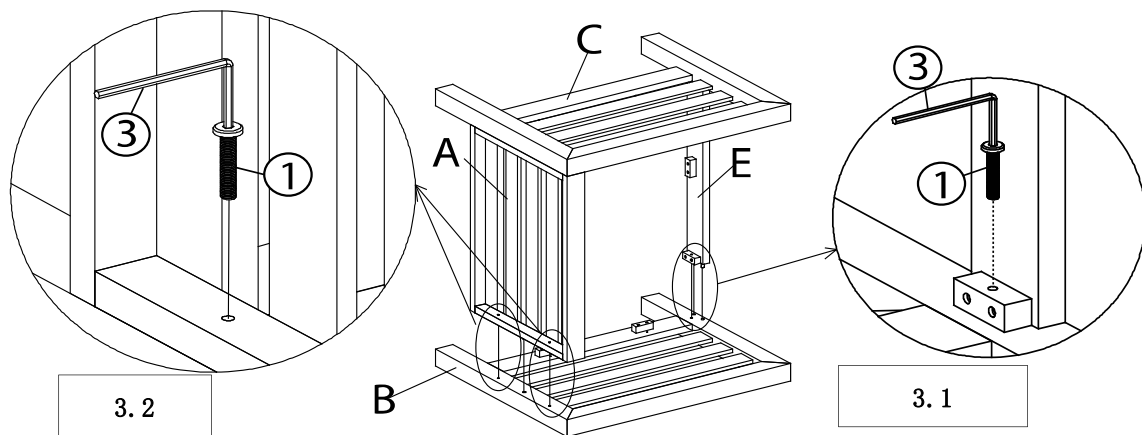

Place the Left Arm Panel(B) facedown onto a clean, non-marring surface.

- 3.1)** Insert the dowels of Support Bar(E) into the mountings in the Left Arm Panel(B). Attach Support Bar(E) to Left Arm Panel(B) using Bolt(①) with Allen Key(③).
- 3.2)** Attach Backrest Panel(A) to Left Arm Panel(B) using Bolts(①) with Allen Key(③).
Do not fully tighten the Bolts.

Step 4

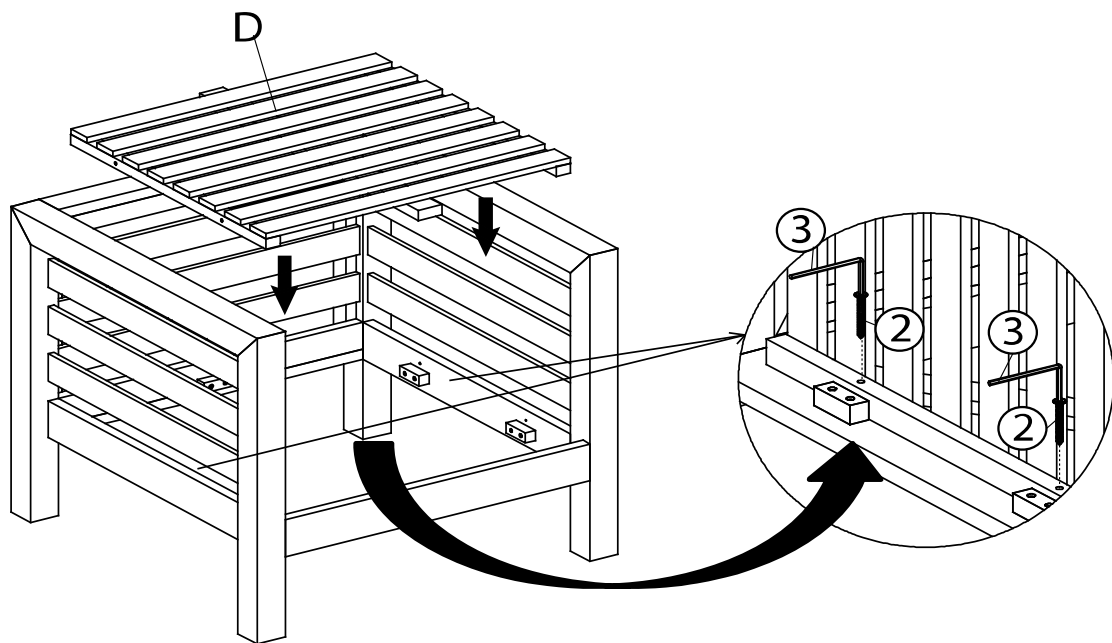

Attach Seat Panel(D) to the Chair using Screws(②) and Allen Key(③).

Note: Insert Screws(②) from inside to outside of Seat Panel(D).

Do not fully tighten the Screws.

Step 5

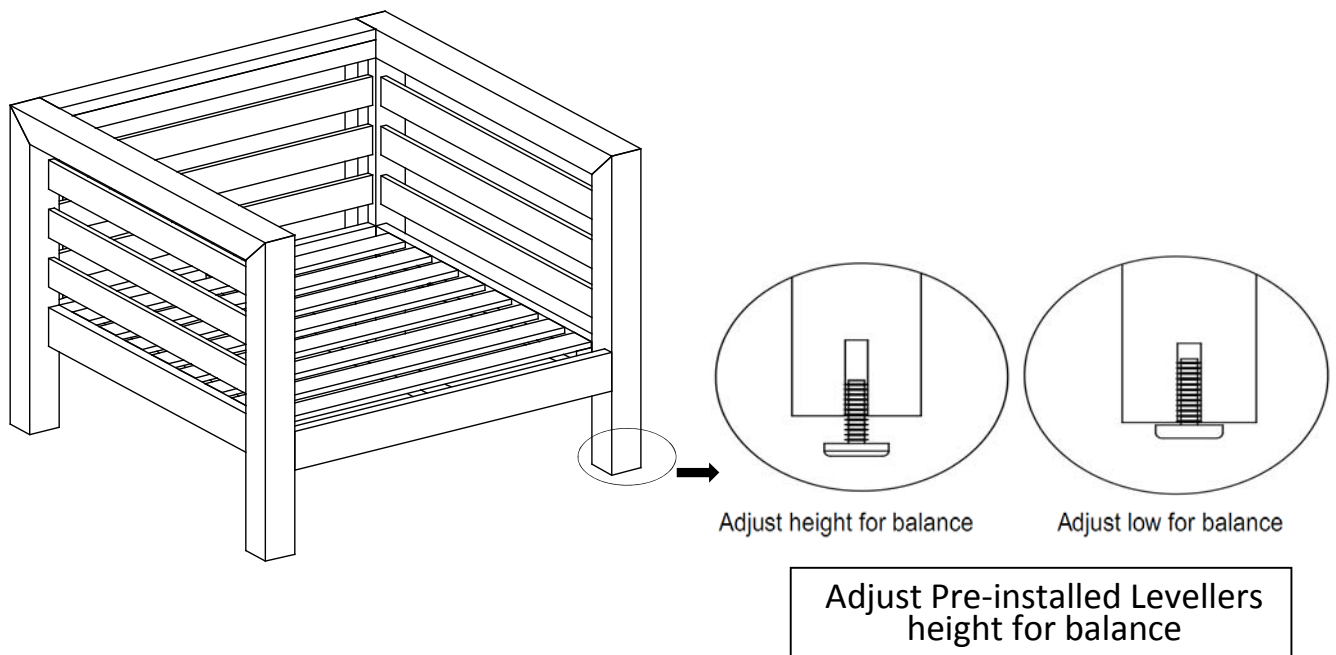

Inspect the Chair and make sure all parts are adequately connected.

Carefully sit onto the Chair. This pressure will help align all parts at all joints.

In a sequential manner, tighten all Bolts and Screws at all joints.

Adjust the Levellers until the Chair is level with the ground.

To adjust the Levellers, get assistance from an adult partner to lift/lean and hold the Chair while you are working.

Step 6

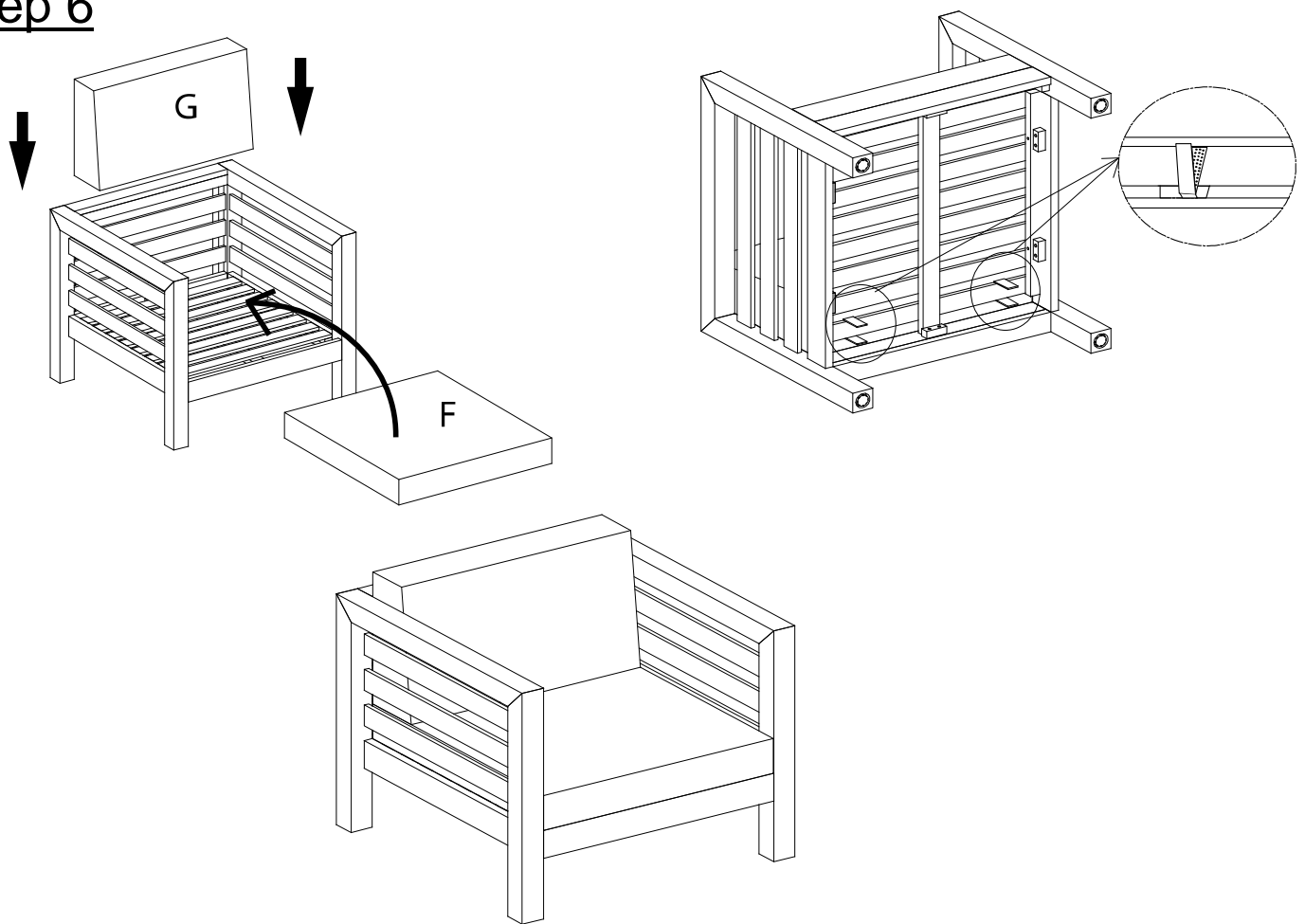





















Place Seat Cushion(F), and Back Cushion(G) onto the Chair, and affix the velcro straps around the Chair as shown above.

Your Chair is ready to be used.

This Chair can only be used on a flat, level surface.

Care & Maintenance

-   ● Do not put hot items directly on furniture surface
 -   ● Do not clean furniture with harsh cleansers or polish.
 -   ● To obtain the longest lifespan of your outdoor products, minimizing exposure to direct sunlight is recommended.
 -   ● Children should not climb or jump on the furniture.
 -   ● Do not write on furniture without a padded barrier to protect the surface.
 -   ● To obtain the longest lifespan of your outdoor products, avoid extended and lengthy exposure to rain, snow, and direct sunshine. Whenever possible cover the product and /or place under patio or awnings.
 -   ● Not for commercial use. For residential use only .
 -   ● Stains may be removed with mild soap solution and damp cloth.
 -   ● Keep away from sources of ignition.
-
-   ● Dust and pick-up spills using a clean, non-colored, lint-free cloth.