

Pegboard

# Accessory Package

**PLEASE NOTE:** Check that you have received all components and hardware before assembling. If you are missing any parts, please contact us for replacement parts.

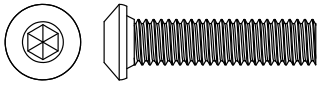

**A.** 1" Small Machine Screw - 12

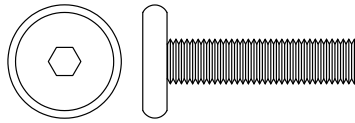

**B.** 1" Small Machine Screw - 4

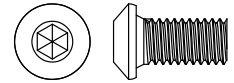

**C.** 1/2" Small Machine Screw - 2

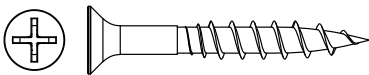

**D.** 1-1/2" Flat Head Screw - 12

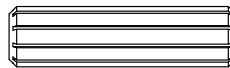

**E.** Wood Dowel - 8



**F.** 1/2" Flat Head Screw - 12

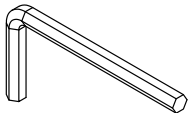

**G.** Wrench - 1

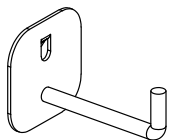

**H.** Short Hooks - 1

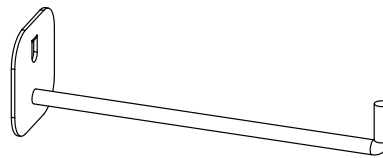

**I.** Long Hooks - 1

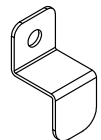

**J.** Bracket - 12

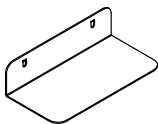

**K.** Shelf - 1

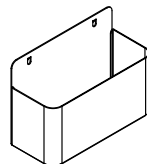

**M.** Box - 1

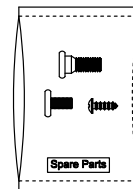

**L.** Spare Parts - 1

# Diagram of Components 1

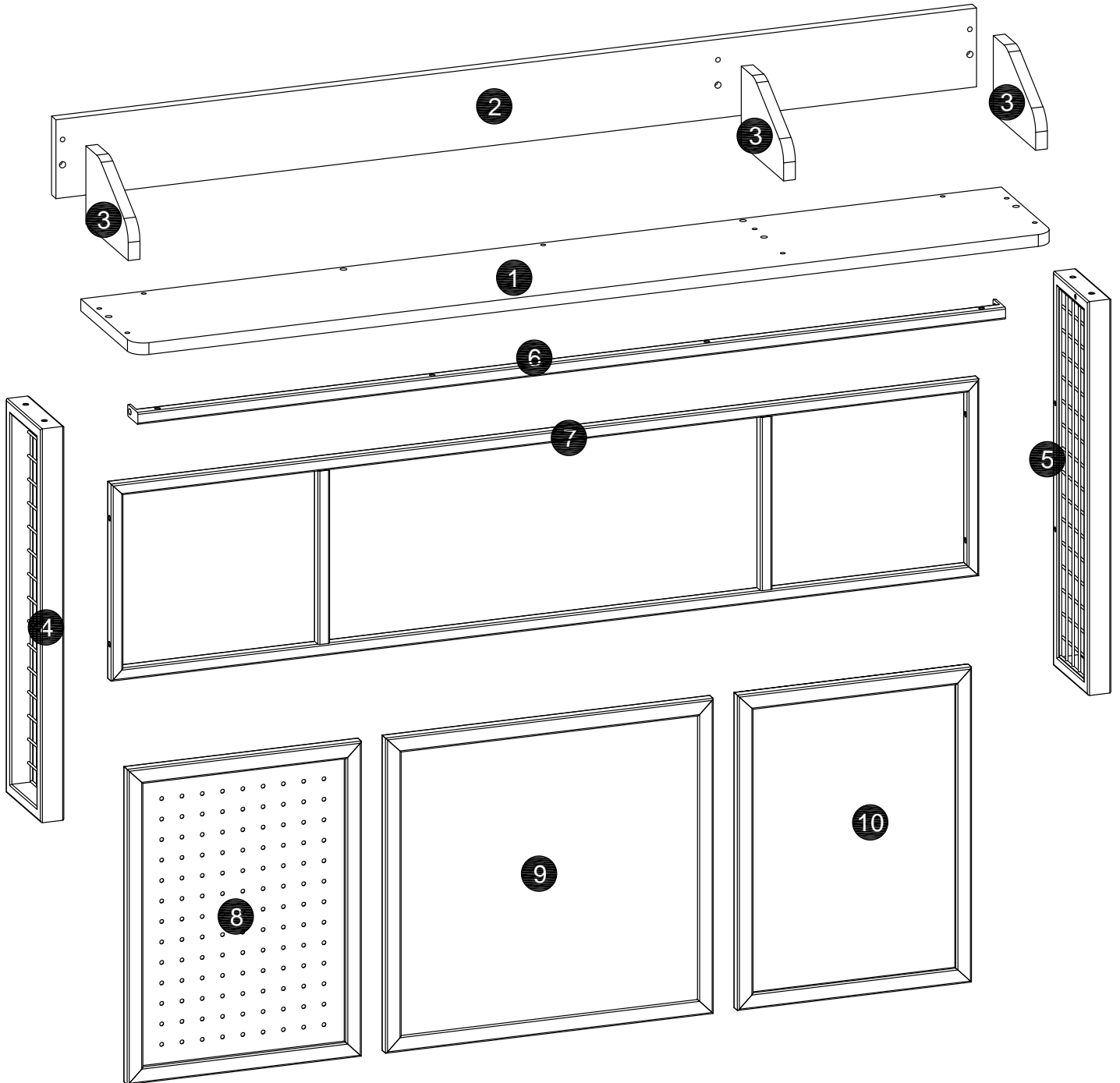

# STEP 1

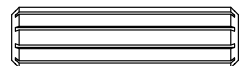
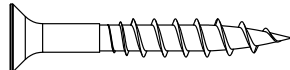
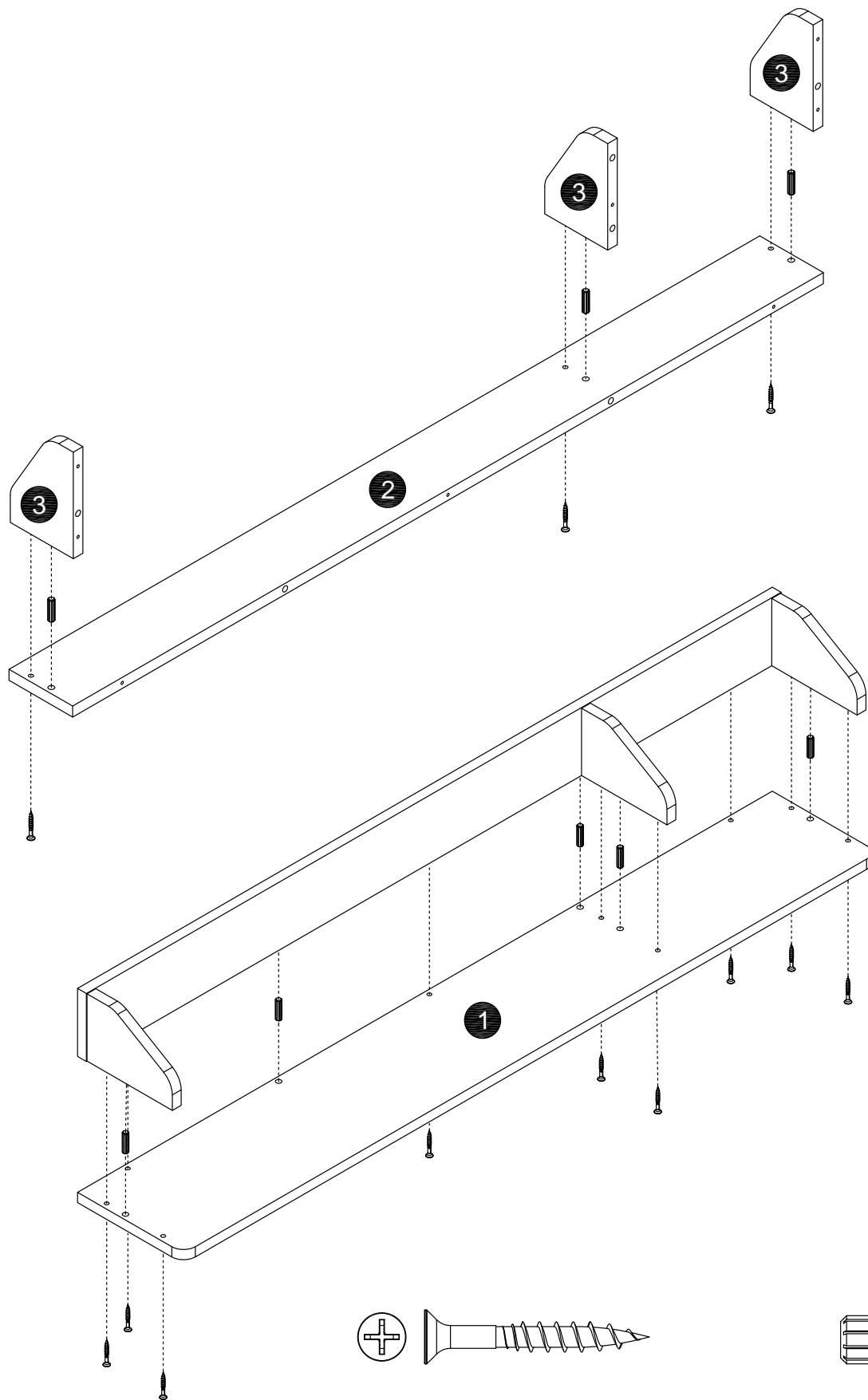

**D.** 1-1/2" Flat Head Screw - 12

**E.** Wood Dowel - 8

# STEP 2

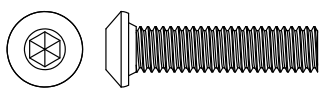
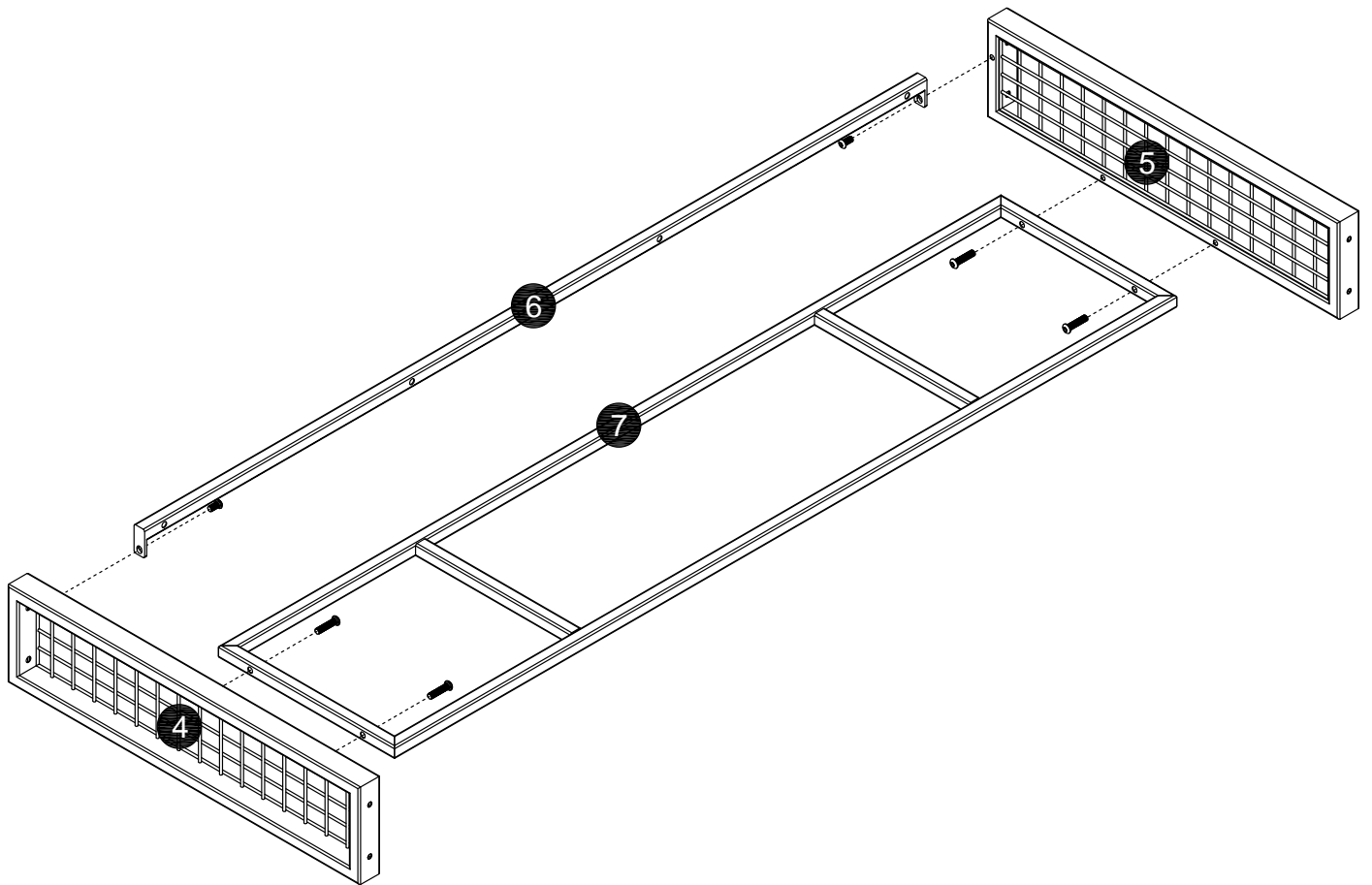

**A.** 1" Small Machine Screw - 4

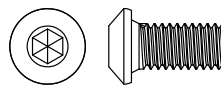

**C.** 1/2" Small Machine Screw - 2

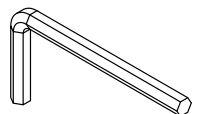

**G.** Wrench - 1

# STEP 3

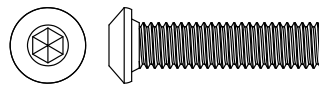
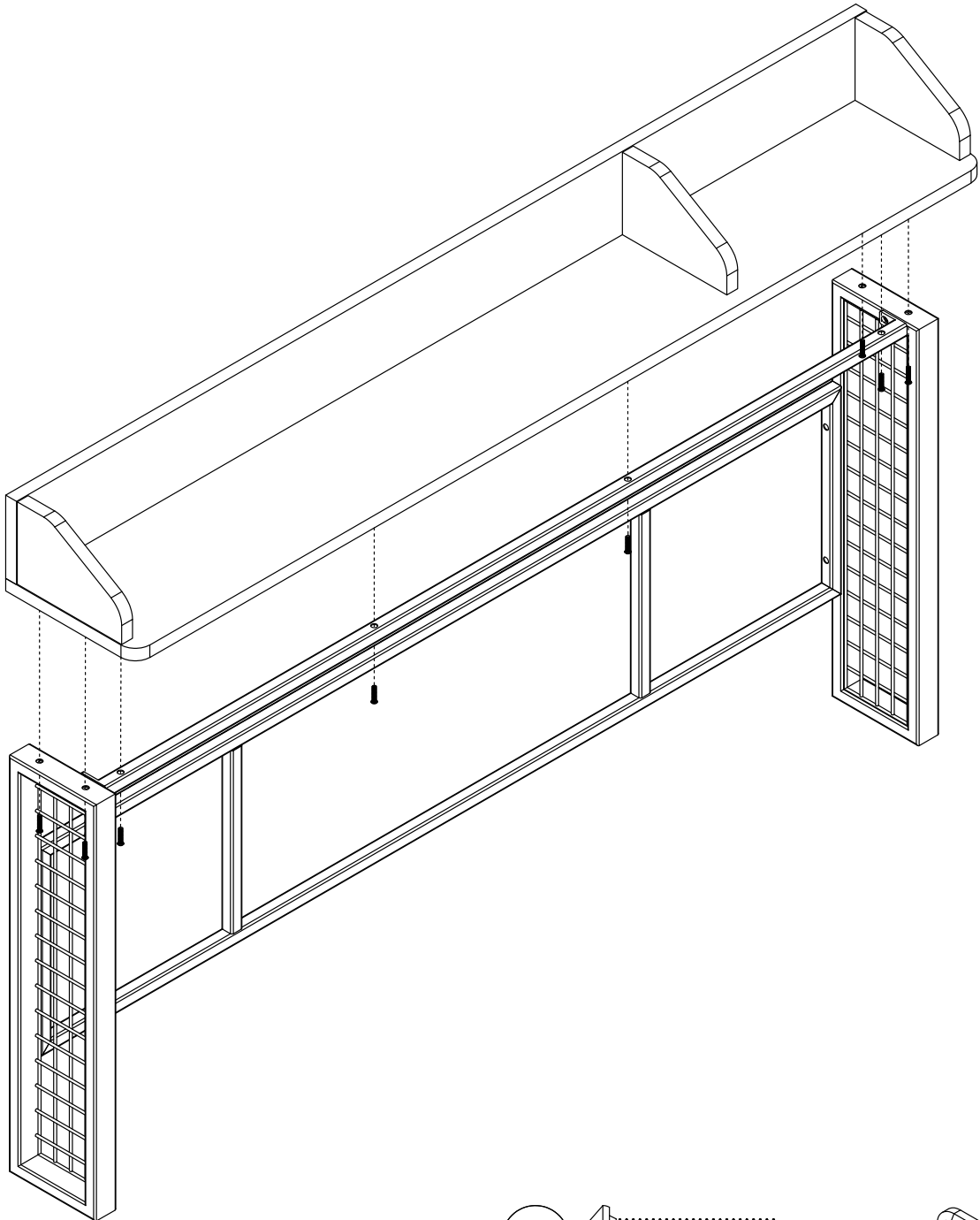

**A.** 1" Small Machine Screw - 8

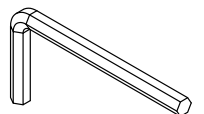

**G.** Wrench - 1

# STEP 4

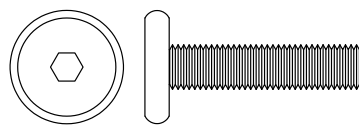
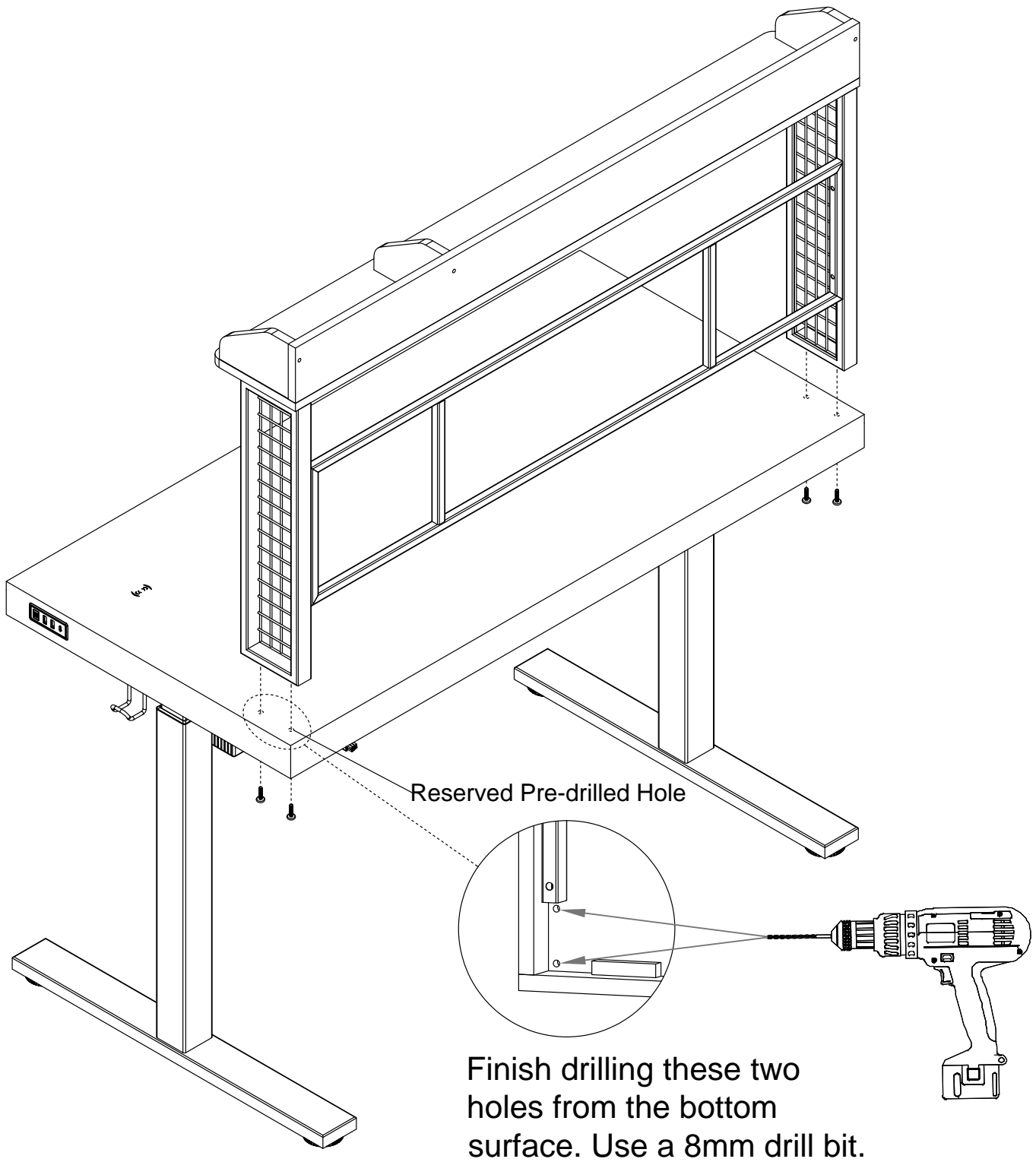

**B.** 1" Small Machine Screw - 4

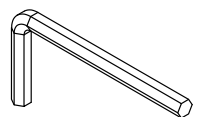

**G.** Wrench - 1

# STEP 5

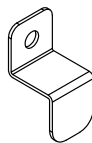
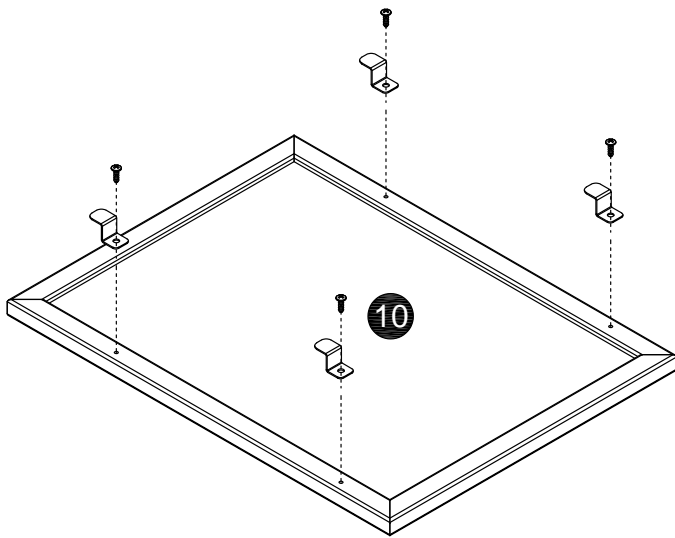
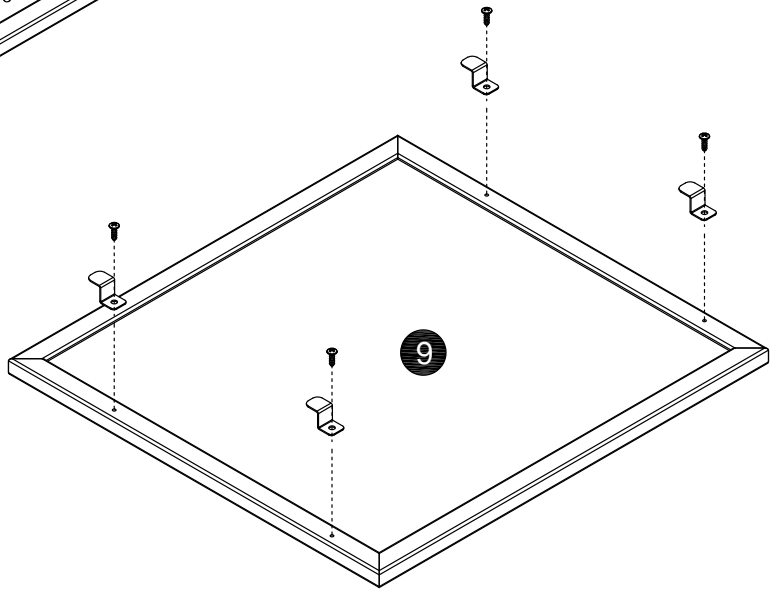
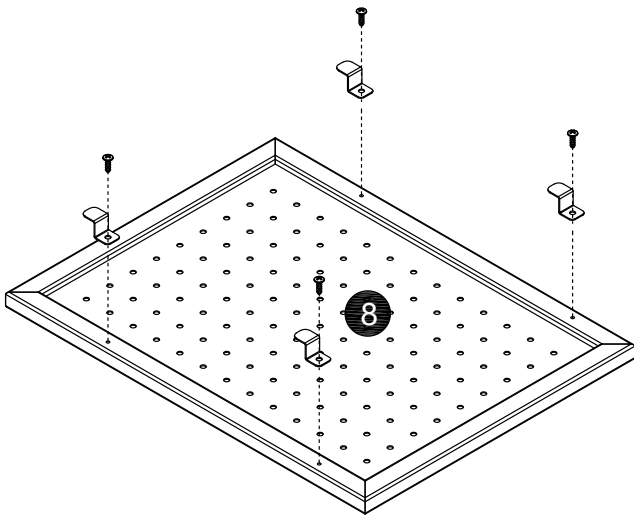

**J**.Bracket - 12

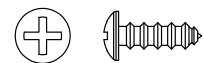

**F**.1/2"Flat Head Screw- 12

# STEP 6

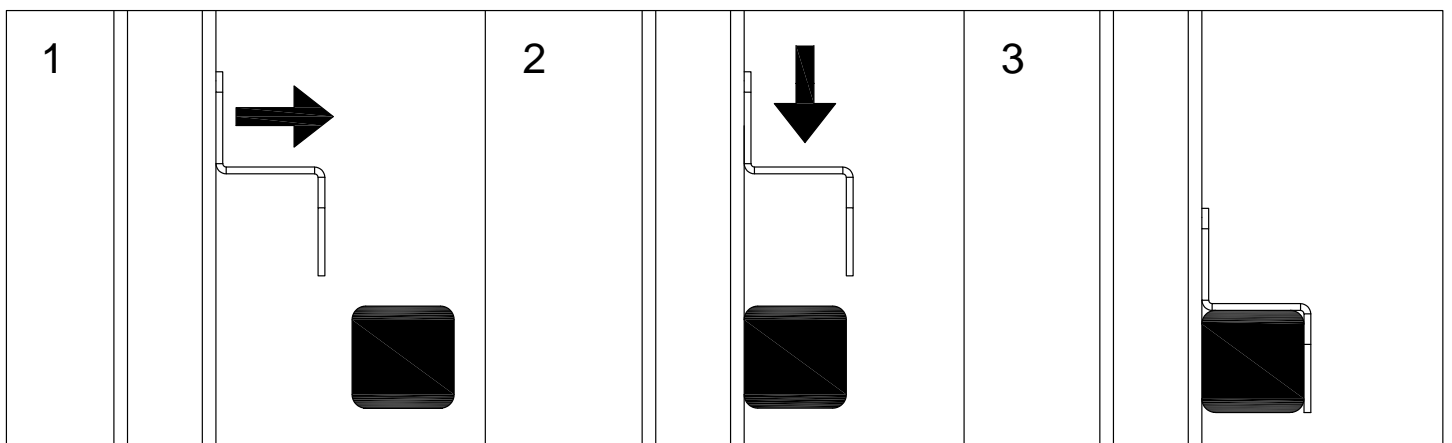
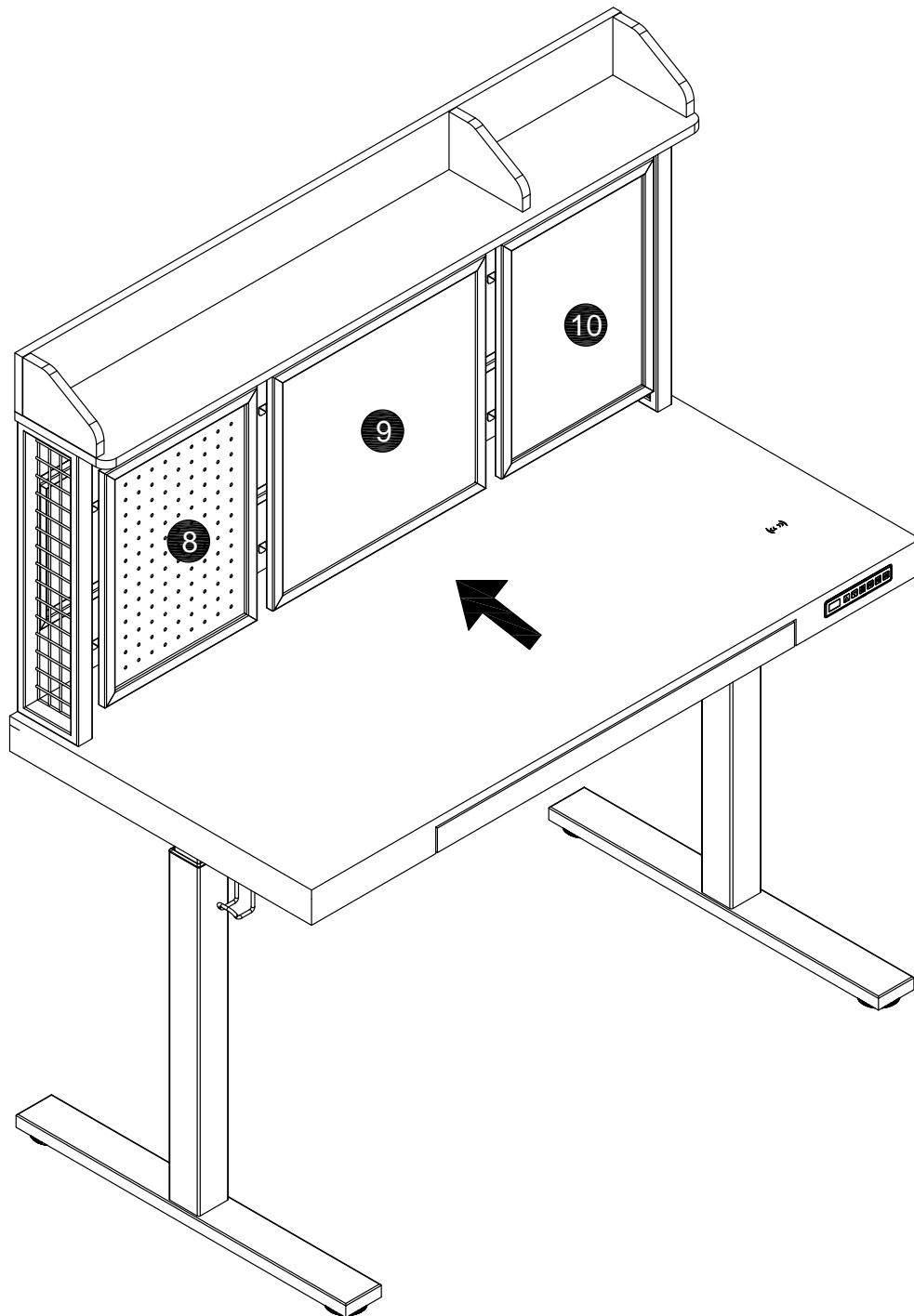

# STEP 7

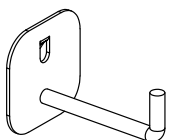
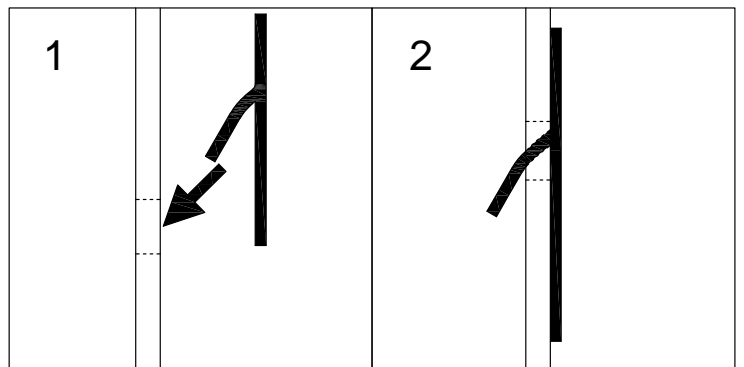
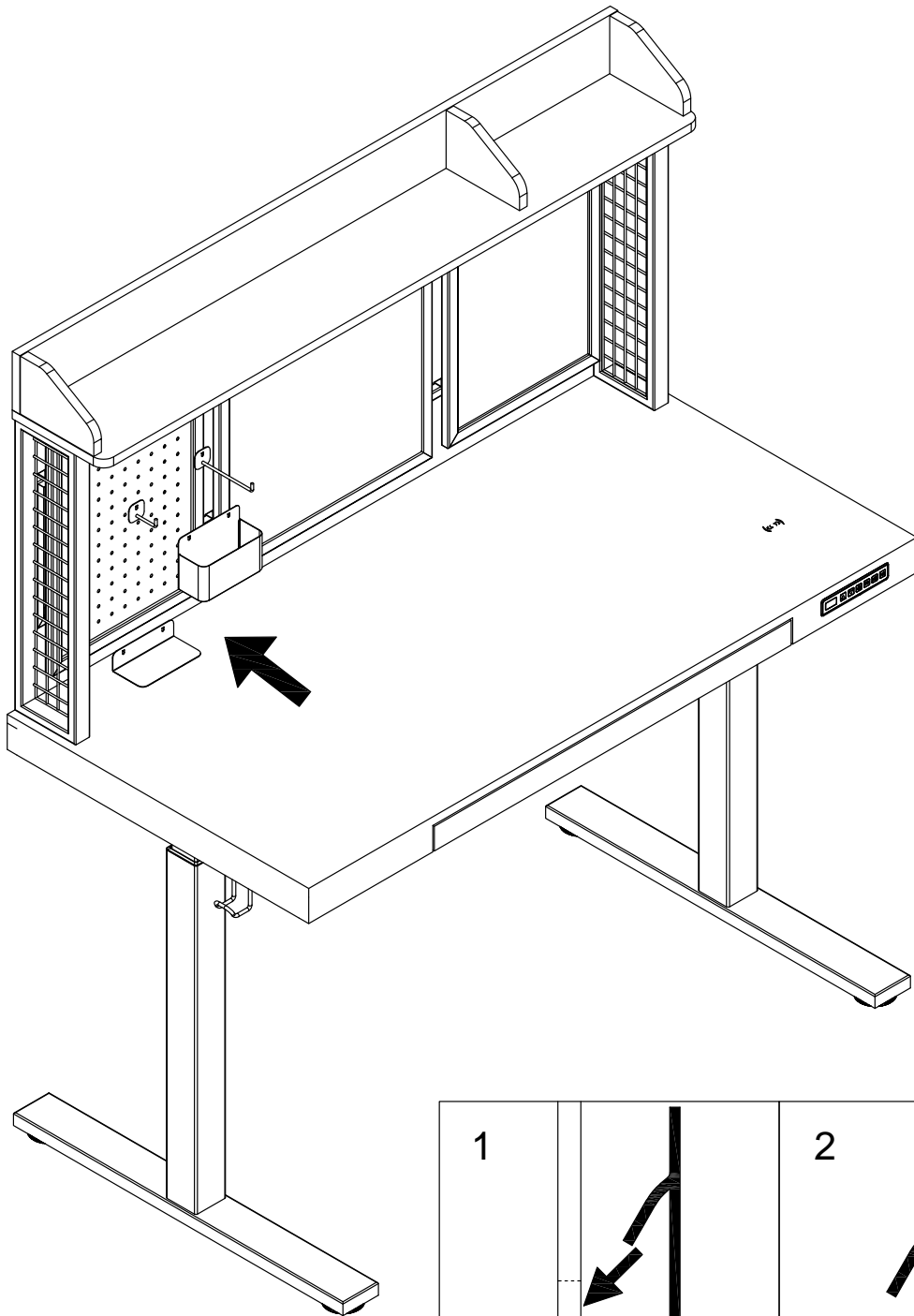

**H.** Short Hooks - 1

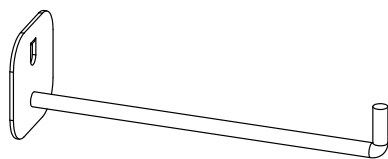

**I.** Long Hooks - 1

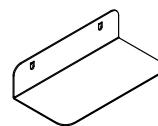

**K.** Shelf - 1

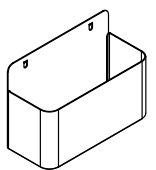

**M.** Box - 1

# STEP 8

