

ASSEMBLY INSTRUCTIONS
Nica End Table in White and Brown
ITEM #:T-10630-5-ET

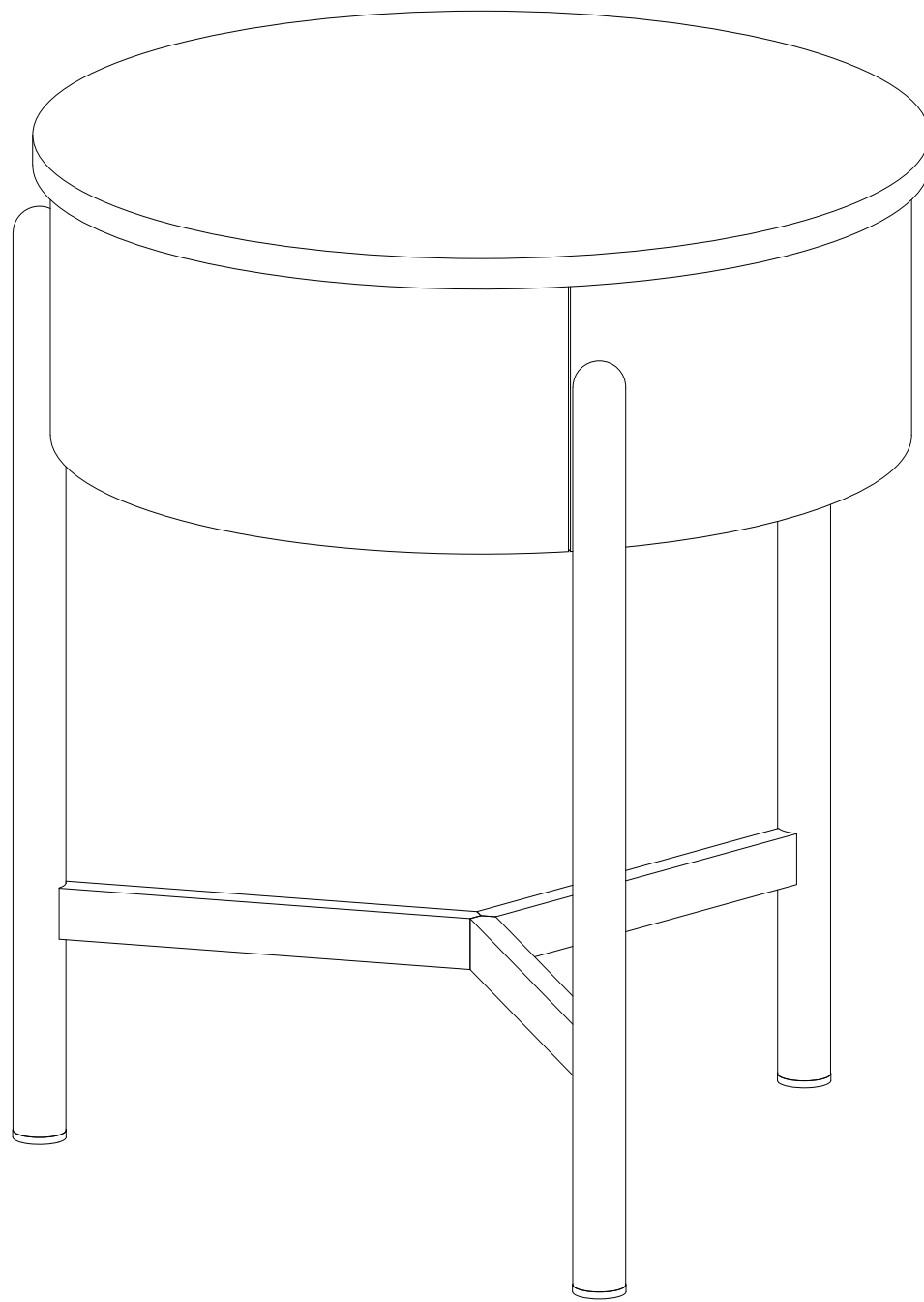



ASSEMBLY INSTRUCTIONS

Item #:T-10630-5-ET

Please identify and locate all assembly parts (see parts list) before discarding any packing materials.

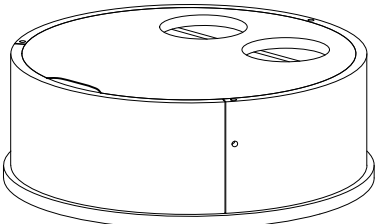
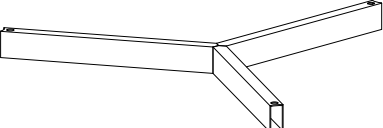
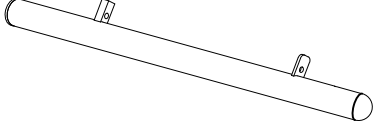
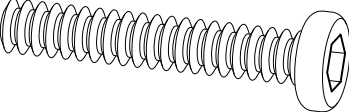
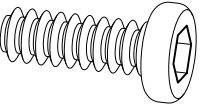
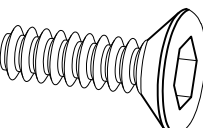
Some parts may have become loose during transit.

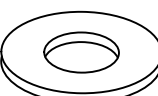
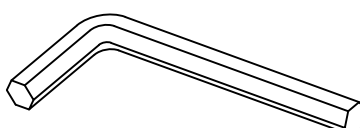
| PARTS LIST | | | |
|------------|---|-------------------------|------|
| NO. | SKETCH | DESCRIPTION | QTY |
| 1 |  | TOP BOX | 1PC |
| 2 |  | STRETCHER | 1PC |
| 3 |  | LEG | 3PCS |
| 4 |  | LONG BOLT 1/4"*40mm | 3PCS |
| 5 |  | SHORT BOLT 1/4"*19mm | 3PCS |
| 6 |  | SHORT BOLT 1/4"*12mm | 3PCS |
| 7 |  | LOCK WASHER 10mm | 6PCS |
| 8 |  | FLAT WASHER 16mm | 6PCS |
| 9 |  | ALLEN KEY 4mm | 1PC |

NOTE: Do not tighten until each step is completed or instructed.

Step 1:

1. Attach LEG(3) to TOP BOX (1) using Short Bolt (5) Lock Washer(7) and Flat Washer(8) as shown.
2. Insert Long Bolt (4) Lock Washer(7) Flat Washer(8) tighten with Allenkey(9) as shown.

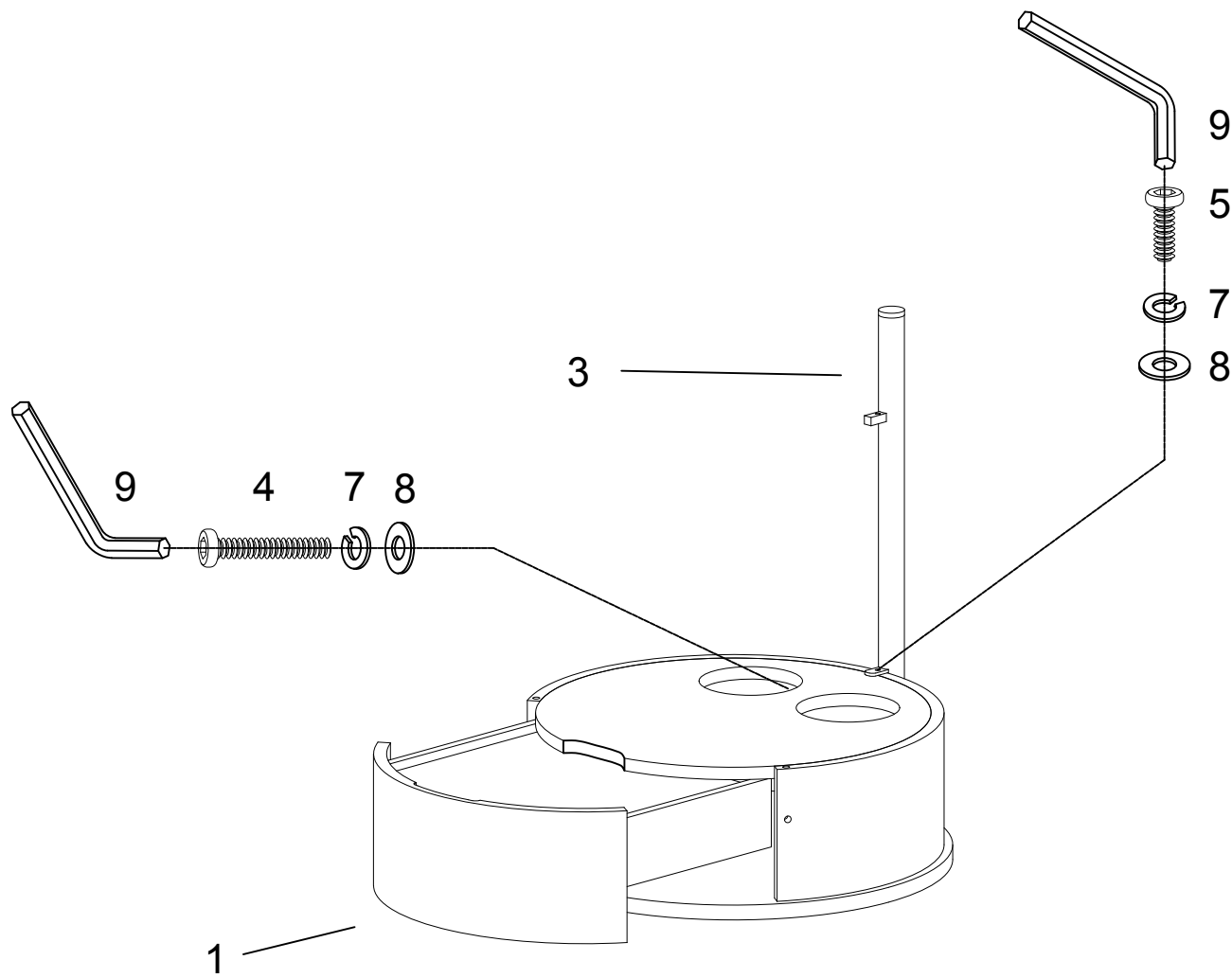

Step 2: Insert STRETCHER(2) into the assembled unit of Step1 using Short Bolt(6) tighten with AllenKey (9).

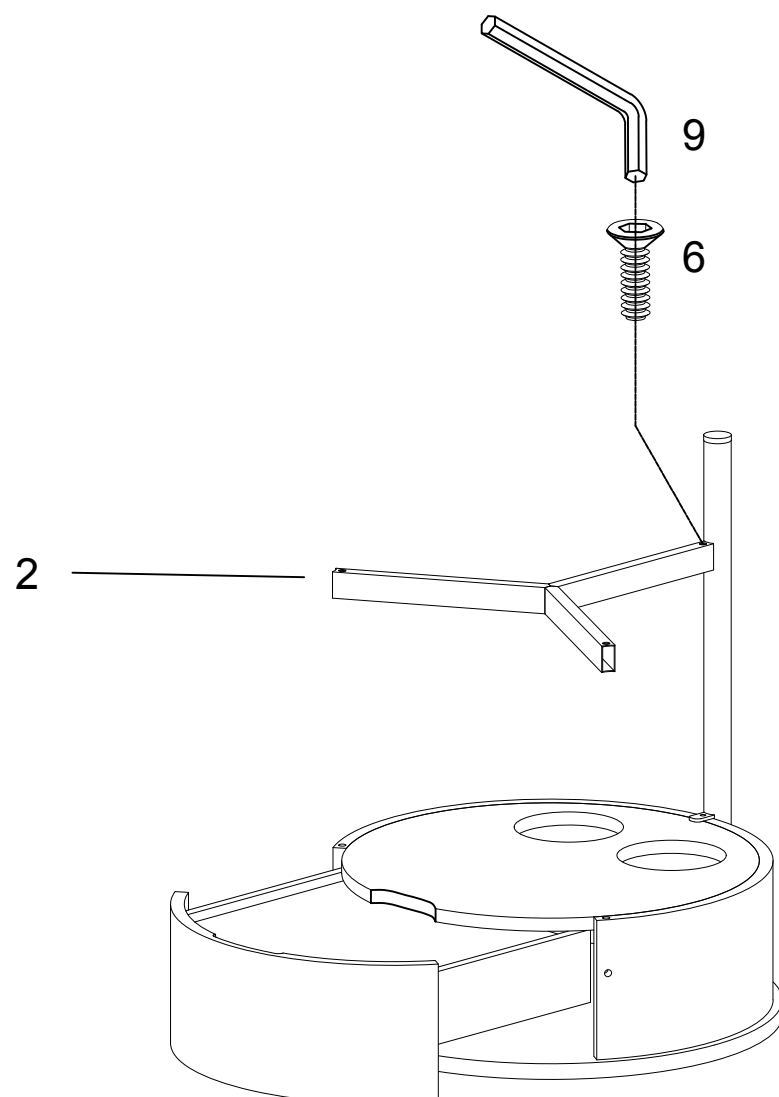

Step 3:

1. Attach the rest of the LEG (3) using Short Bolt (5) Lock Washer(7) and Flat Washer(8) as shown.
2. Insert Short Bolt (6) tighten with Allenkey(9) as shown.
3. Insert Long Bolt (4) Lock Washer(7) Flat Washer(8) tighten with Allenkey(9) as shown.

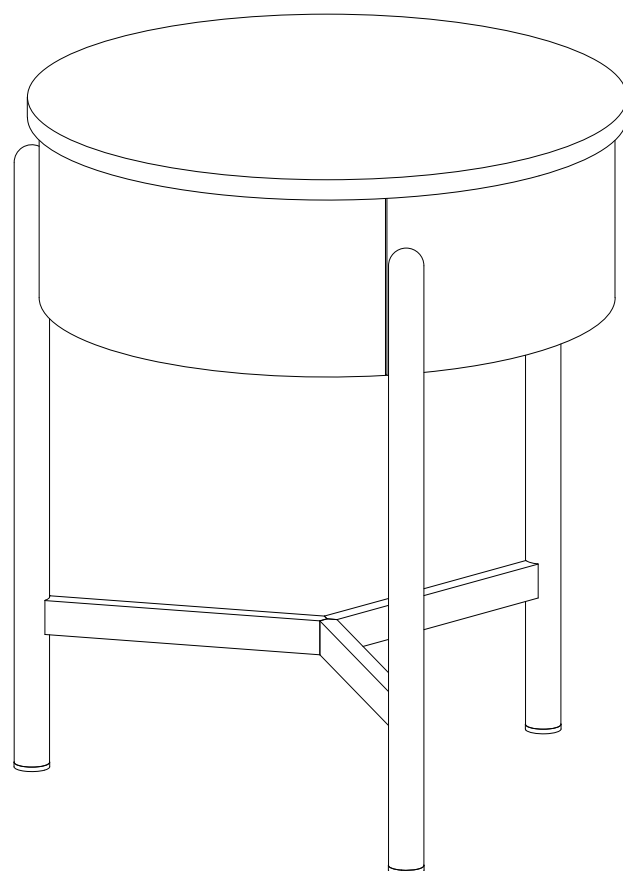
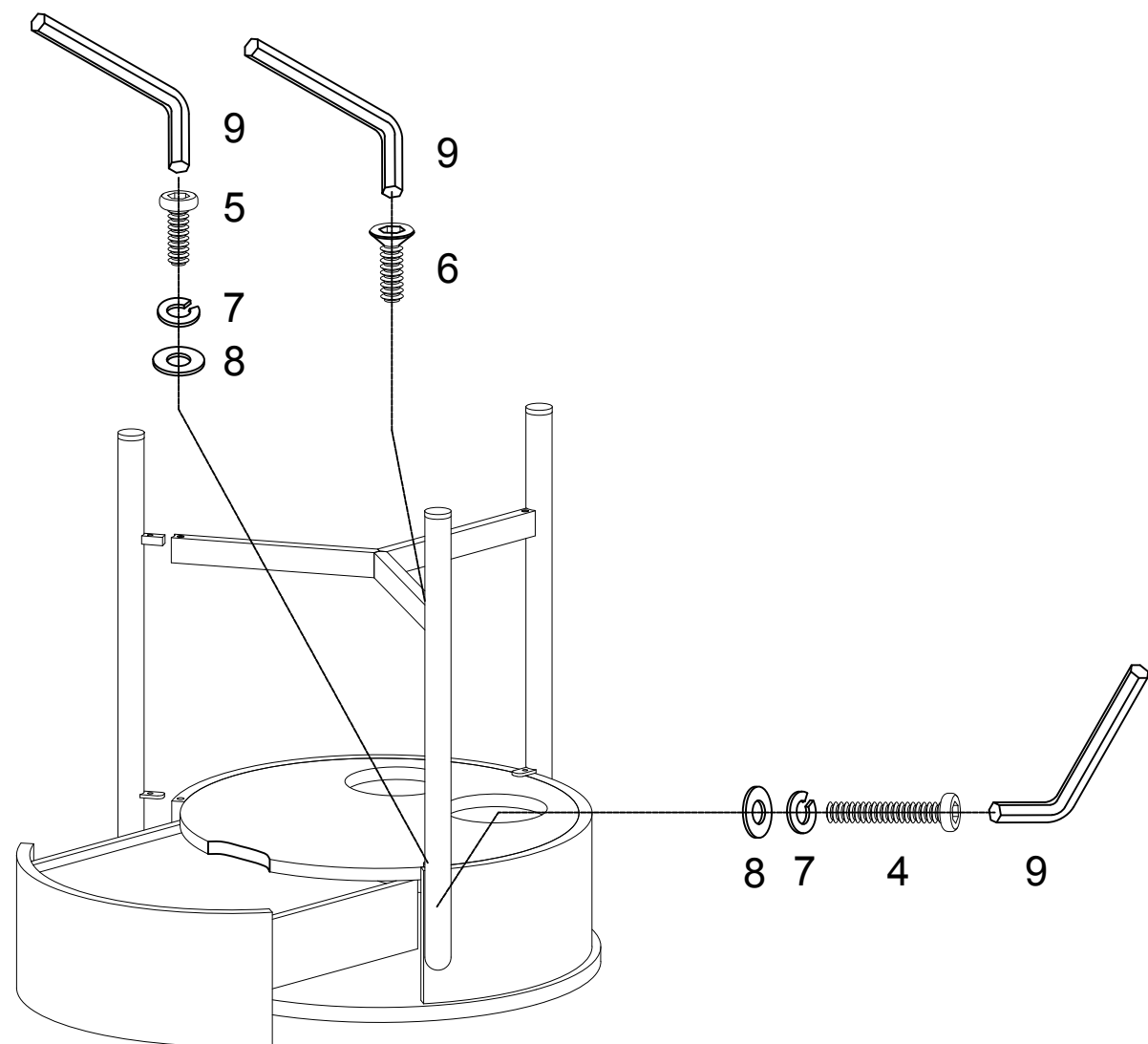

Complete. Congratulations on your assemble success.