

INSTRUCTION MANUAL

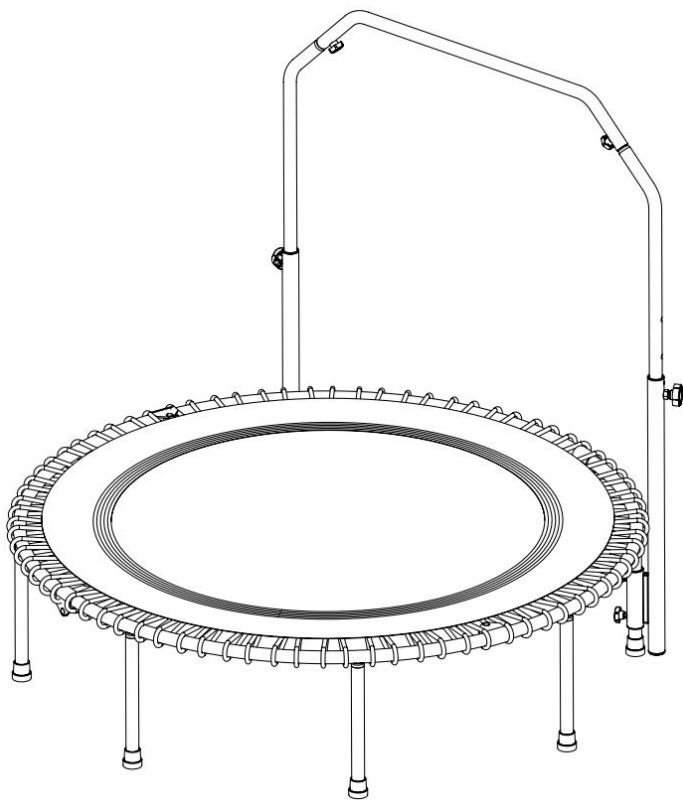

CONTENTS

Warnings.....	2-4
Trampoline Parts List	5
Assembly Instructions	6-11
Maintenance	11

NOTE: Before assembly, compare all the parts with the parts list. If any parts are missing or damaged, do not attempt to assemble, and please contact customer service for replacement.

WARNINGS

DANGER



NO FLIPS!



ONLY ONE user at one time!
(Maximum weight: 330 lb/ 150 kg).



DO NOT USE if you
were injured!



Remove all hard or
sharp objects
before jumping!



DO NOT USE if
pregnant!

Daily Inspection Before Using:

- Ensure legs are tightly screwed and not cracked.
- Ensure springs are not loose or damaged.
- Ensure triangle metal is not twisted or cracked.
- Ensure mat and stitching is not torn.

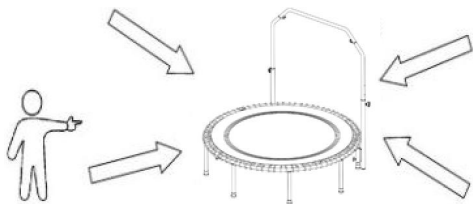

INSPECT BEFORE USING —Check that the legs are properly attached and stable on the ground, no loose springs, mat is in proper place without tears.

WARNINGS











- Consult your physician before beginning this or any exercise or diet program; if you feel dizziness, nausea, chest pain, back pain or other abnormal symptoms, STOP your workout CONSULT A PHYSICIAN IMMEDIATELY before continuing.
- Misuse and abuse of the Trampoline is dangerous and can cause serious injuries including death.
- Trampoline, being a rebound device, can propel the user to unaccustomed heights and into a variety of body movements.
- It is the responsibility of the owner to ensure that the trampoline are adequately learn of all warnings and safety instructions.
- This product is perfect for adults and teen. Please keep eyes on children under 6 years old.
- **Maximum weight limit is 330 lb/ 150 kg.**

WARNINGS -USER INSTRUCTIONS





To stop bouncing, flex knees as feet come in contact with the trampoline mat. Learn this skill first.

- Avoid bouncing too high. Stay low to maintain bounce control and always land at the center of the trampoline. Control is most important in bouncing.
- Adequate overhead clearance is essential. A minimum of (10 ft) from ground to top. Away from wires, ceiling fans, and other possible hazards.
- Lateral clearance is essential. Place the trampoline away from walls, structures, furniture, and other play areas. Ensure a clear space of 6 ft (1.8 m) on all sides of the trampoline.
- Remove any items under the trampoline.
- Don't use the trampoline in the dark. Artificial lighting may be required.
- Do not allow more than one person on the trampoline. Use by more than one person at the same time may result in serious injuries.
- Indoor and outdoor use.

TRAMPOLINE AND PARTS LIST

Number	Part Picture	Description	Quantity
1		Main Frame with Jump Mat (Pre-assembled with rope and mat)	1
2		Elastic rope (Pre-assembled with #1)	40
3		Leg with Cap	8
4A		Handrail Leg-Right	1
4B		Handrail Leg -Left	1
5		Handle bar with foam	1
6A		Handrail Support -Right	1
6B		Handrail Support-Left	1
7		Leg Socket Cap (Pre-assembled with #1)	8
8		Leg Post Cap (Pre-assembled with #3)	8
9		Protector	1

Hardware

Number	Hardware Picture	Description	Quantity
A		M8 Adjustment Knob	2
B		M6 Adjustment Knob	6
C		T hook	1
D		Elastic rope hook	1

ASSEMBLY INSTRUCTIONS

Step 1

> Open the frame and mat (#1), put the trampoline face down on surface, press hard on the frame until it remains flat.

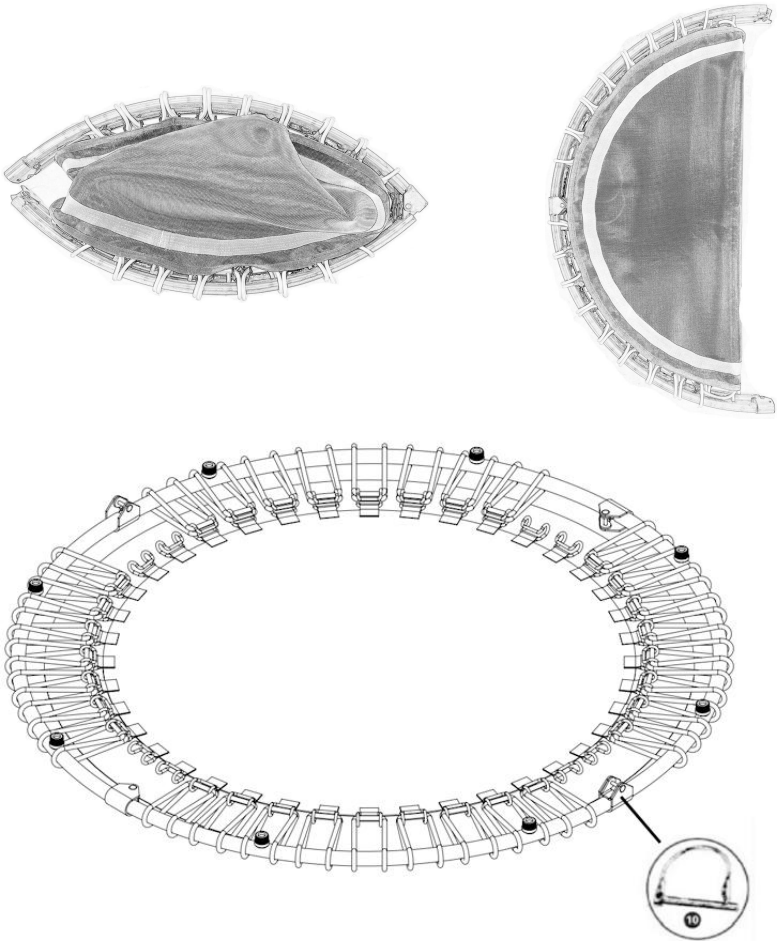

ASSEMBLY INSTRUCTIONS

Step 2 - Install the elastic rope

>Use the tools to install the elastic rope one by one.(#2)

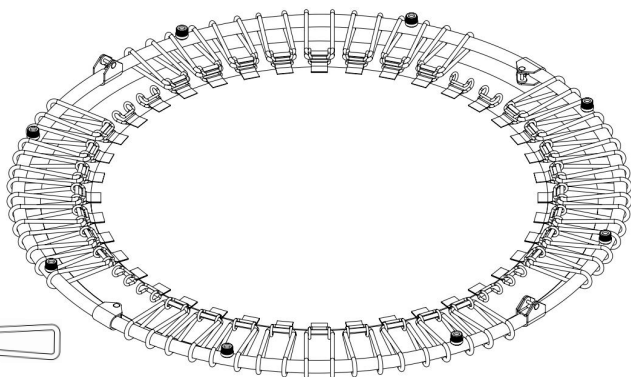
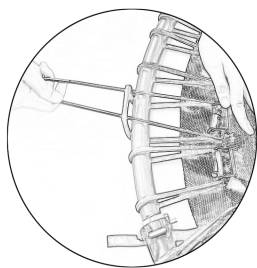

If the rope falls out, you can use tool 'D' to put the rope back on.

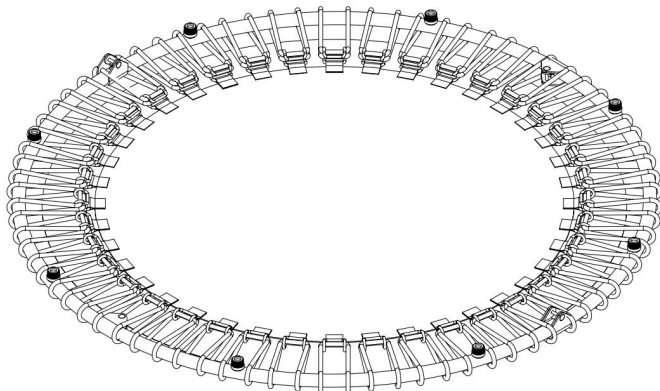

ASSEMBLY INSTRUCTIONS

Step 3 -Attach Leg to the Trampoline

> Tightly screw Leg onto the leg sockets (#3) of the trampoline frame.

ATTENTION!!!: All the Legs(#3), Leg Caps must be screwed tightly, and Legs (#3) must be flat on the ground to avoid wobbling during use.

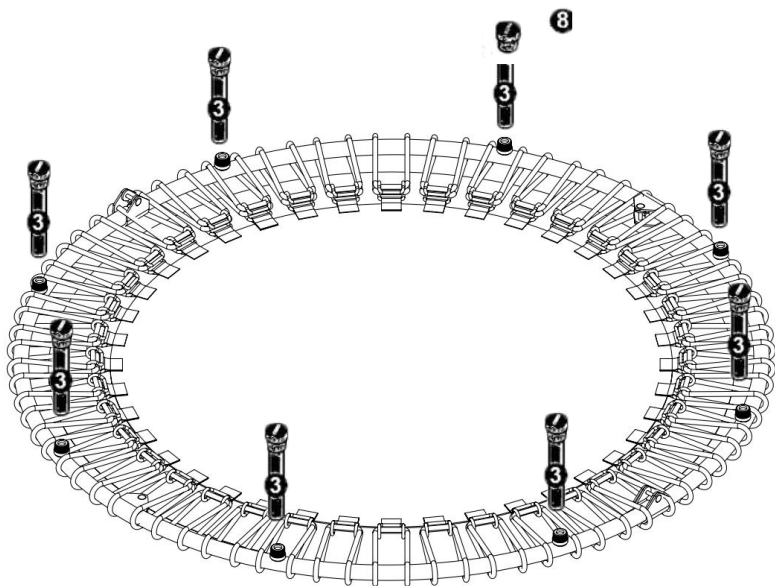

ASSEMBLY INSTRUCTIONS

Step 4-Assemble Handle Bar

> Lift the trampoline to a standing position. Attach Handrail Legs (#4A and #4B) to the two front legs without the caps, use Adjustment Knob to secure. DO not screw tightly until the next step(#B), then place Leg Cap (#8) onto the handrail legs.

Please note that when you install the handrail, place the part 'S' between the two handrails.

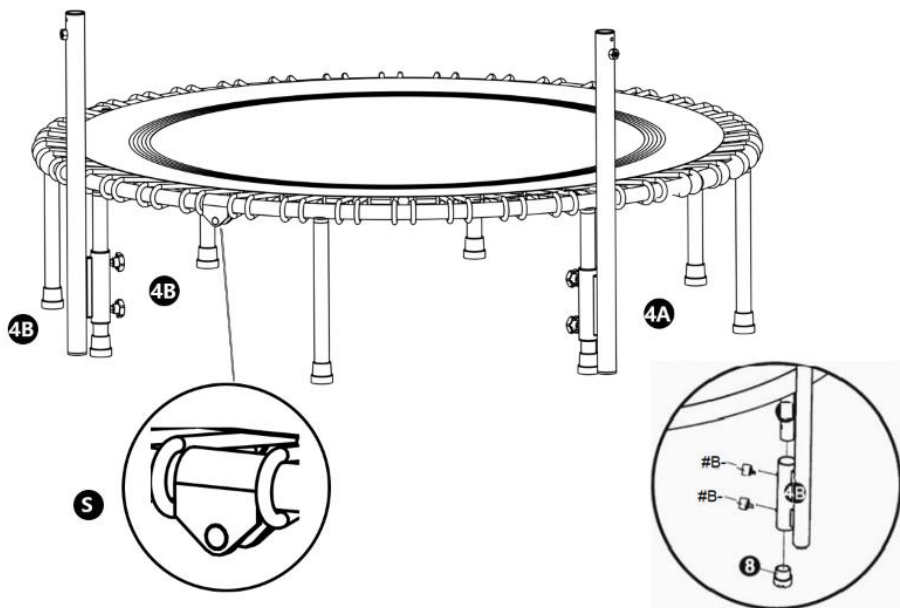

ASSEMBLY INSTRUCTIONS

Step 5 - Assemble Handle Bar Support

> Attach Handrail Support (#6A and #6B) to each side of Handle Bar (#5). Triangle Adjustment Knobs (#B) are secured tightly on each side.

> **Connect the assembled handle bar to Handrail Leg Supports (#4A and #4B) and secure tightly with Adjustment Knob (#A) at the appropriate height level.**

!!Attention!!! All the Legs (#3), Leg Caps (#8) and Knobs must be screwed tightly, and Legs (#3) must be flat on ground to avoid wobbling when use.

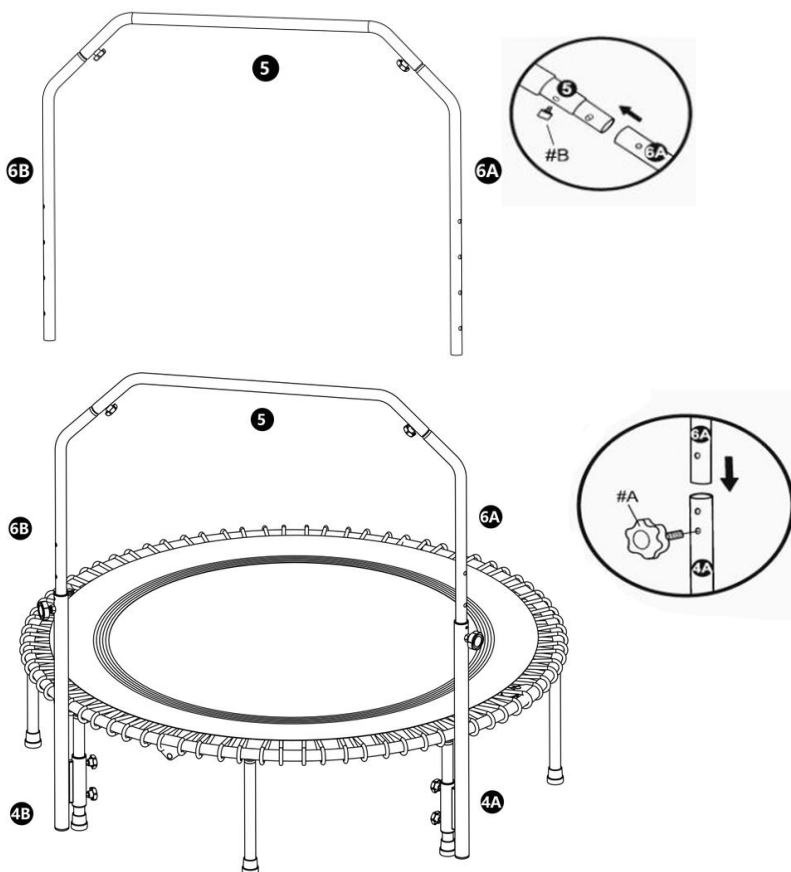

ASSEMBLY INSTRUCTIONS

> The trampoline should look as shown below when completed. Inspect the entire trampoline and make sure all parts are properly secured before using

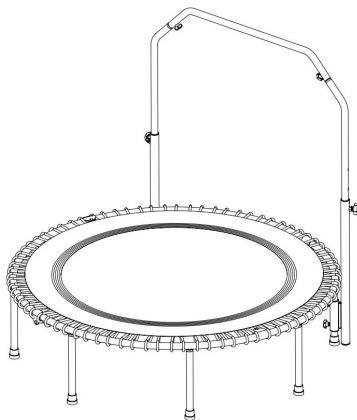

MAINTENANCE



Failure to comply with these instructions and proper operating condition of your trampoline may lead to serious injury or death.

!!WARNING!!!

>The trampoline must be inspected prior to use. The legs should be locked securely. If any parts become damaged or worn, please stop using the trampoline immediately and replace with authorized parts.

>If you find any signs of damage to springs, do not use the trampoline. Please contact our customer service representatives to order/replace the original parts.

>Please pay attention that the following conditions could represent potential hazards:

- Fabric of the mat or frame padding aging
- Bent or broken support system (frame)

