

ASSEMBLY INSTRUCTION

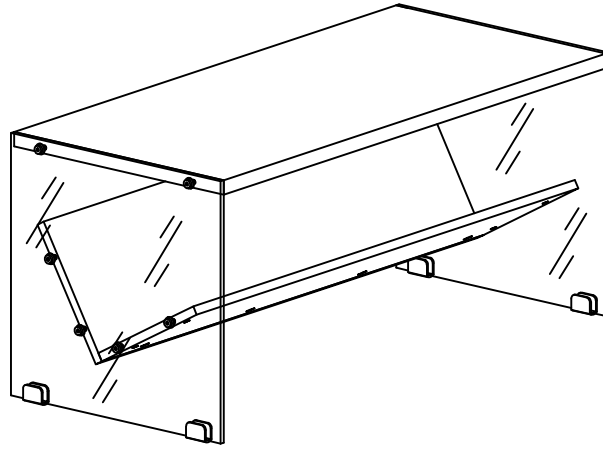

1

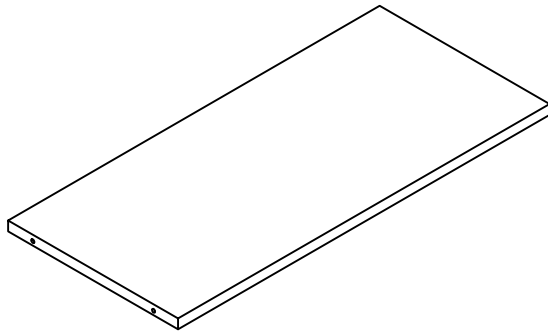

1PC

2

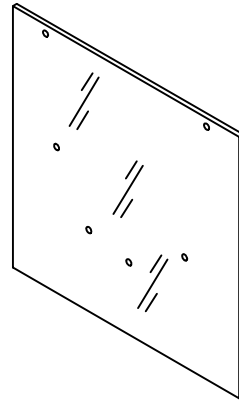

2PCS

3

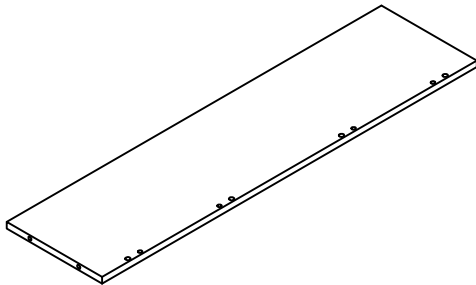



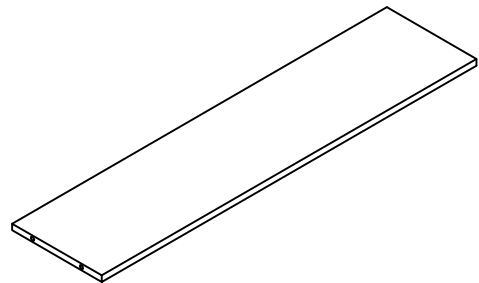



























1PC



1PC

ASSEMBLY INSTRUCTION

Hardware				Accessories			
NO.	PICTURE	SIZE	QTY	NO.	PICTURE	SIZE	QTY
A	 		4	B	 		4
C	 		4	D	 	M6	12
E	 	M6*45	12	F	 	M6	12
G	 	M6*16	12	H			4
I			1				

Spare							
NO.	PICTURE	SIZE	QTY	NO.	PICTURE	SIZE	QTY
A	 		1	B	 		1
C	 		1	D	 	M6	1
E	 	M6*45	1	F	 	M6	1
G	 	M6*16	1	H			1

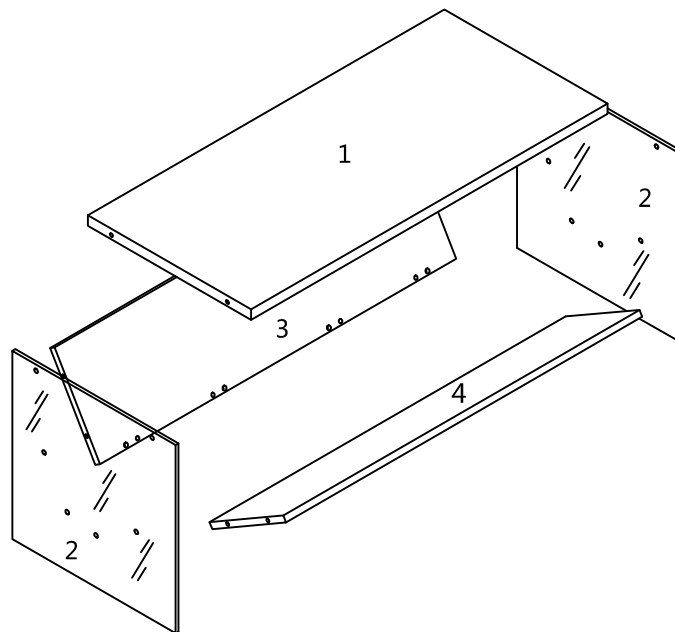

Decomposition Diagram

ASSEMBLY INSTRUCTION

STEP 1

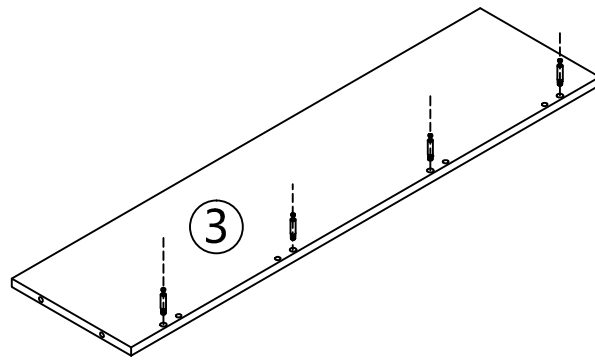
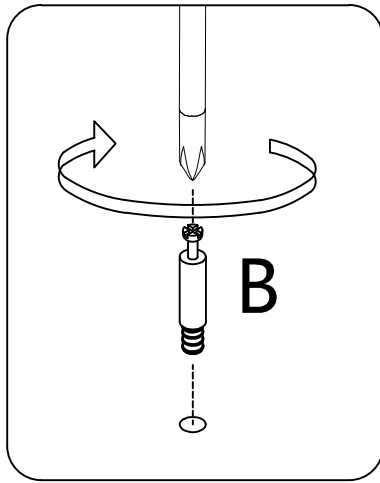

B= 4 X 

STEP 2

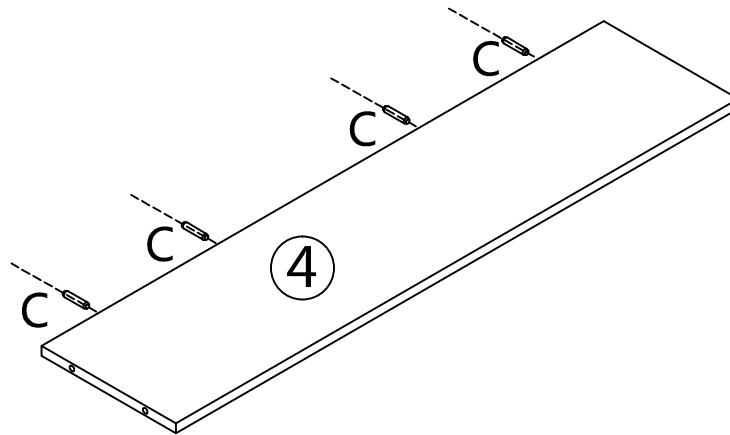

C=4 X 

ASSEMBLY INSTRUCTION

STEP 3

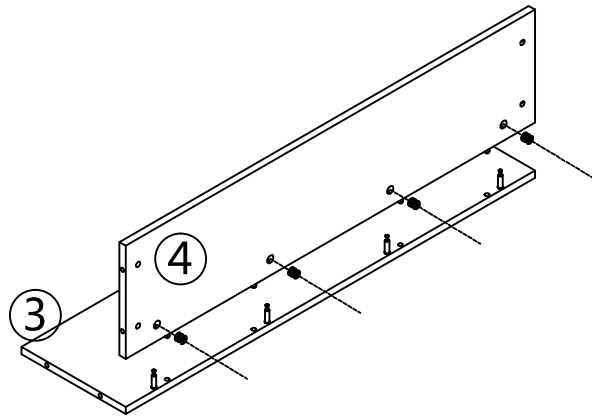
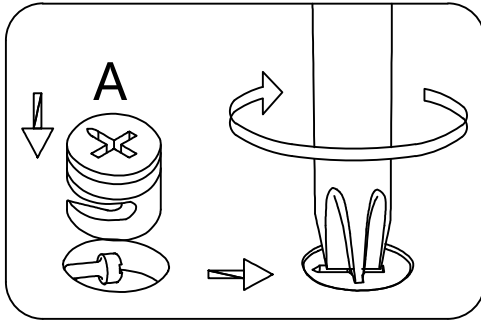

A= 4 X 

STEP 4

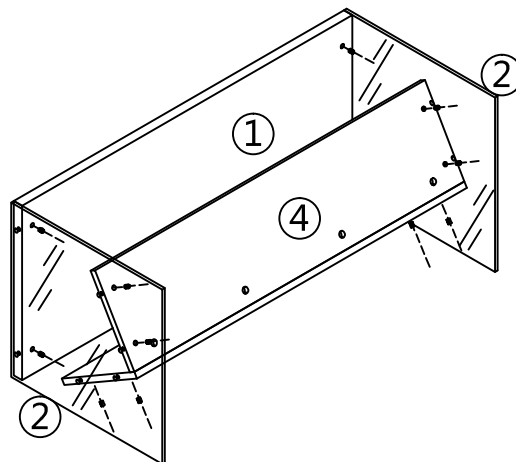
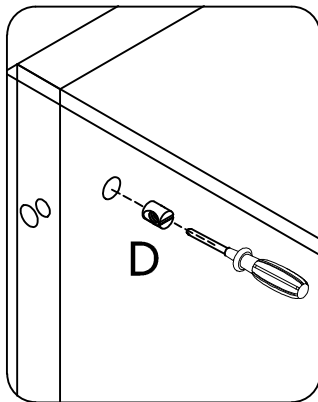

D=12 X 

ASSEMBLY INSTRUCTION

STEP 5

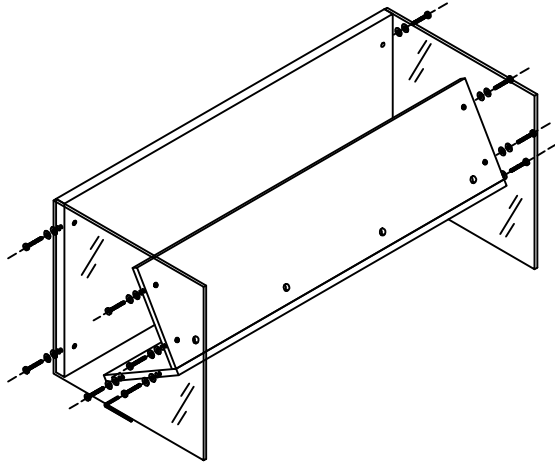
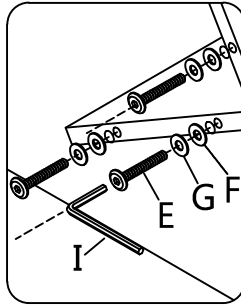

Notes: Please do not use power drill, use allen key provided. Do not use desk before assembling completely. Please put all of these screws into the holes and just screw 20%-40% of every screw firstly, then fasten all of the screws.

E=12 X 

F=12 X 

G=12 X 

I=1 X 

STEP 6

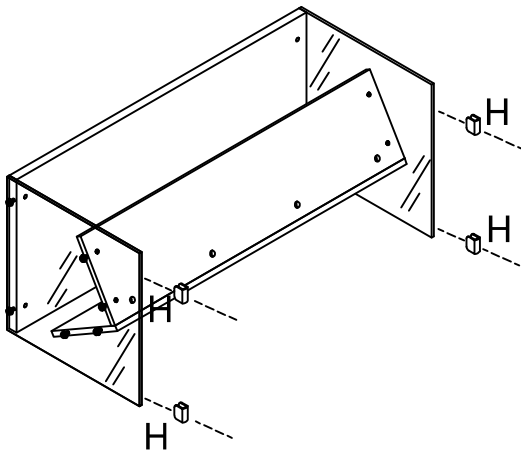

H=4 X 

STEP 7

