

Assembly Instruction

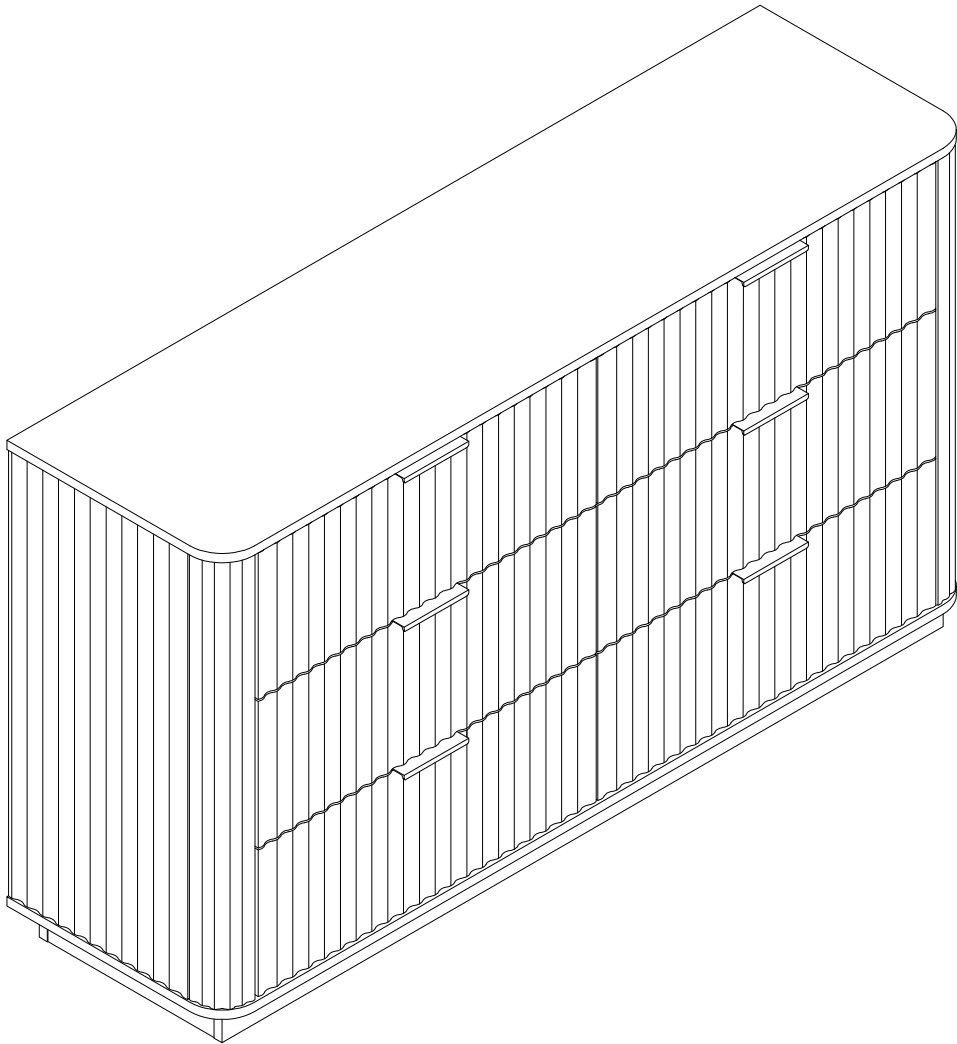

General Guidelines

- Please read the following instruction carefully and use the product accordingly.
- Please keep this manual and hand it over when you transfer the product.
- This summary may not include every detail of all variations and considered steps. Please contact us when further information and help are needed.

Notes

- The product is intended for indoor use only. The product must be assembled and used in accordance with the provisions of the manual. Personal injury and/or damage to product may occur if products are used outside of their intended purposes and/or if products have been changed/modified from their original design. The seller does not assume any responsibility or liability with respect to any injury/damage caused by incorrect assembly or improper use.
- Avoid long-term exposure to humid environments to prevent mildew.
- Keep the product away from fire sources and high temperatures. Do not expose the product to direct sunlight.
- Do not place any hot objects on the surface of the product.
- If there are any defective or missing parts after unpacking, please cease assembly immediately and contact us.
- Please assemble the item on a spacious surface and do not place the unwrapped product directly on the ground to avoid product damage.
- Please do not stand or sit on the wooden boards.
- Please wear gloves during the assembly and/or disassembly process to avoid scratches from any sharp edges.
- Please match the corresponding part and fitting based on the part number in the manual.
- If the part does not match with the fitting, please check the piece as specified in this manual.
- During assembly, first loosely align all screws with the corresponding pre-drilled holes and then tighten the screws one by one.
- Periodically inspect screw tightness while the product is in use. If necessary, retighten to ensure structural integrity.
- If you accidentally spill water or another liquid on the surface, immediately wipe clean with a dry towel.
- Please keep the product away from sharp, pointed objects and corrosive substances to prevent product damage.
- Please place this item on level, solid ground during use.

Warnings

- During assembly, keep all small parts out of the reach of children. It may be fatal if swallowed or inhaled.
- Children should not climb or play on the product in order to avoid tipping over the furniture and causing serious injury.
- To avoid the potential dangers of suffocation, please keep all parts and packaging (film, plastic bags, foam, etc.) away from babies and children.
- Keep sharp objects and corrosive items away from the product to avoid any damage or injury.
- Do not shake or move violently during use to avoid tipping over the product.

Parts List (EN)

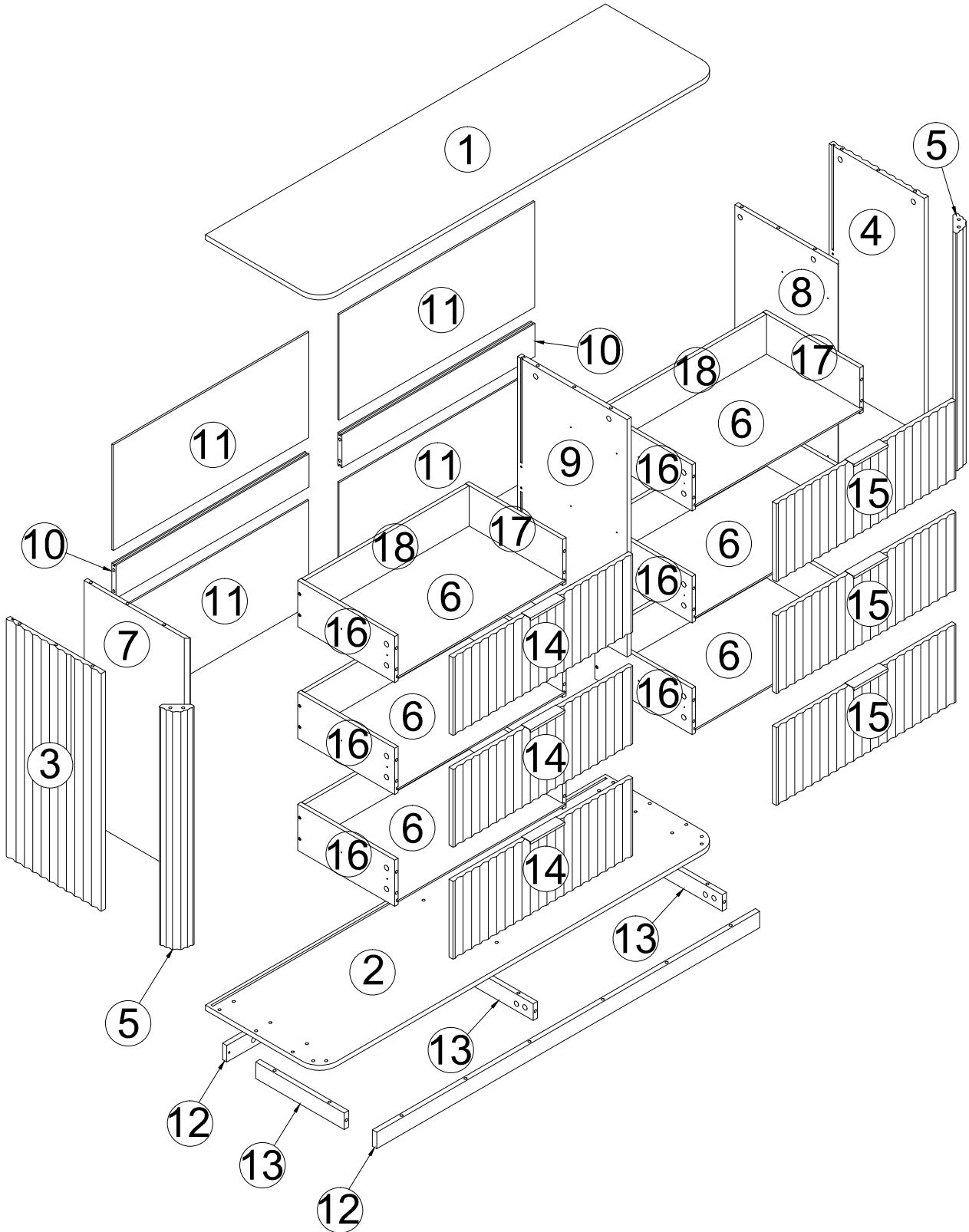



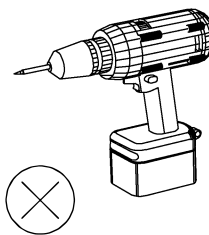
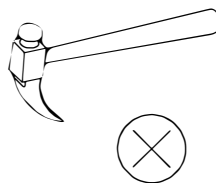
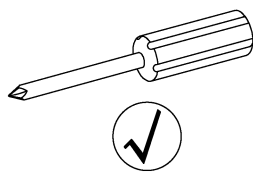
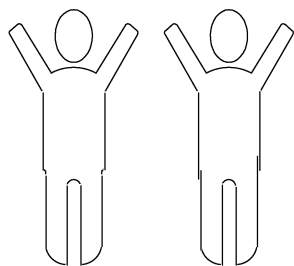





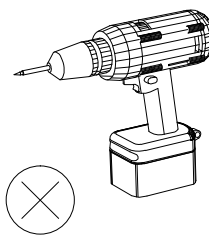
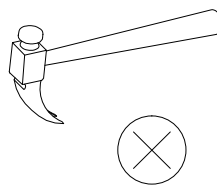
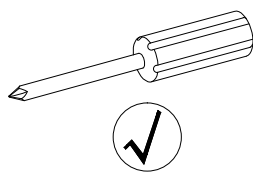
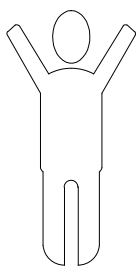
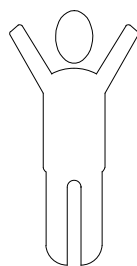



Parts List (EN)

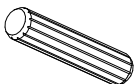
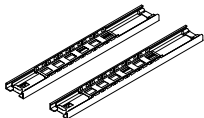

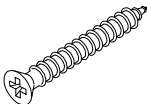
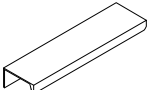
<p>①</p> <p>1PCS</p>	<p>②</p> <p>1PCS</p>	<p>③</p> <p>1PCS</p>	<p>④</p> <p>1PCS</p>
<p>⑤</p> <p>2PCS</p>	<p>⑥</p> <p>6PCS</p>	<p>⑦</p> <p>1PCS</p>	<p>⑧</p> <p>1PCS</p>
<p>⑨</p> <p>1PCS</p>	<p>⑩</p> <p>2PCS</p>	<p>⑪</p> <p>4PCS</p>	<p>⑫</p> <p>2PCS</p>
<p>⑬</p> <p>3PCS</p>	<p>⑭</p> <p>3PCS</p>	<p>⑮</p> <p>3PCS</p>	<p>⑯</p> <p>6PCS</p>
<p>⑰</p> <p>6PCS</p>	<p>⑱</p> <p>6PCS</p>		

Parts List (EN)

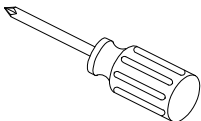

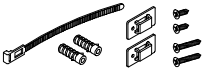
<p>No. A Quantity:62+3 Pcs Cam Lock Dowel 8*28mm</p> 	<p>No. B Quantity:62+3 Pcs Cam Ø15</p> 	<p>No. C Quantity:6+1 Pcs Sticker Ø20</p> 	<p>No. D Quantity:18+1 Pcs Dowel 8*30mm</p> 
<p>No. E Quantity:6 Sets Drawer Slider 10"</p> 	<p>No. F Quantity:60+3 Pcs Screw M3.5*12mm</p> 	<p>No. G Quantity:24+2 Pcs Screw M4*30mm</p> 	<p>No. H Quantity:6 Pcs Handle</p> 
<p>No. I Quantity:6+1 Pcs Foot Pad Ø15</p> 	<p>No. J Quantity:14+1 Pcs Screw M6*40mm</p> 	<p>No. K Quantity:1 Pcs Allen Key 4#</p> 	<p>No. L Quantity:1 Pcs Screwdriver</p> 
<p>No. M Quantity:16+1 Sets Plastic Wedge</p> 	<p>No. N Quantity:1 Sets Anti-falling Parts</p> 		

Instructions For Fastening CAM-BOLT and CAM-LOCK

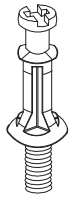

CAM-BOLT

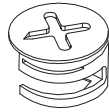

CAM-LOCK

Tools Required

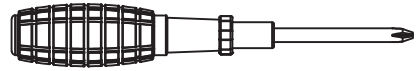

INSERTING AND TIGHTENING CAM-BOLT

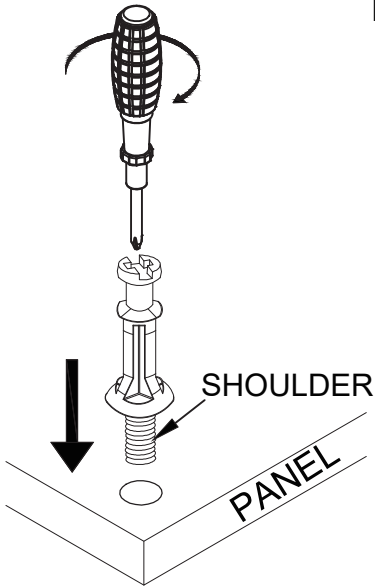

Place Cam-bolt on pre-drilled hole and screw in vertically

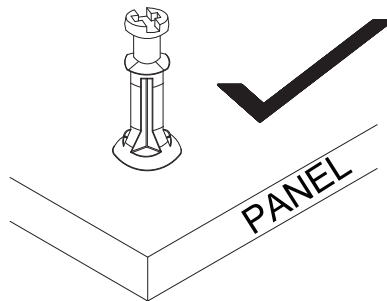

Shoulder is flushed (on the same level) with the panel.

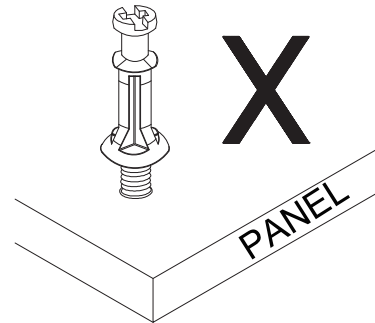

Shoulder is above the panel.

Place Cam-bolt on the designated pre-drilled holes on the panel. Use a Phillips Screwdriver to screw-in Cam-bolt vertically until shoulder is flushed (on the same level) with panel.

INSERTING CAM-LOCK

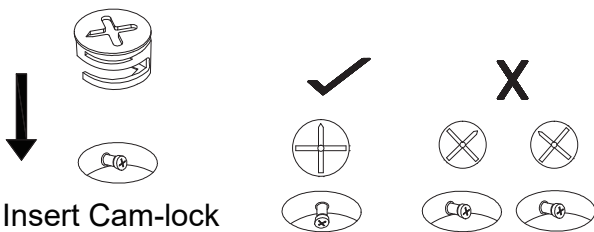

Insert Cam-lock with arrow align to Cam-bolt head

CORRECT

WRONG

TIGHTENING CAM-LOCK

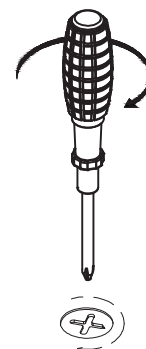

Align the arrow on the Cam-lock to the Cam-bolt head and insert the Cam-lock. Ensure Cam-lock is fully inserted.

Use a Flat-head Screwdriver to turn Camlock clockwise so it locks onto the head of the Cam-bolt. Turn until it is snug (about 3/4ths of a turn) -- over-tightening could damage Cam-lock or/and Cam-bolt.

STEP 1

Before Assembly

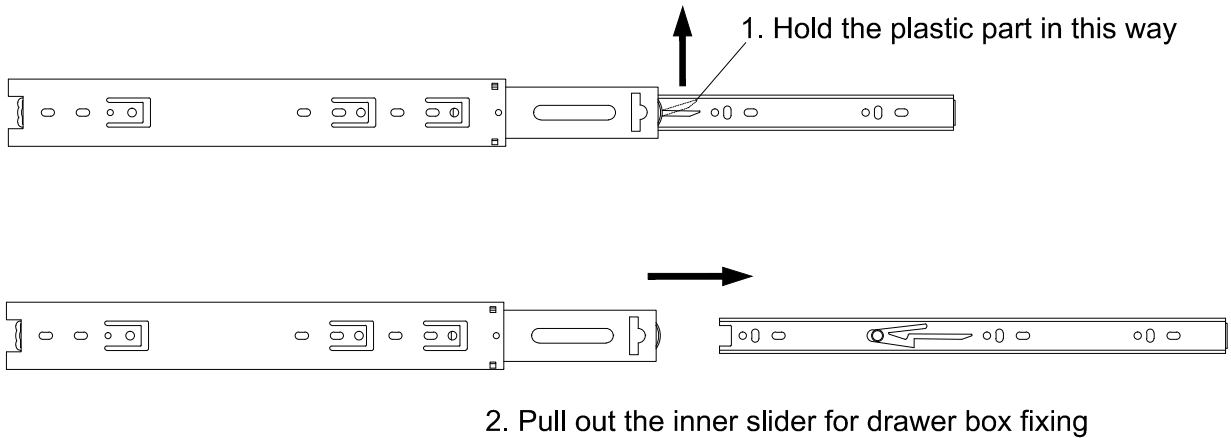

Tips Before Your Start

How to separate the drawer slider:

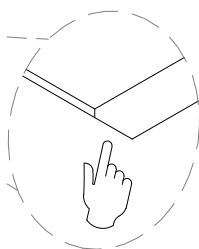
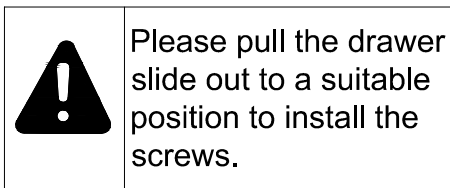
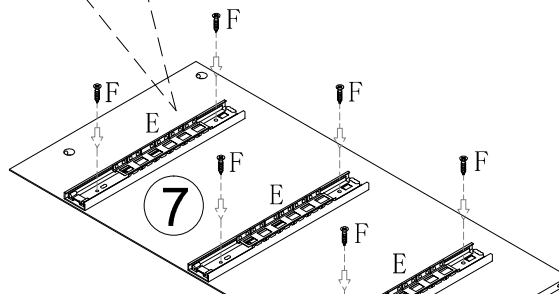
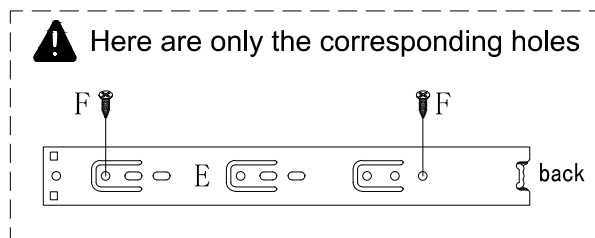

STEP 2



	E×3PCS
	F×6PCS

STEP 3

! Here are only the corresponding holes

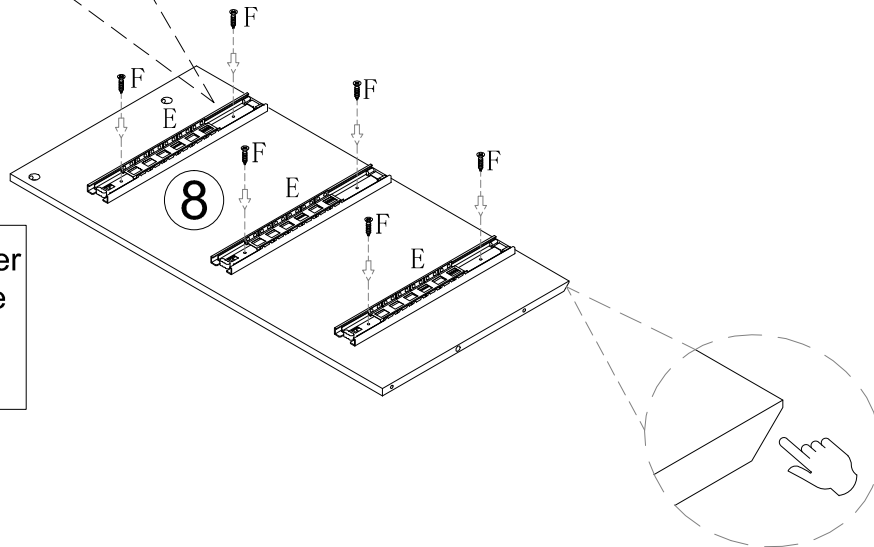
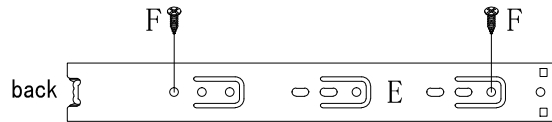

Please pull the drawer slide out to a suitable position to install the screws.

	E×3PCS
	F×6PCS

STEP 4

! Here are only the corresponding holes

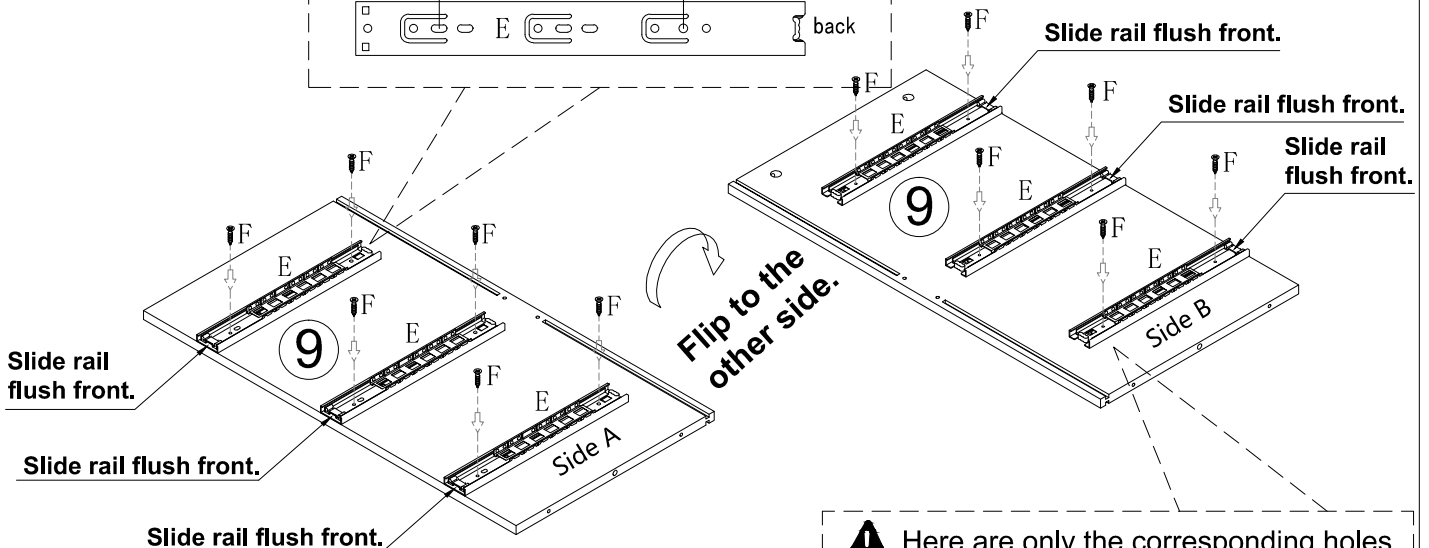
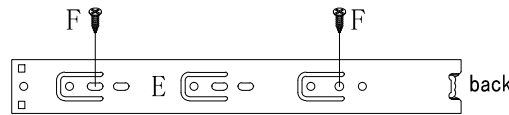

Please pull the drawer slide out to a suitable position to install the screws.

	E×3Sets
	F×12PCS

! Here are only the corresponding holes

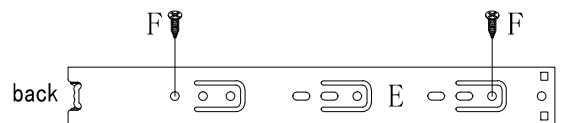

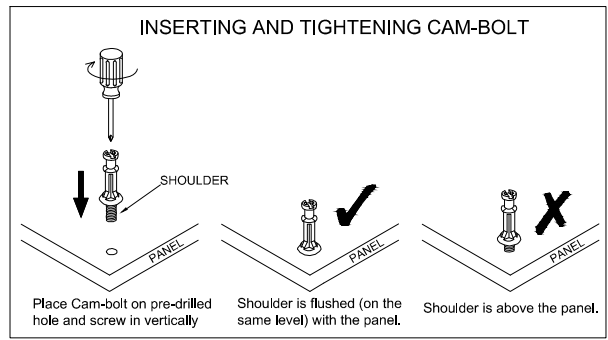
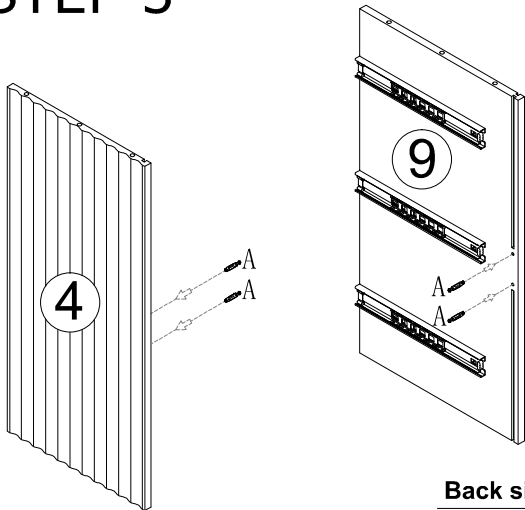

STEP 5

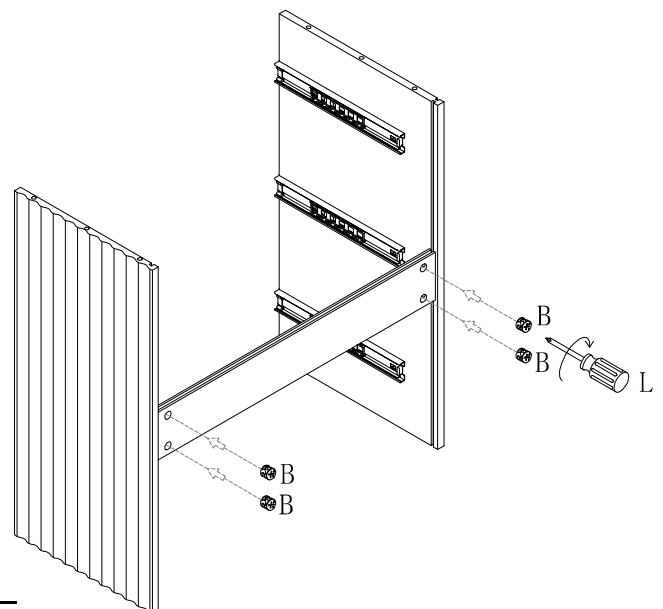
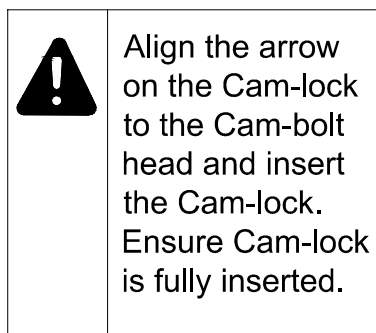
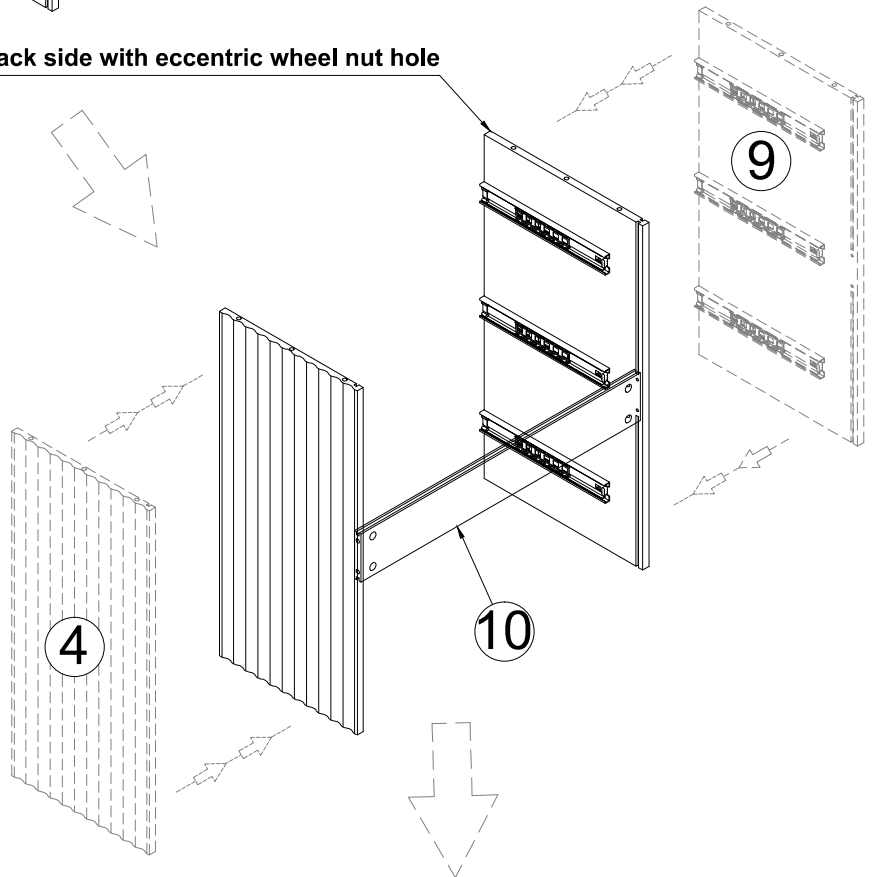
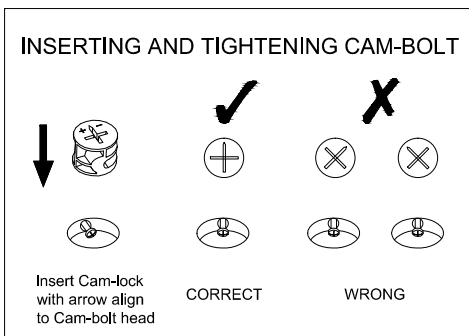

Back side with eccentric wheel nut hole

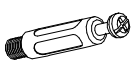

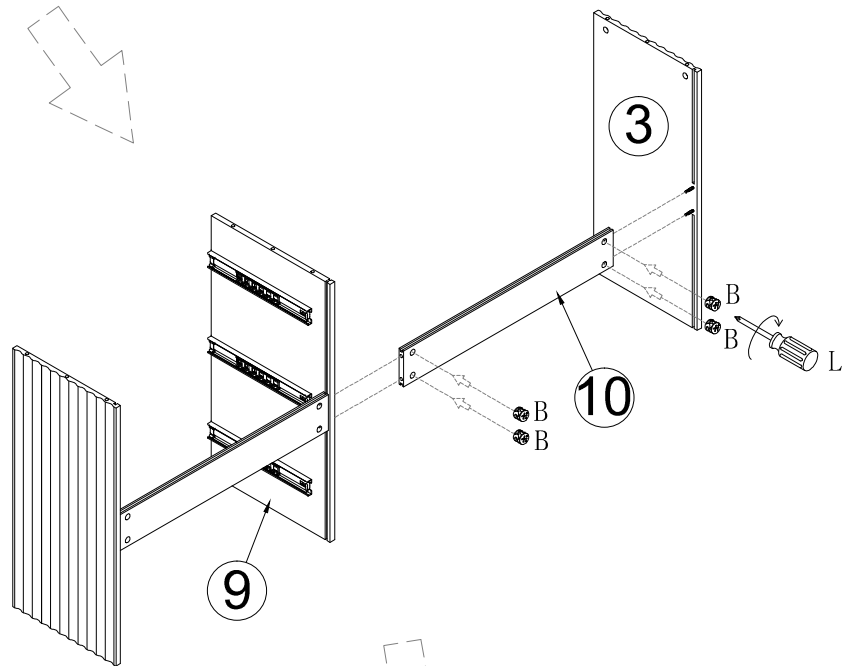
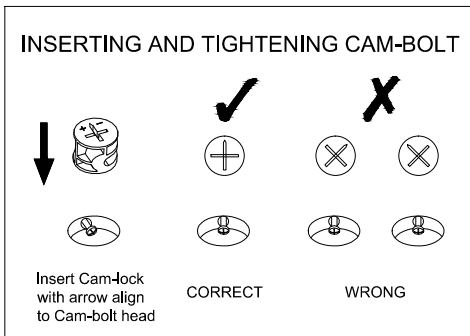
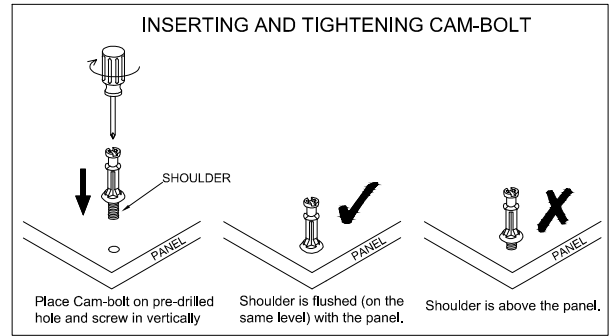
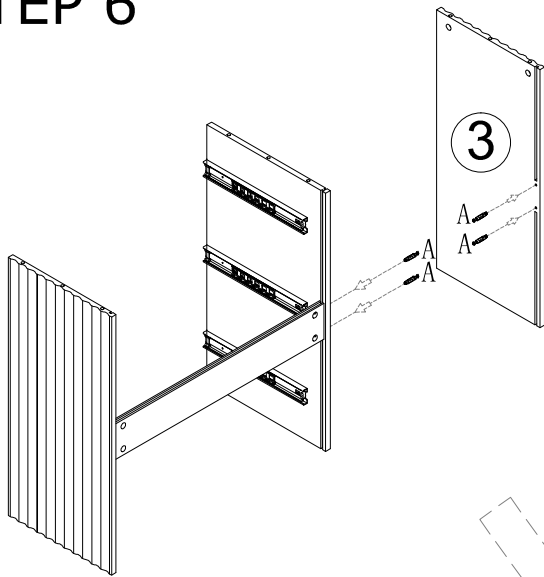

	A×4PCS
	B×4PCS

STEP 6

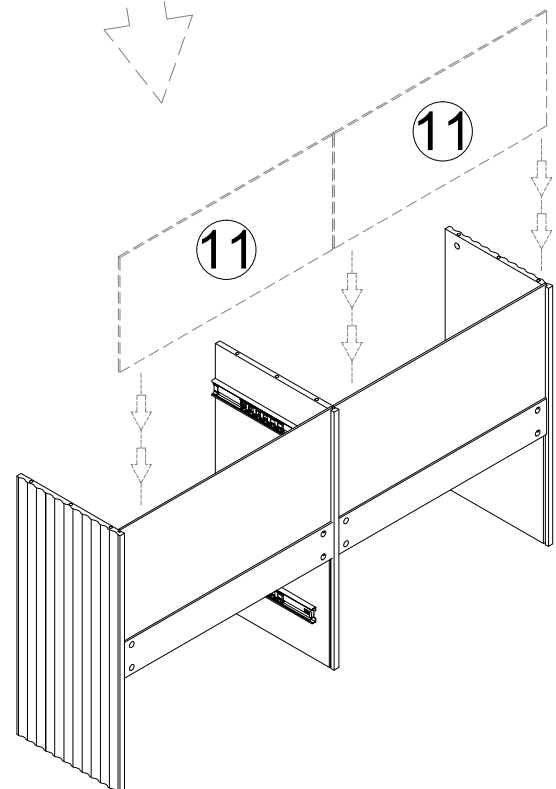

! Align the arrow on the Cam-lock to the Cam-bolt head and insert the Cam-lock. Ensure Cam-lock is fully inserted.

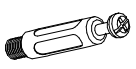

	A×4PCS
	B×4PCS

STEP 7

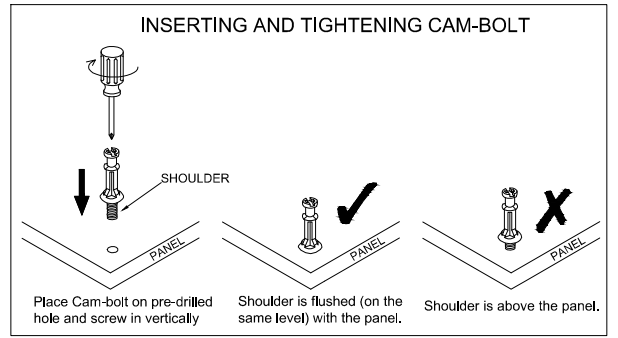
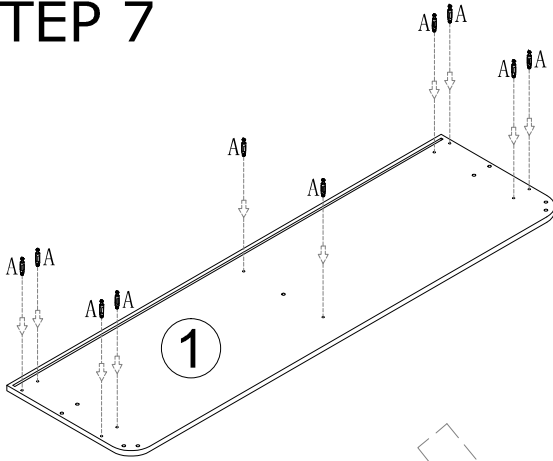

Align the arrow on the Cam-lock to the Cam-bolt head and insert the Cam-lock. Ensure Cam-lock is fully inserted.

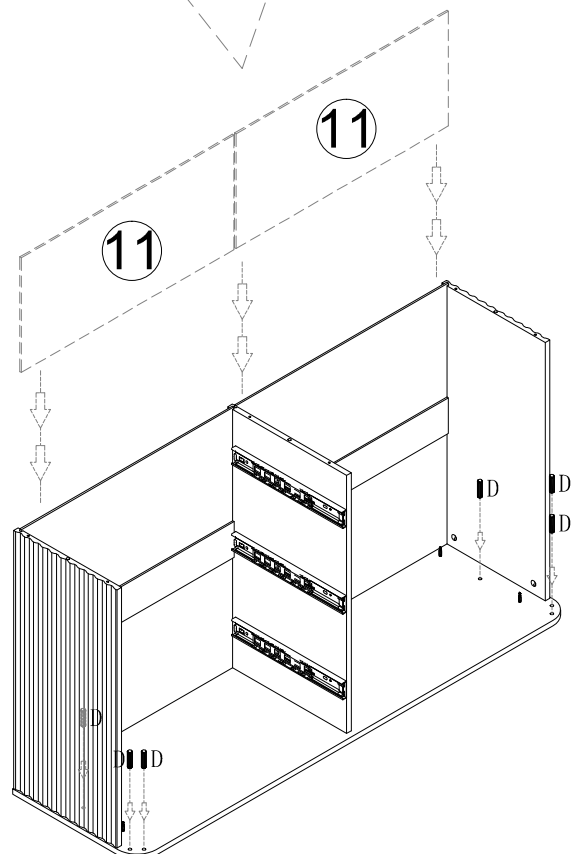
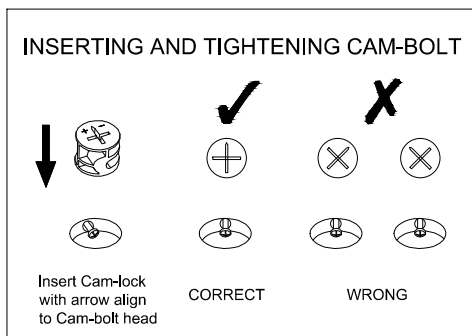
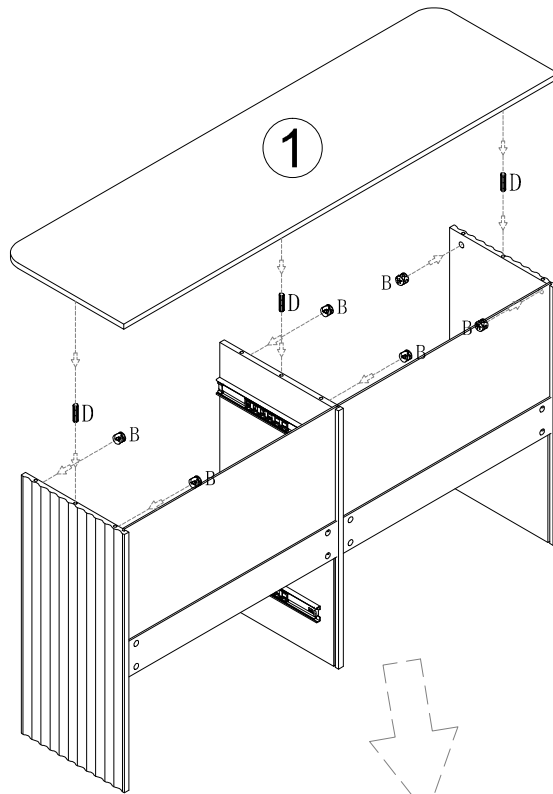

	A×10PCS
	B×6PCS
	D×9PCS

STEP 8

INSERTING AND TIGHTENING CAM-BOLT

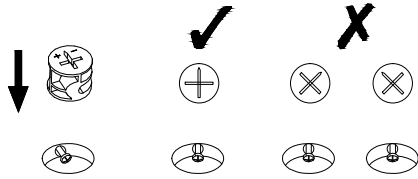

Insert Cam-lock
with arrow align
to Cam-bolt head

CORRECT

WRONG



Align the arrow
on the Cam-lock
to the Cam-bolt
head and insert
the Cam-lock.
Ensure Cam-lock
is fully inserted.



B×4PCS

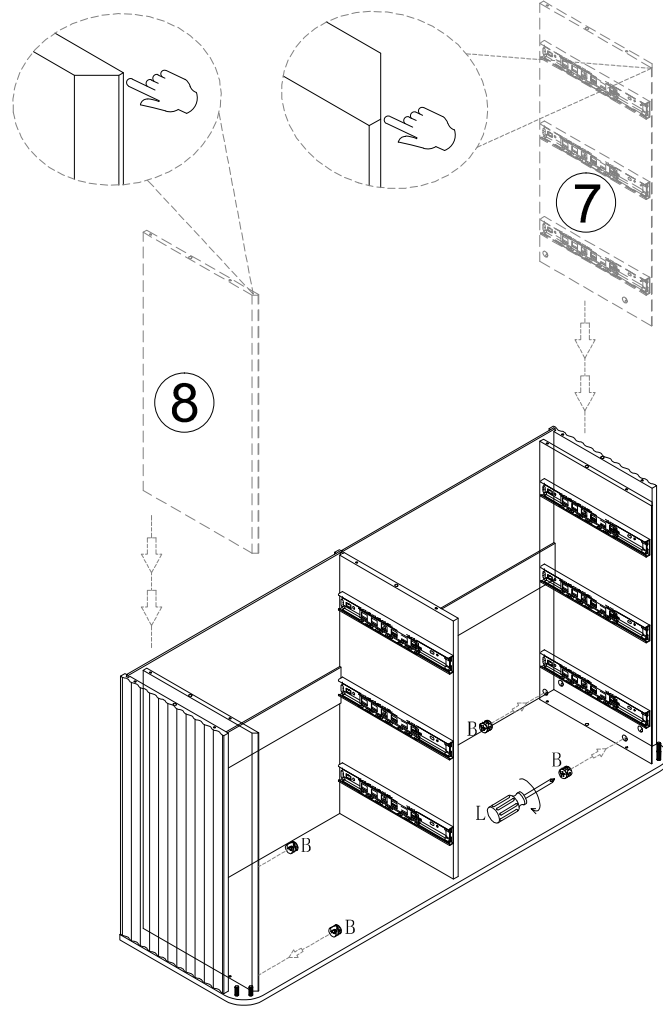

STEP 9

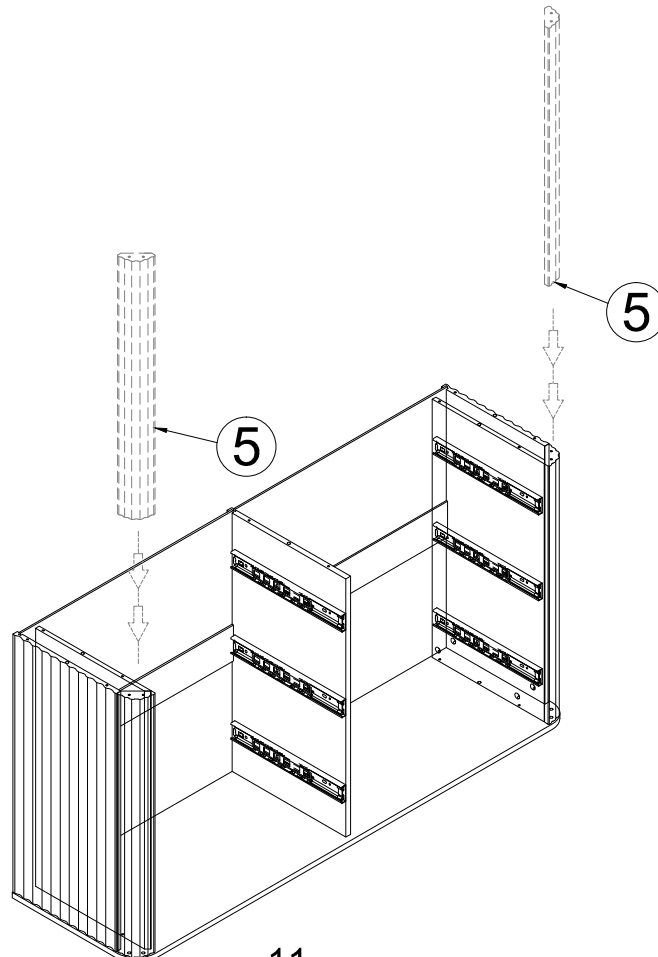

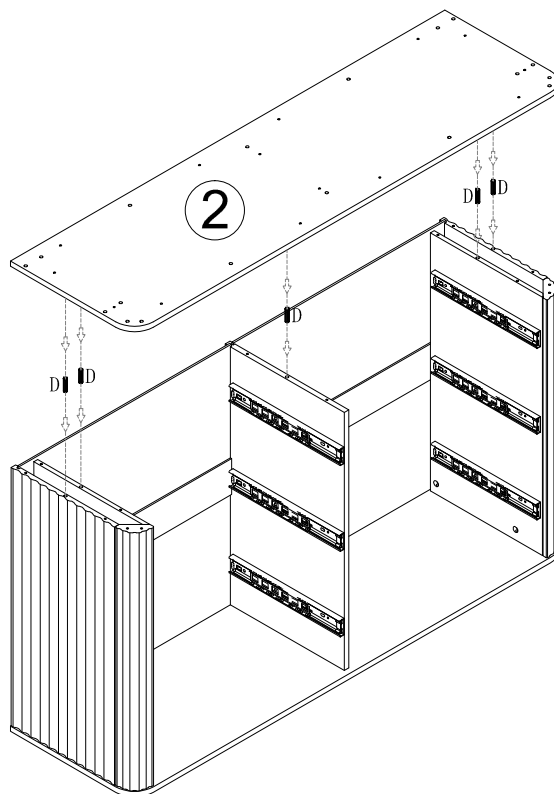

STEP 10

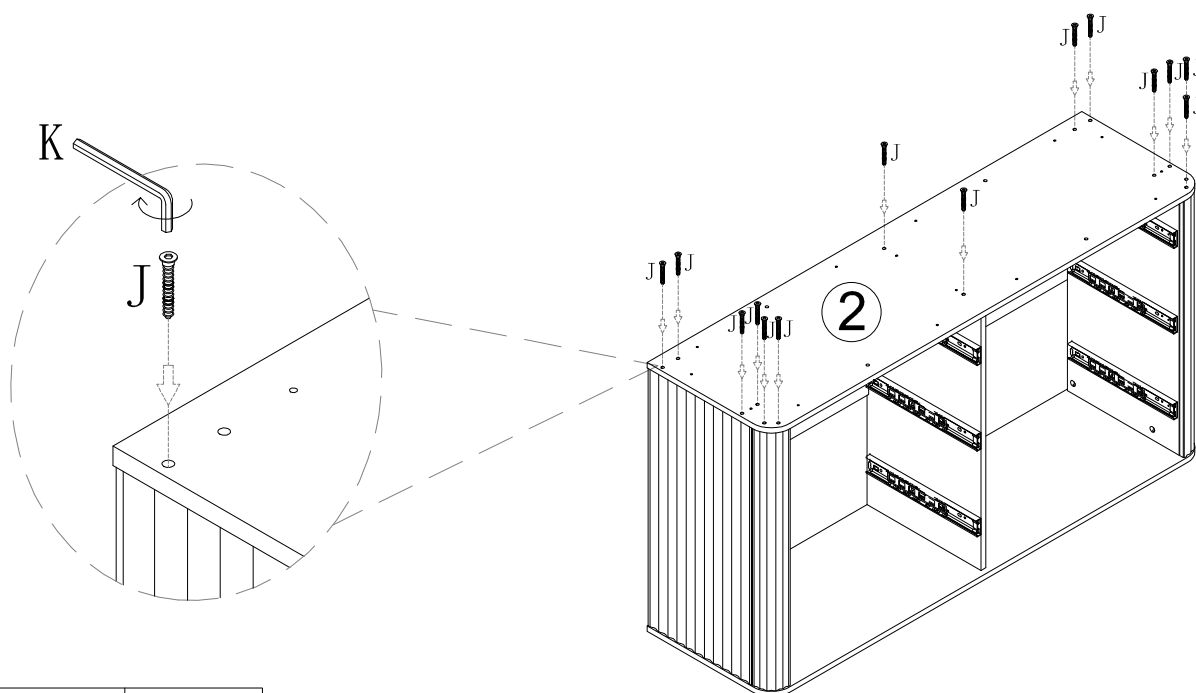

	D×5PCS
---	--------

STEP 11



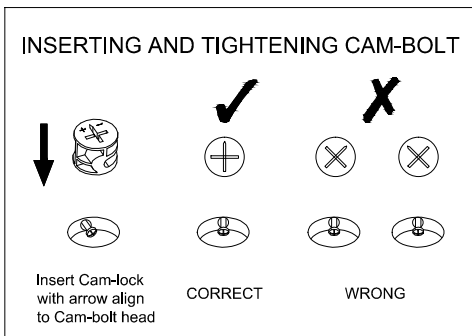
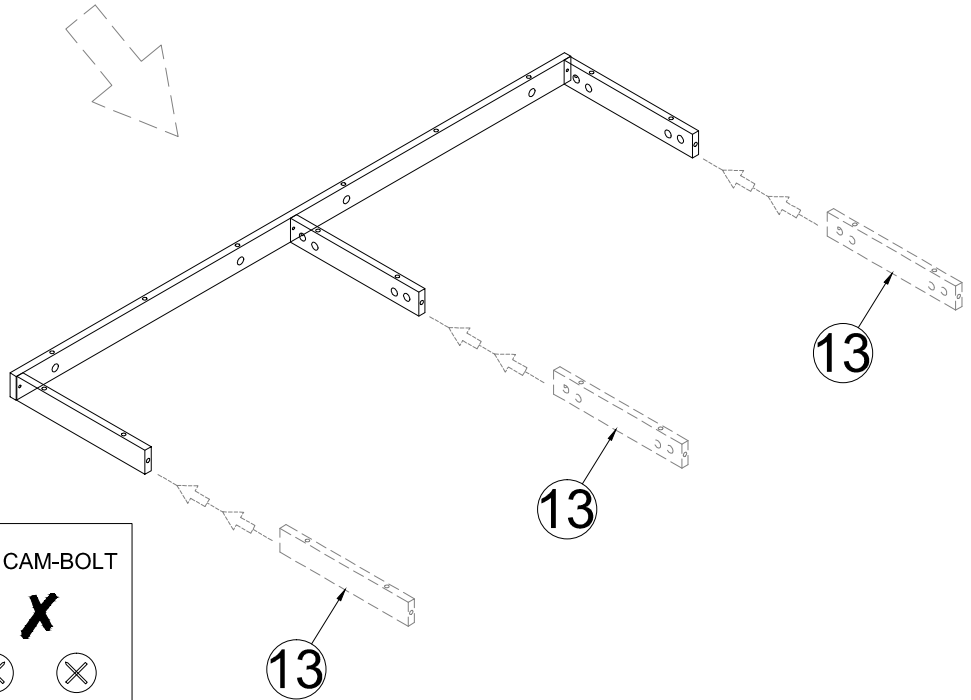
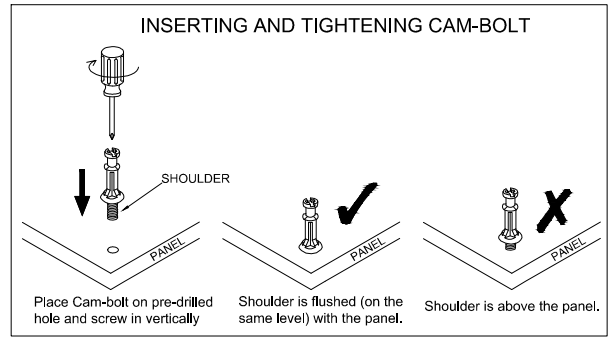
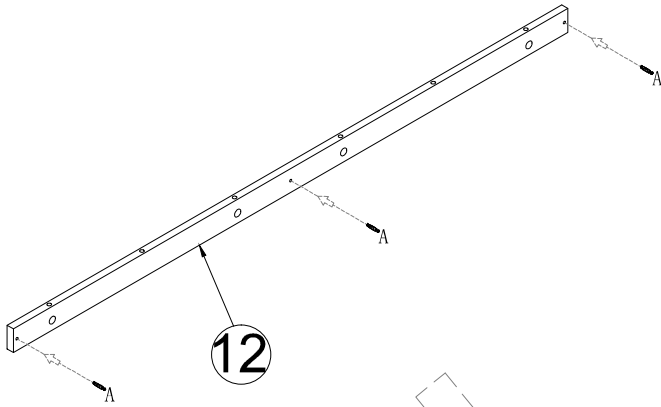

	J×14PCS
	K×1PCS

STEP 12



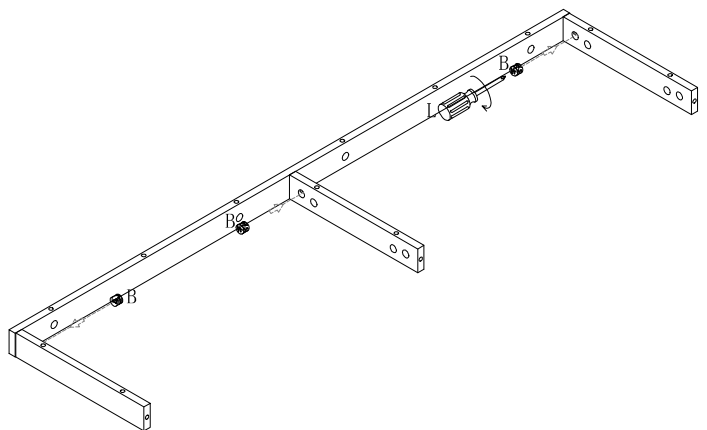

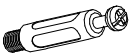
Align the arrow on the Cam-lock to the Cam-bolt head and insert the Cam-lock. Ensure Cam-lock is fully inserted.

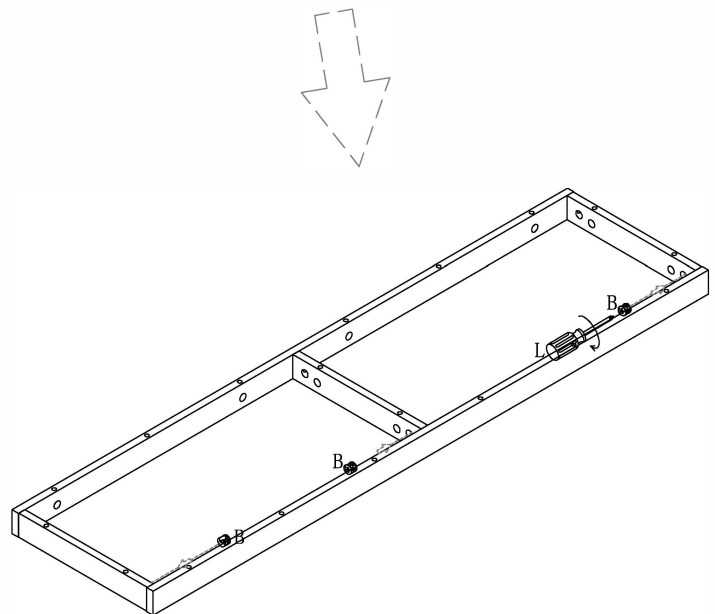
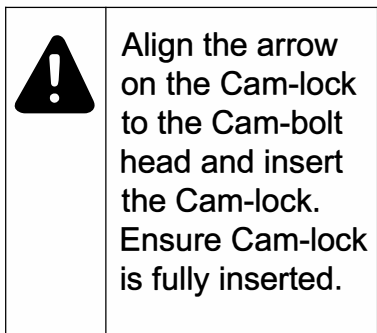
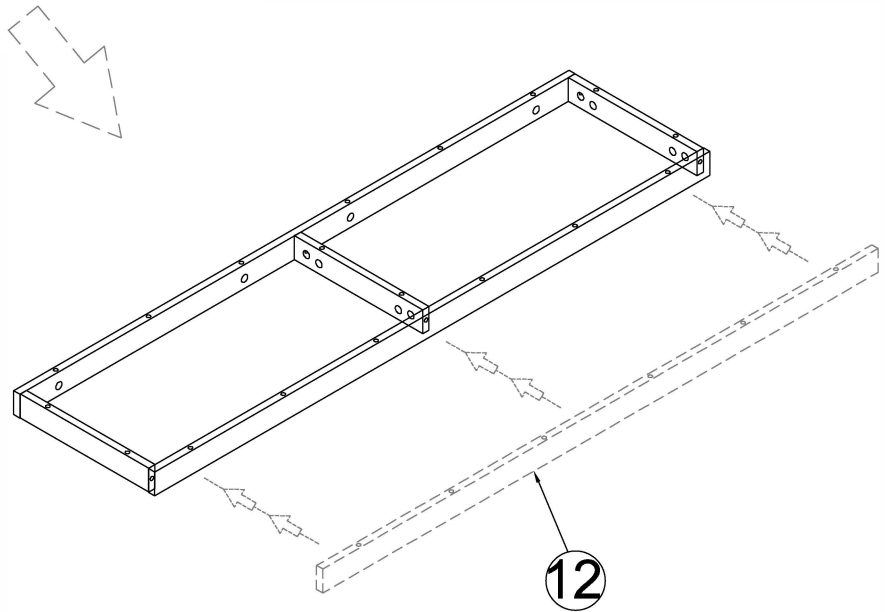
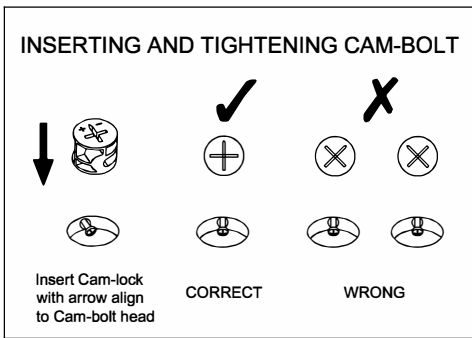
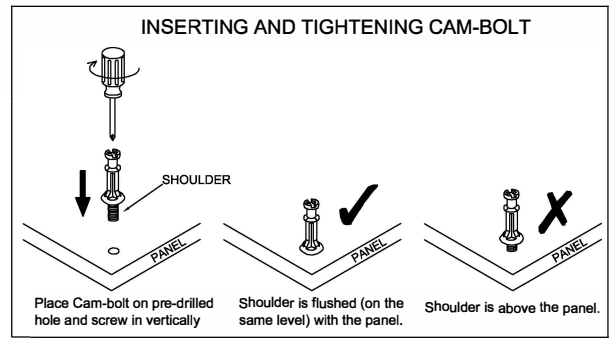
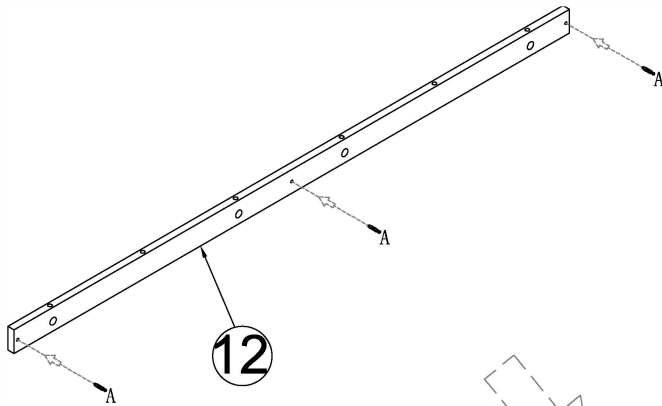

	A×3PCS
	B×3PCS

STEP 13

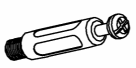

	A×3PCS
	B×3PCS

STEP 14

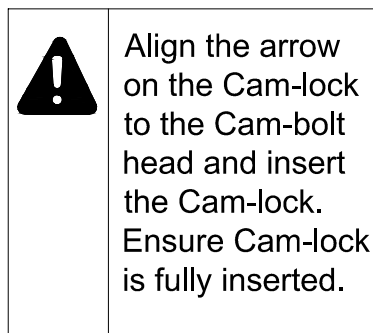
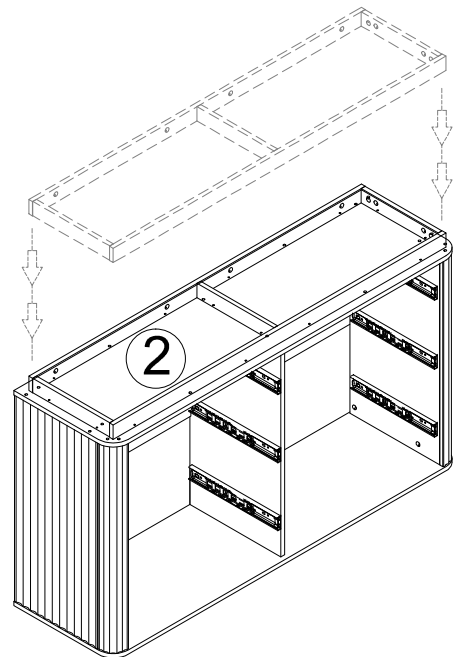
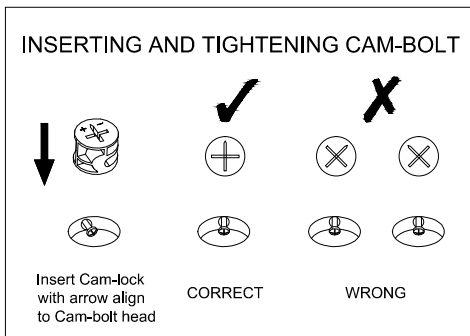
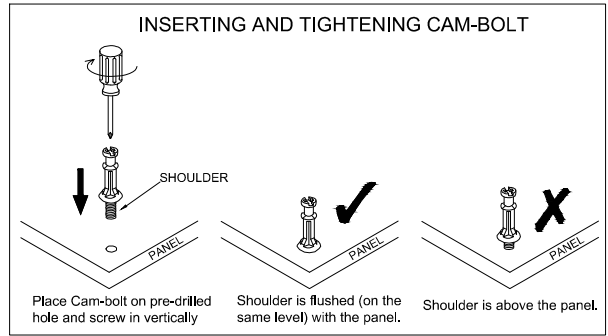
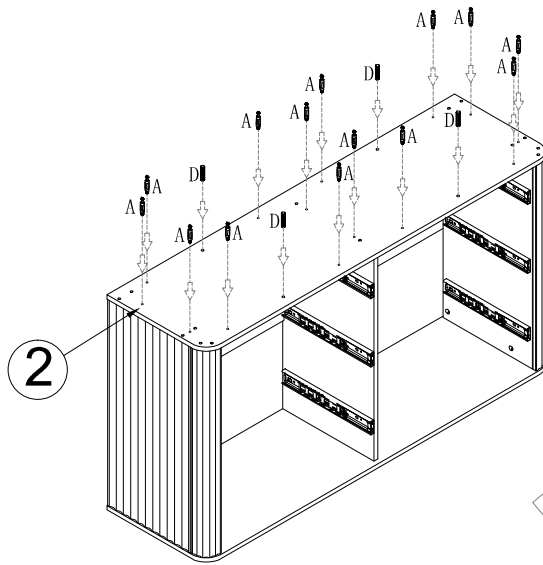

	A × 14PCS
	B × 14PCS
	D × 4PCS

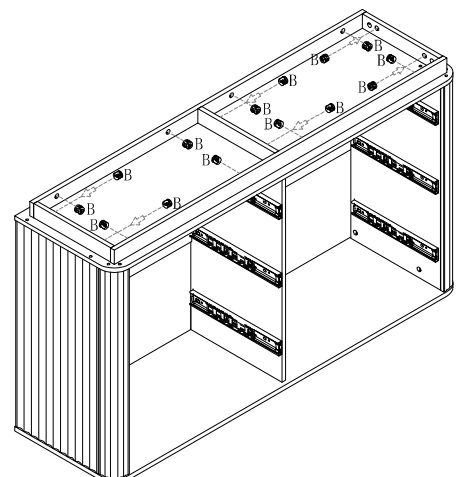

STEP 15

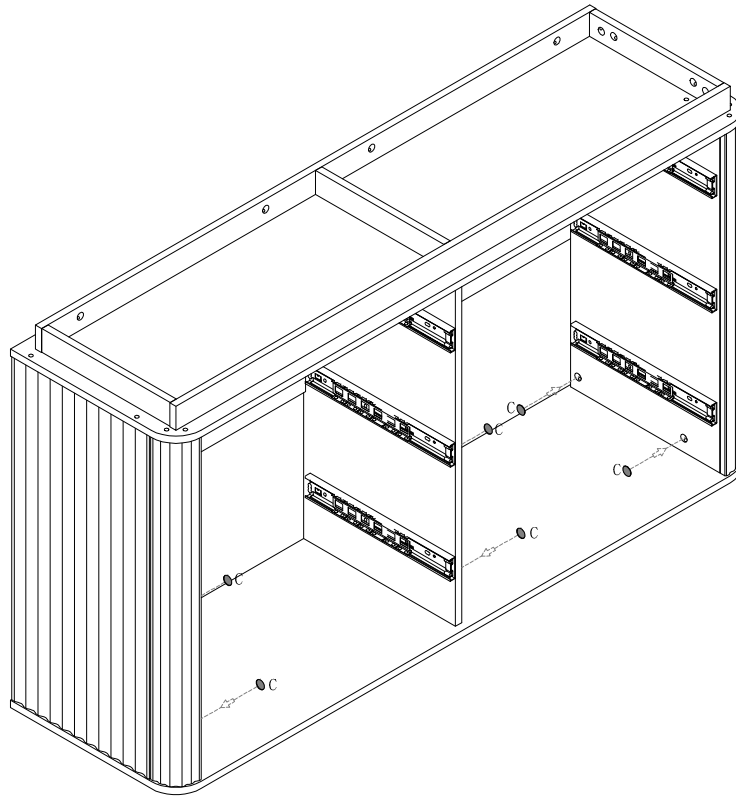

STEP 16

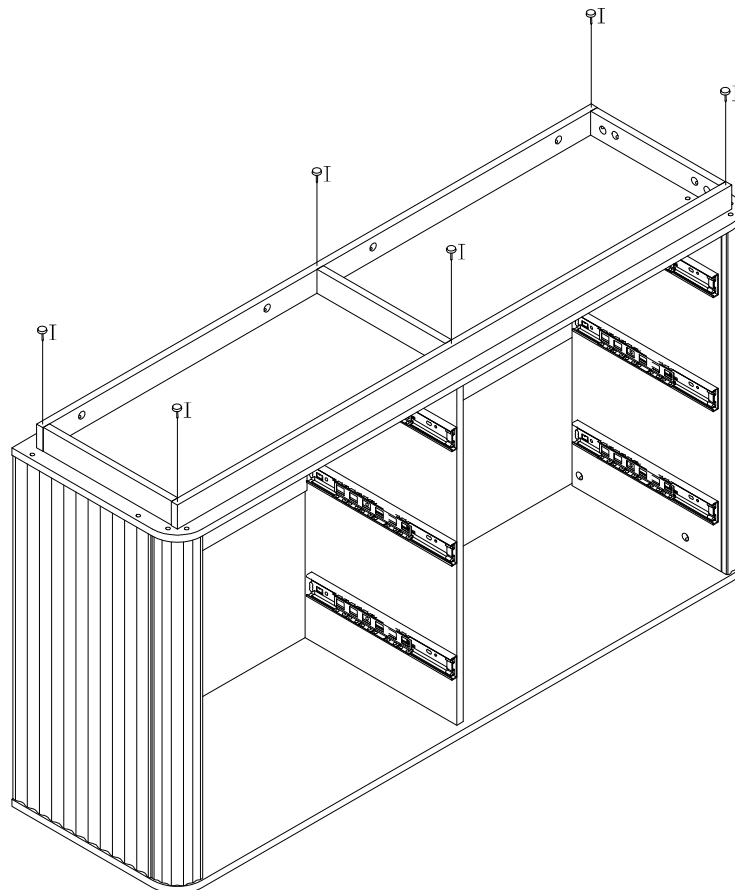

STEP 17

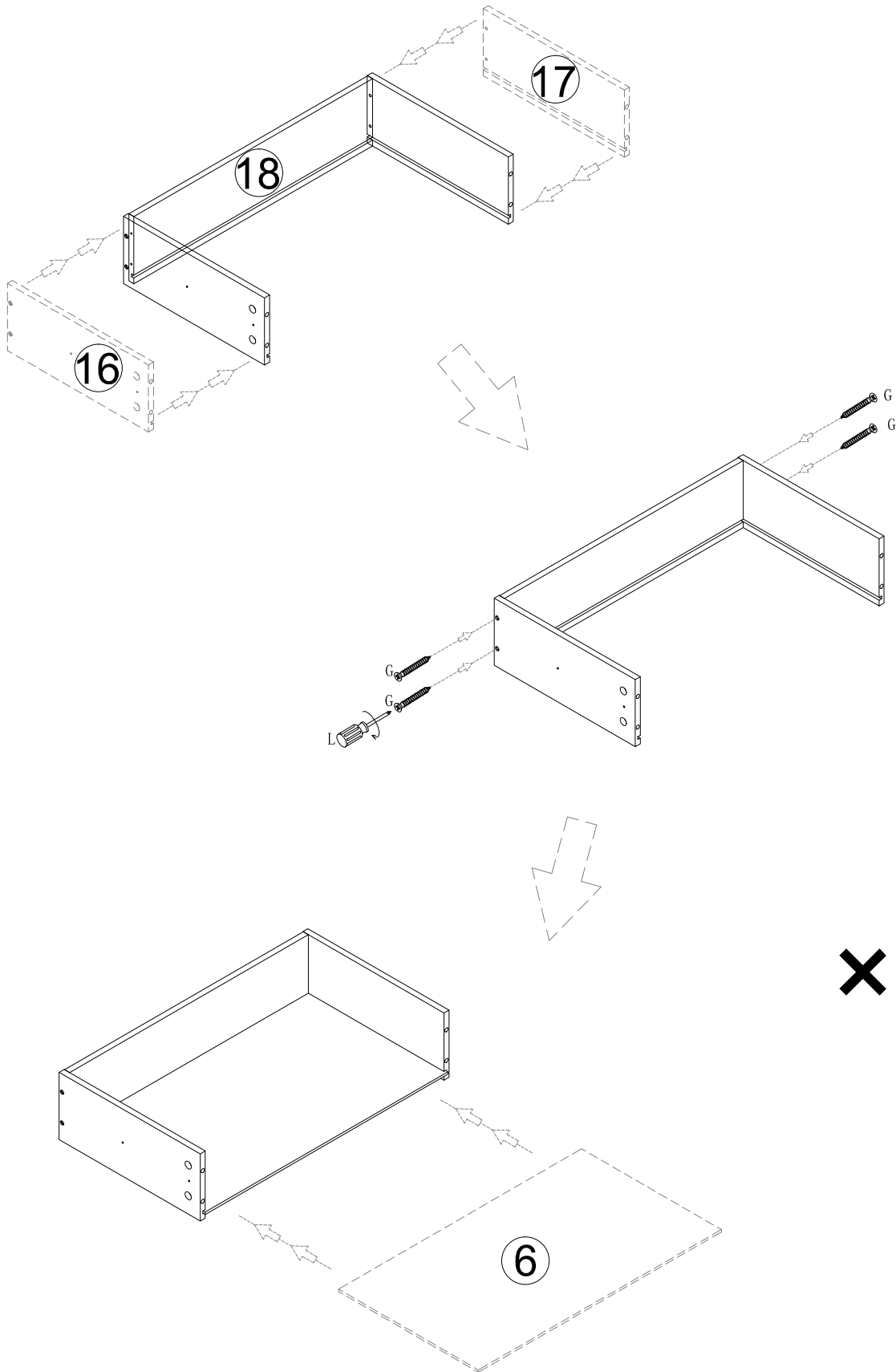

x6



STEP 18

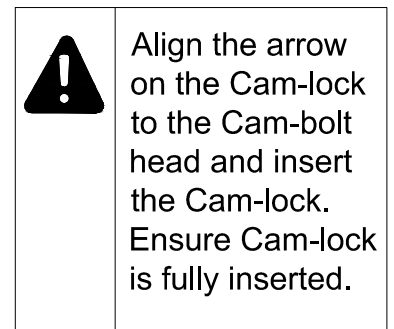
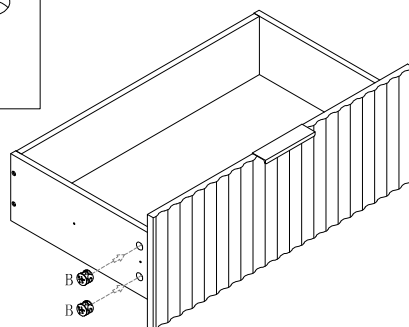
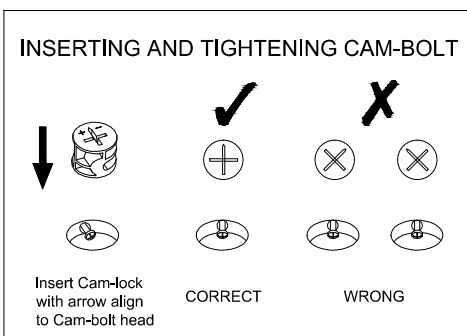
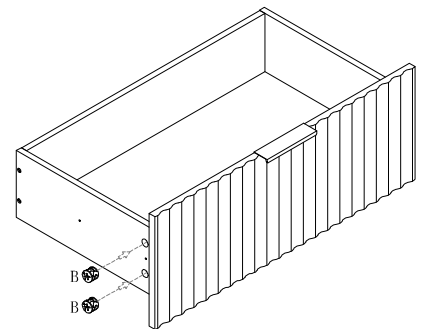
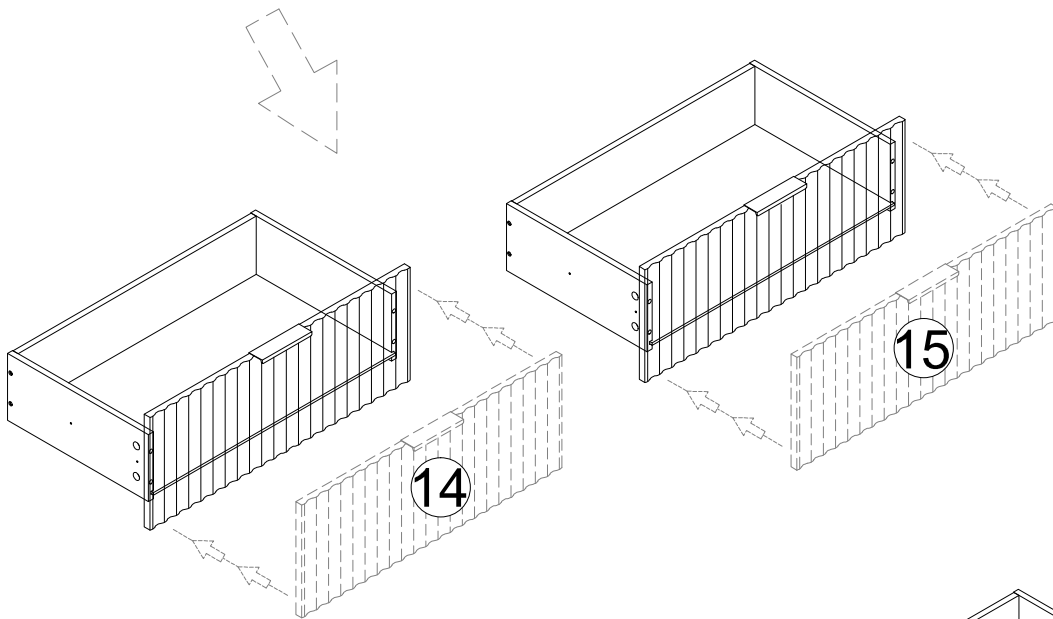
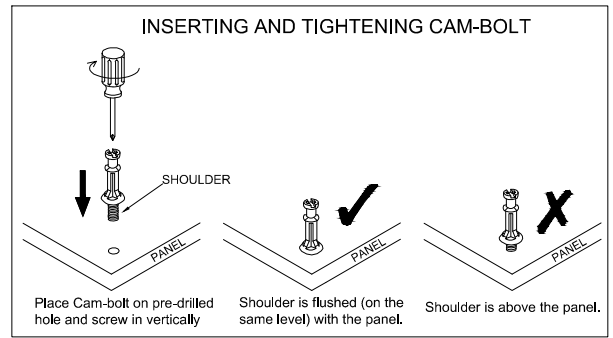
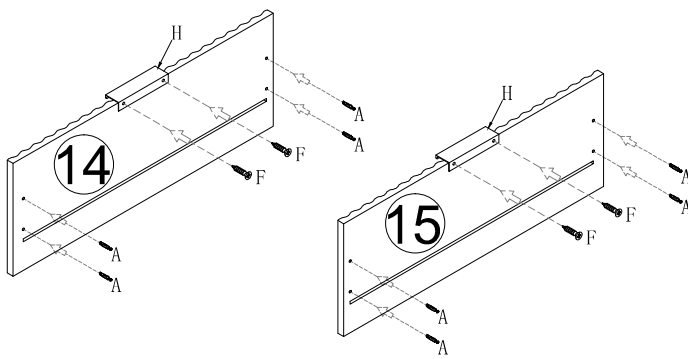

	A×24PCS
	B×24PCS
	F×12PCS
	H×6PCS

×3

STEP 19

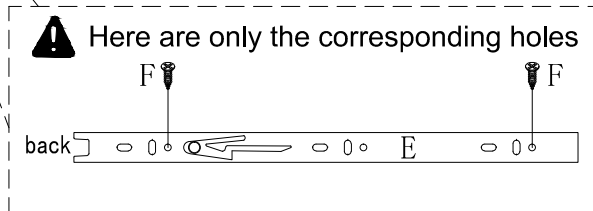
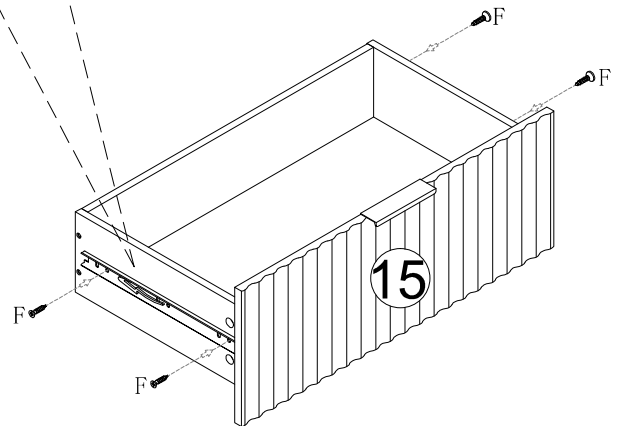
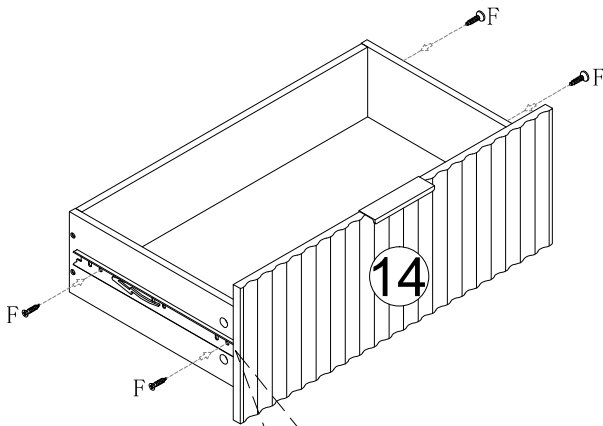
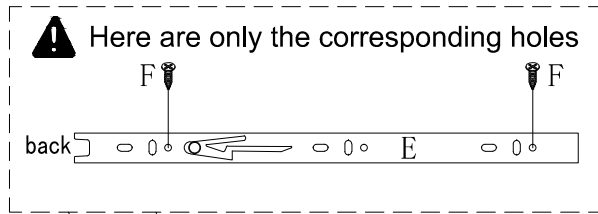

× 3



STEP 20

Drawer Front Alignment

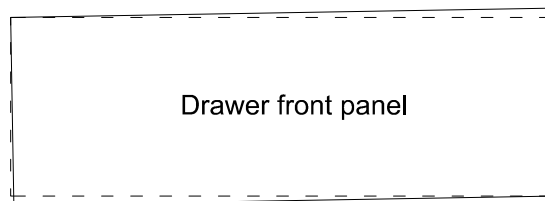

If the drawer front panel is NOT level after being assembled, then...

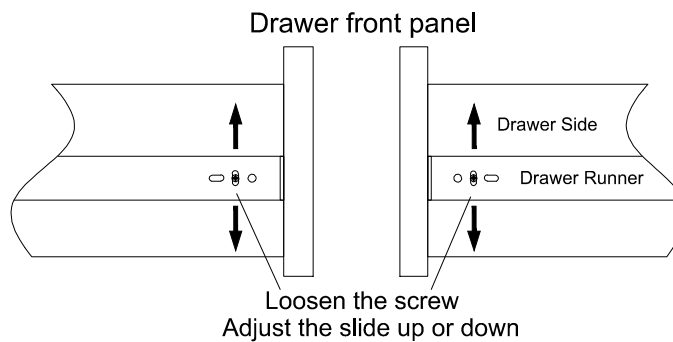

Loosen the screws on the left and right hand side, then adjust the drawer slide up or down, until the drawer fronts are even/level, then tighten the screws.

STEP 21

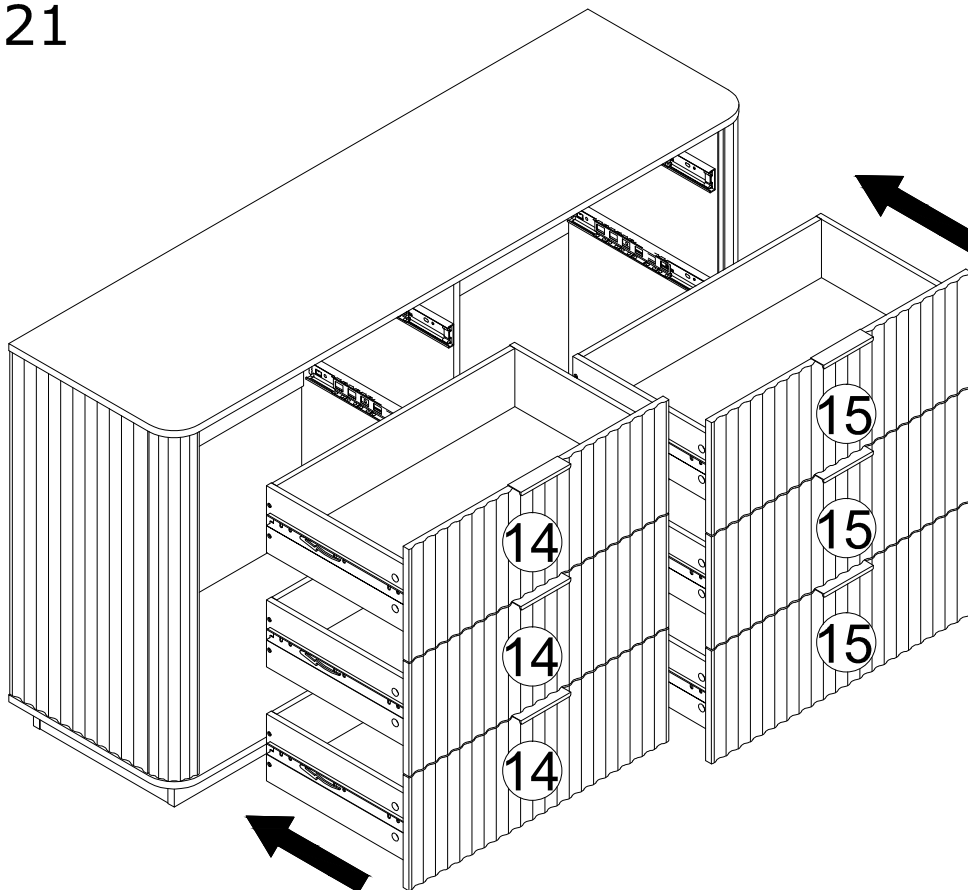

STEP 22

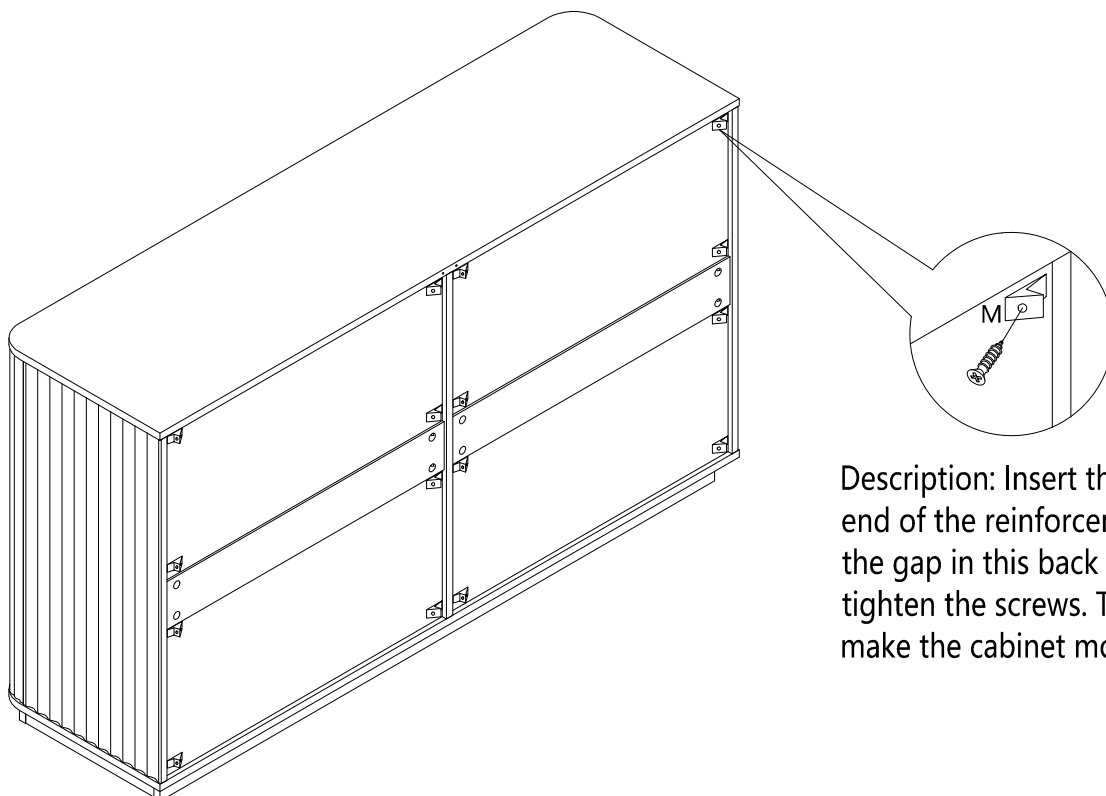

Description: Insert the thinner end of the reinforcement into the gap in this back panel, then tighten the screws. This will make the cabinet more stable.



STEP 23

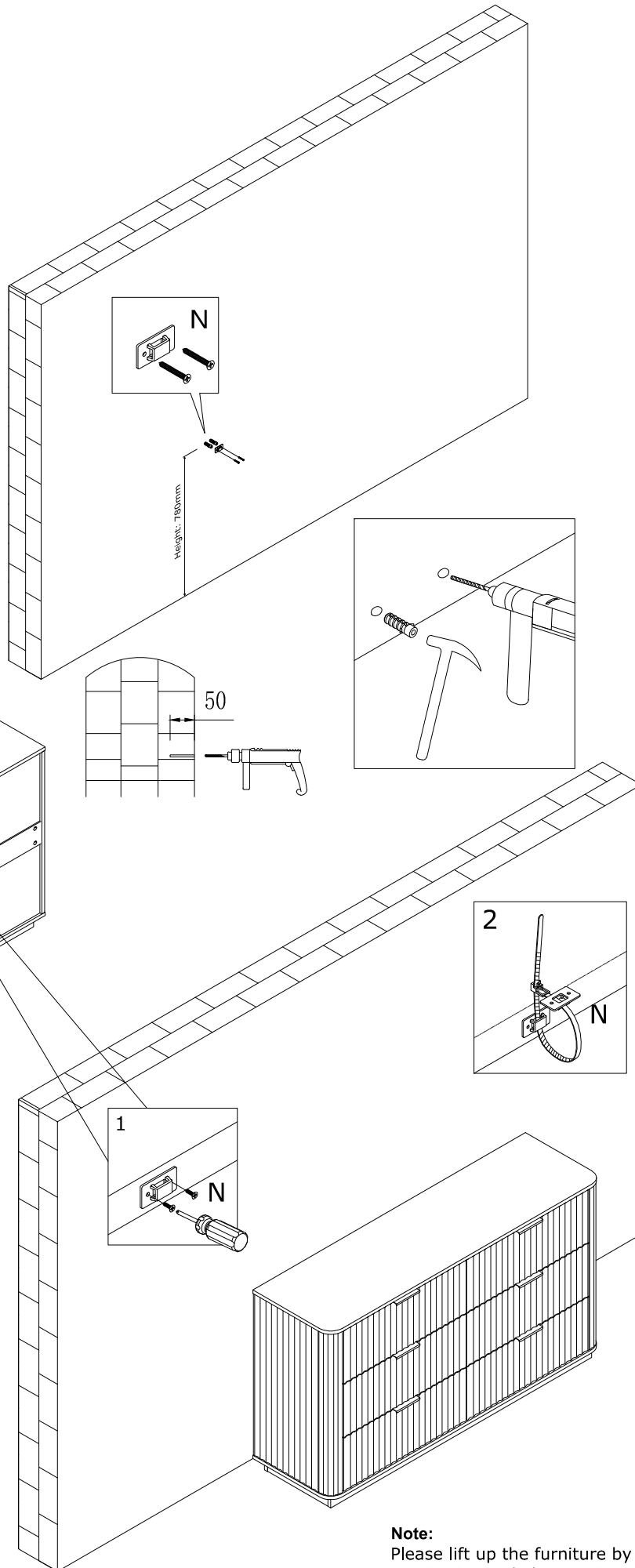

	N×1Sets
--	---------

Note:
Please lift up the furniture by two people when moving is needed. Dragging may cause the legs failure.