

ASSEMBLY INSTRUCTION/ INSTRUCTION DE MONTAGE

RATTAN SOFA SET/ SALON DE JARDIN

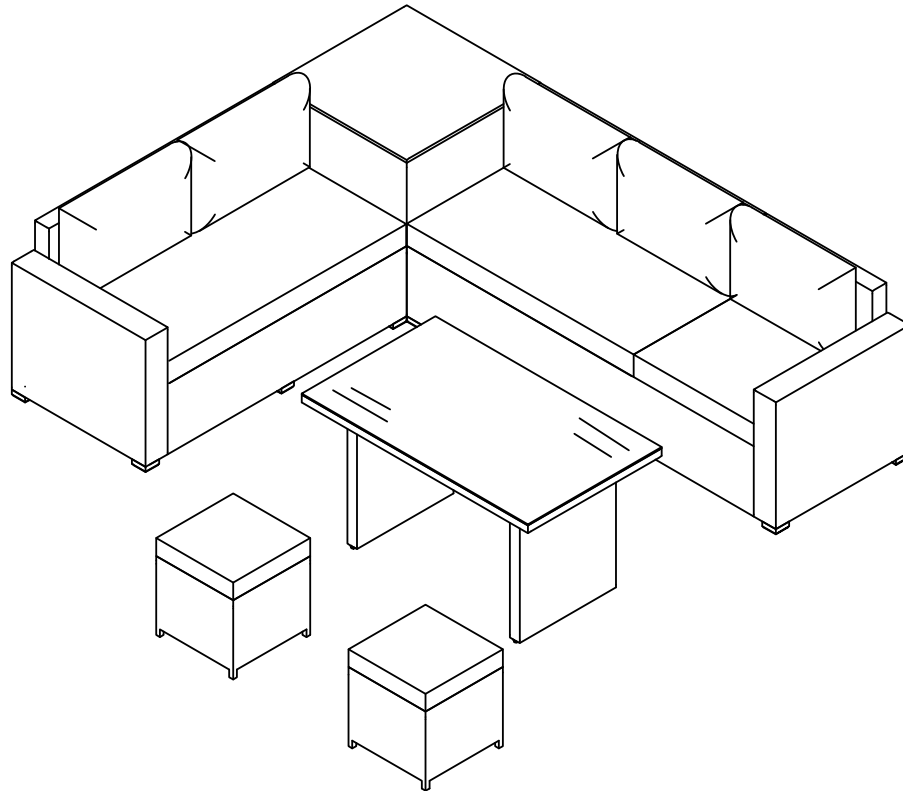

Notice/Avis

- 1. 50% Tighten before fixings all screws, Allen wrench is recommended instead of an electric drill./ Serrez à 50 % avant de fixer toutes les vis, Une clé Allen est recommandée plutôt qu'une perceuse électrique**
- 2. Place the item on a flat ground to adjust and make sure it remains stable./Placez l'objet sur un sol plat pour l'ajuster et assurez-vous qu'il reste stable.**
- 3. Tighten up all screws with tools gradually./ Serrez progressivement toutes les vis avec des outils.**

4. If the screws are not aligned with holes during assembly, please loosen all the other screws to 50% and continue the assembly process./

Si les vis ne sont pas alignées avec les trous pendant l'assemblage, desserrez toutes les autres vis à 50 % et poursuivez le processus d'assemblage.

5. If the item is not stable, please loosen all the screws, adjust it on a flat ground and tighten up all screws again./

Si l'article n'est pas stable, desserrez toutes les vis, ajustez-le sur un sol plat et resserrez toutes les vis.

6. Note: If one or more screws are fully tightened during assembly, chances are the others will not be aligned with holes. In addition, all the holes are designed to be relatively larger to provide more space for the adjustment of the screws./

Remarque : si une ou plusieurs vis sont serrées à fond pendant l'assemblage, il est probable que les autres ne soient pas alignées avec les trous. De plus, tous les trous sont conçus pour être relativement plus grands afin de fournir plus d'espace pour le réglage des vis.

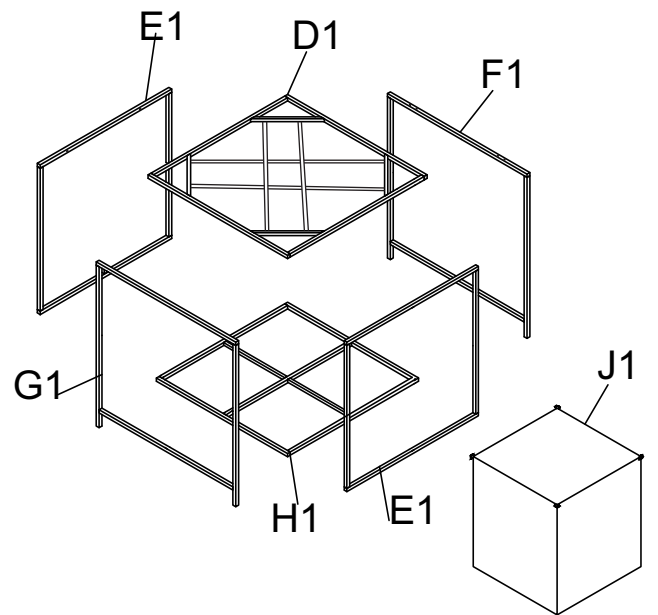
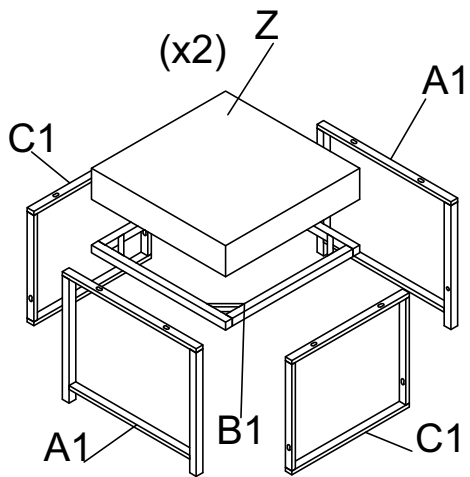
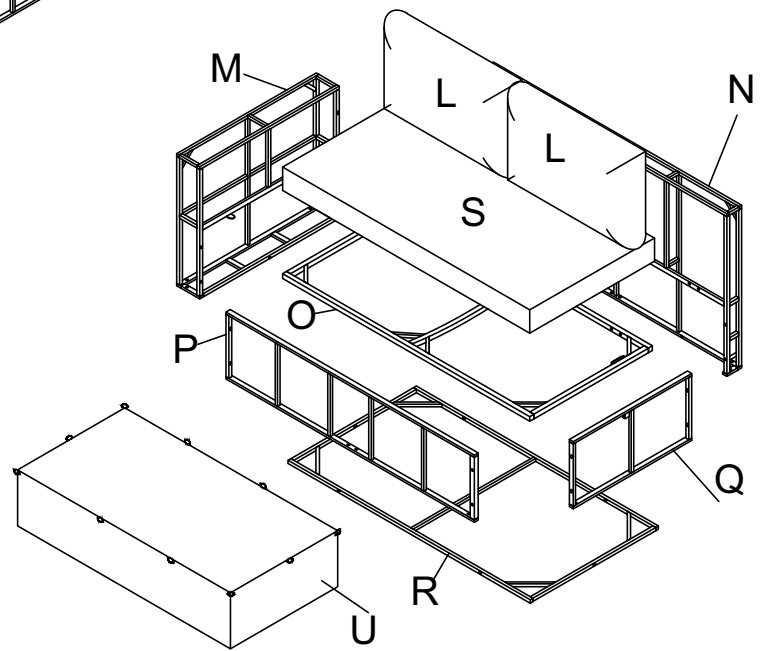
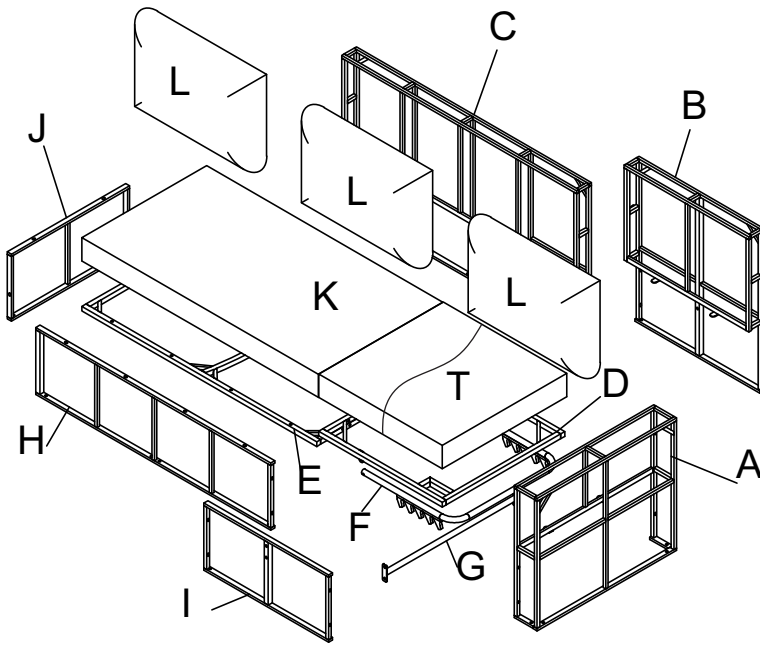

PART LIST/LISTE DES PIÈCES

A

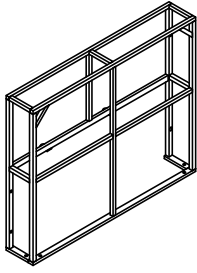

1 pc

B

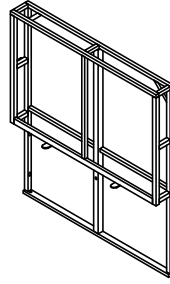

1 pc

C

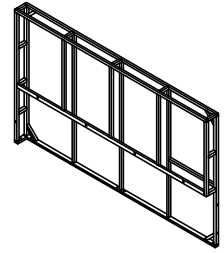

1 pc

D

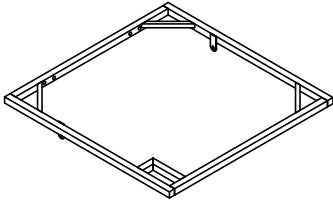

1 pc

E

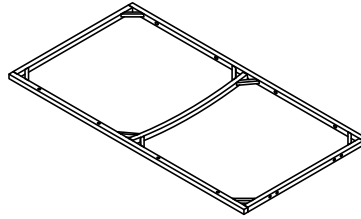

1 pc

F

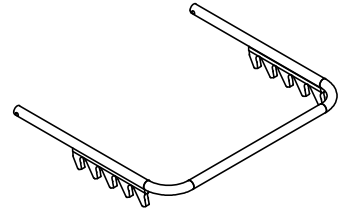

1 pc

G

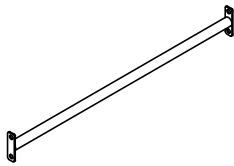

1 pc

H

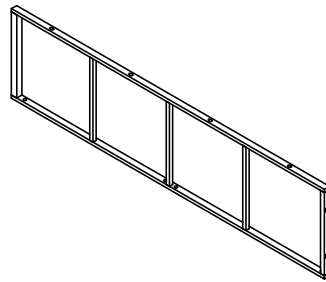

1 pc

I

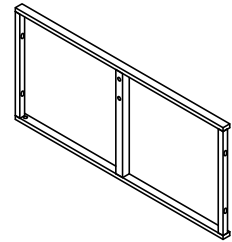

1 pc

J

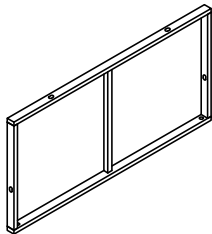

1 pc

K

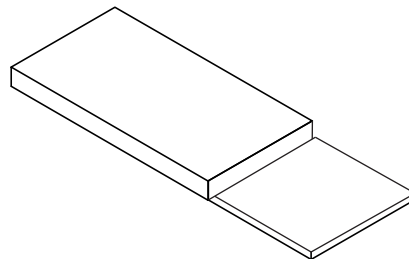

1 pc

L

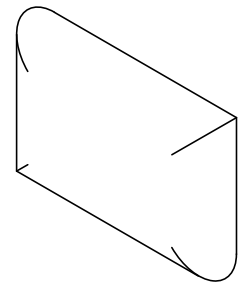

5 pcs

M

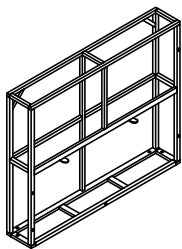

1 pc

N

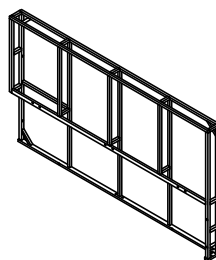

1 pc

O

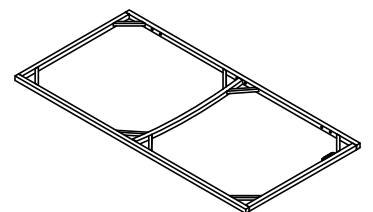

P

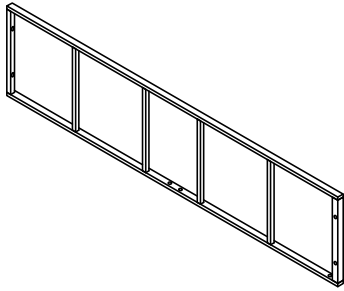

1 pc

Q

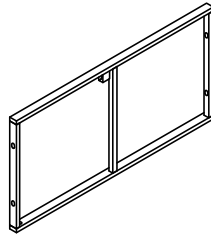

1 pc

R

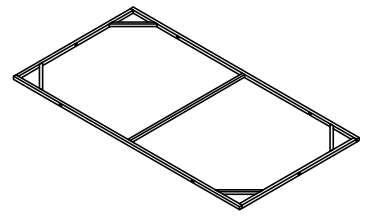

1 pc

S

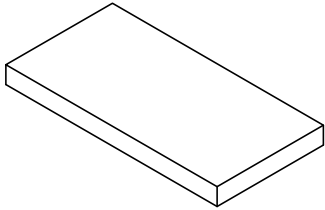

1 pc

T

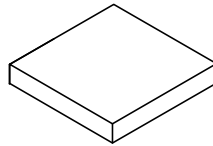

1 pc

U

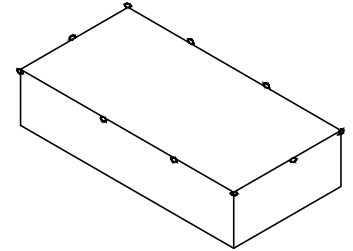

1 pc

V

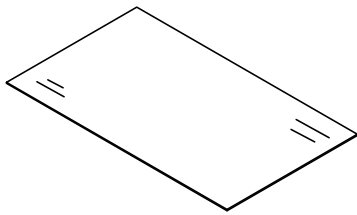

1 pc

W

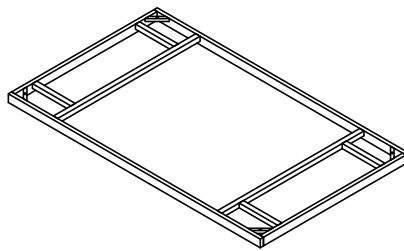

1 pc

X

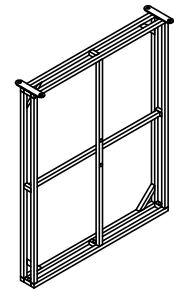

2 pcs

Y

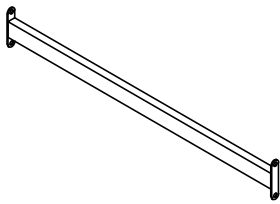

1 pc

Z

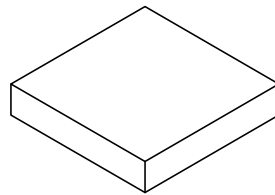

2 pcs

A1

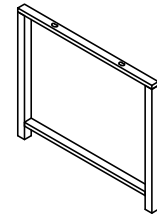

4 pcs

B1

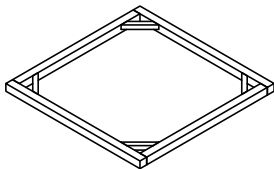

2 pcs

C1

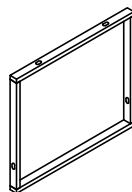





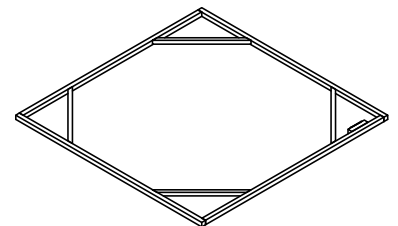

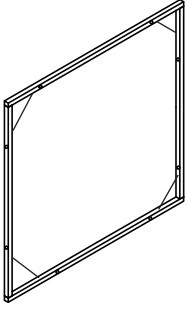
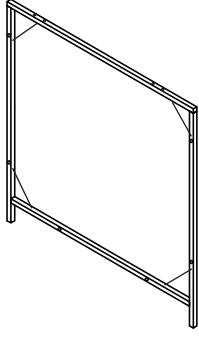
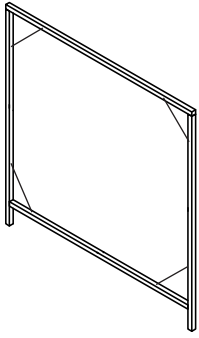
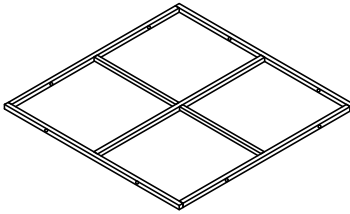
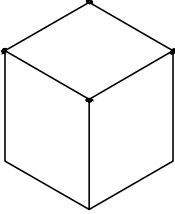
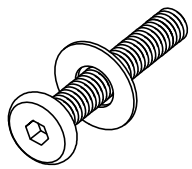
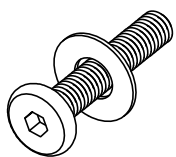
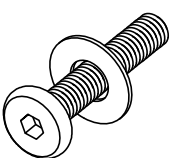
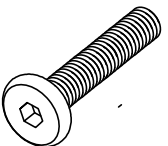

4 pcs

D1

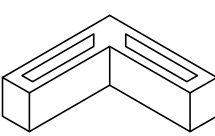
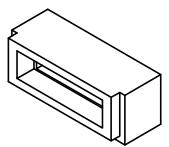

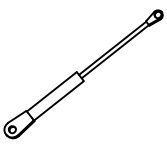
1 pc

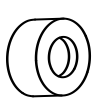
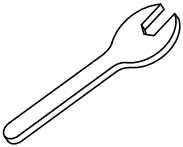
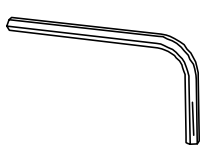
<p>E1</p>  <p>2 pcs</p>	<p>F1</p>  <p>1 pc</p>	<p>G1</p>  <p>1 pc</p>			
<p>H1</p>  <p>1 pc</p>		<p>J1</p>  <p>1 pc</p>			
<p>1</p>  <p>Bolt M6x35 mm/ Boulon M6x35 mm (2 pcs)+extra 1 pc</p>	<p>2</p>  <p>Bolt M6x40 mm/ Boulon M6x40 mm (12 pcs)+extra 1 pc</p>	<p>3</p>  <p>Bolt M6x30 mm/ Boulon M6x30 mm (63 pcs)+extra 3 pcs</p>	<p>4</p>  <p>Bolt M6x30 mm/ Boulon M6x30 mm (28 pcs)</p>	<p>5</p>  <p>Bolt M6x20mm Boulon M6x20 mm (16 pcs)+extra 2 pcs</p>	
<p>6</p>  <p>Bolt (thin ear) M6x20 mm Boulon (oreille fine) M6x20 mm (14 pcs)</p>	<p>7</p>  <p>Plastic washer M6x2mm Rondelle en plastique (2 pcs)+extra 1 pc</p>	<p>8</p>  <p>Nut M6 (2 pcs)+extra 1 pc</p>	<p>9</p>  <p>Plastic feet 1 Pieds en plastique 1 (8 pcs)</p>	<p>10</p>  <p>Plastic feet 2 Pieds en plastique 2 (6 pcs)</p>	
<p>11</p>  <p>Plastic feet Pieds en plastique (4 pcs)</p>	<p>12</p>  <p>Gas spring Vérin à gaz (2 pcs)</p>	<p>13</p>  <p>Bolt (thin ear) M6x25 mm Boulon (oreille fine) M6x25 mm (4 pcs)+extra 1 pc</p>	<p>14</p>  <p>Plastic washer M6x10mm Rondelle en plastique (4 pcs)+extra 1 pc</p>	<p>15</p>  <p>Spanner Clé à molette (1 pc)</p>	<p>16</p>  <p>Allen key M4 Clé à molette (2 pcs)</p>

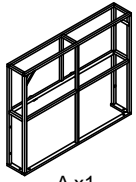

A x1

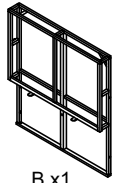

B x1

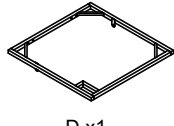

D x1

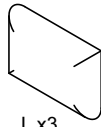

L x3

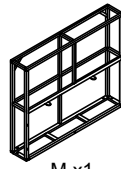

M x1

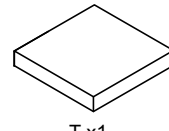

T x1

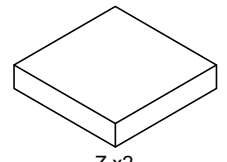

Z x2

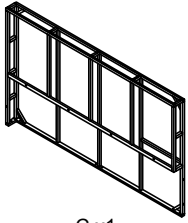

C x1

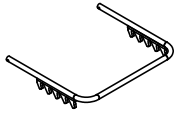

F x1

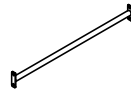

G x1

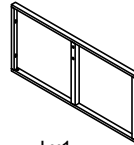

I x1

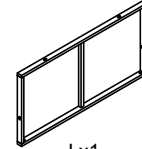

J x1

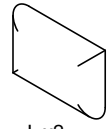

L x2

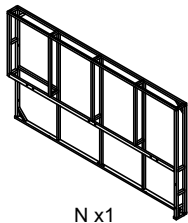

N x1

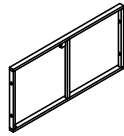

Q x1

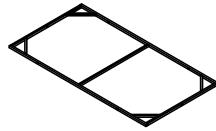

R x1

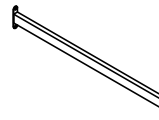

Y x1

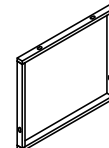

C1 x4



**HARDWARE/
MATÉRIEL**

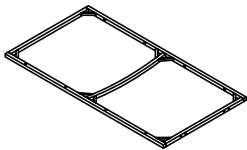

E x1

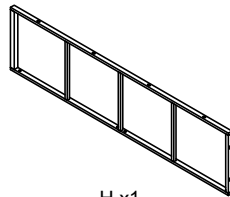

H x1

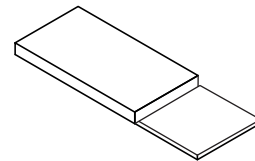

K x1

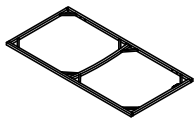

O x3

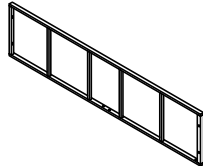

P x1

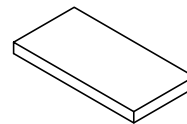

S x1

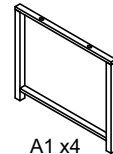

A1 x4

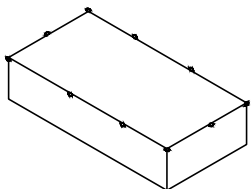

U x1

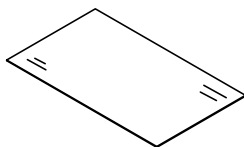

V x1

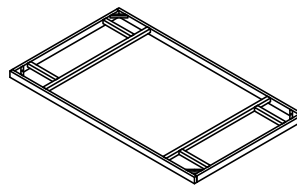

W x1

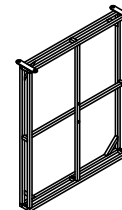

X x2

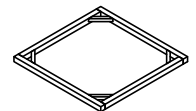

B1 x1

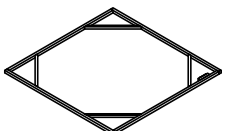

D1 x1

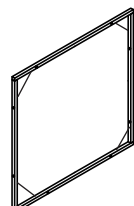

E1 x2

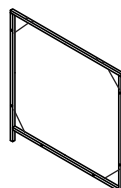

F1 x1

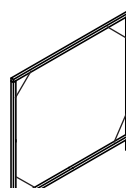

G1 x1

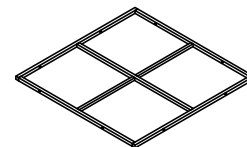

H1 x1

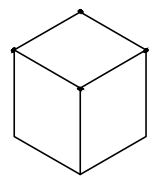

J1 x1

Step 1/Étape 1

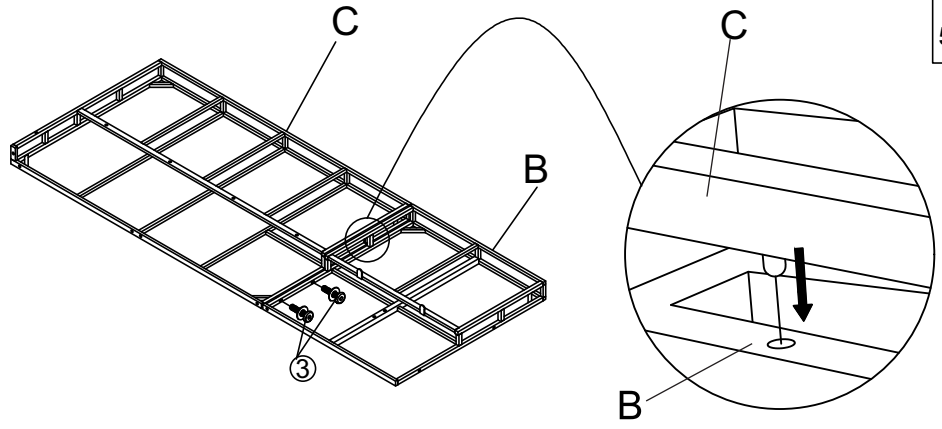

③ x2

Step 2/Étape 2

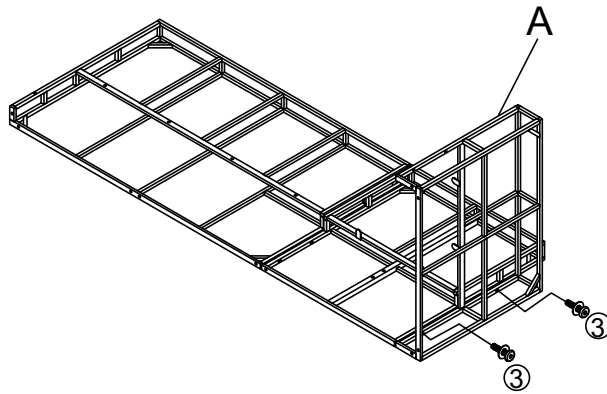

③ x2

Step 3/Étape 3

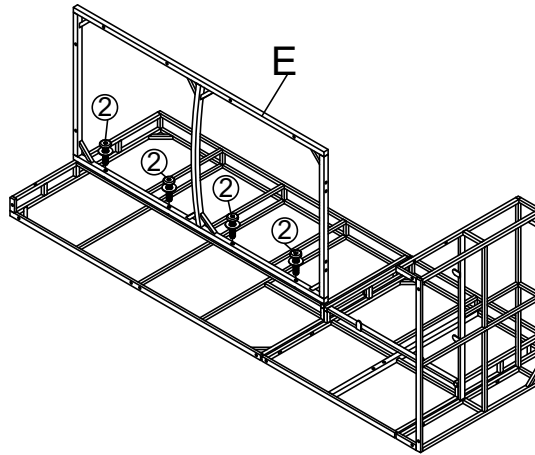

② x4

Step 4/Étape 4

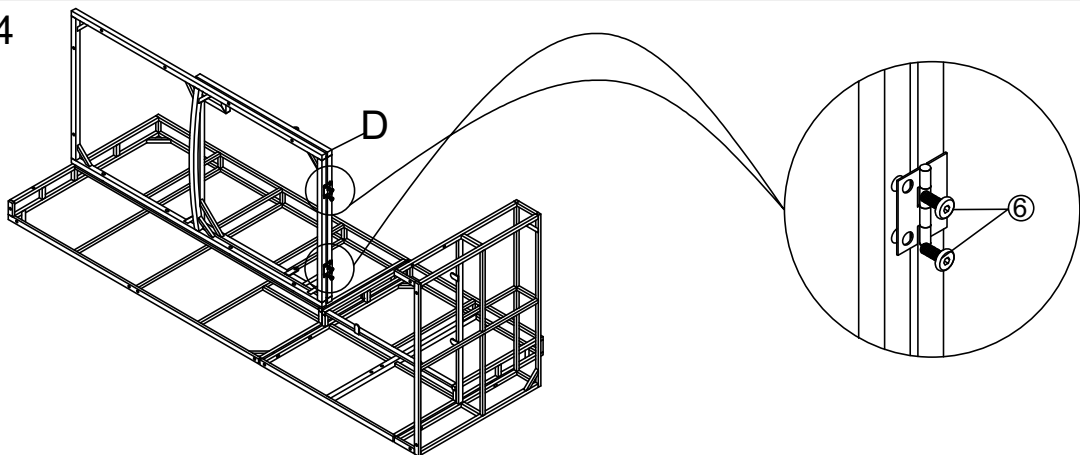

⑥ x4

Step 5/Étape 5

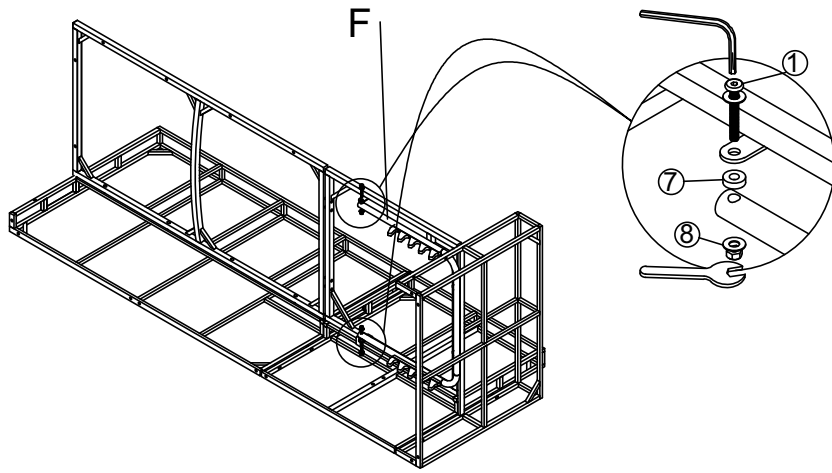

① x2 ⑦ x2 ⑧ x2

Step 6/Étape 6

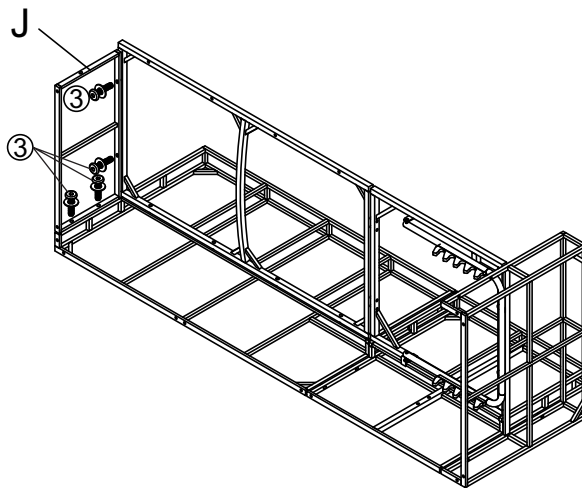

③ x4

Step 7/Étape 7

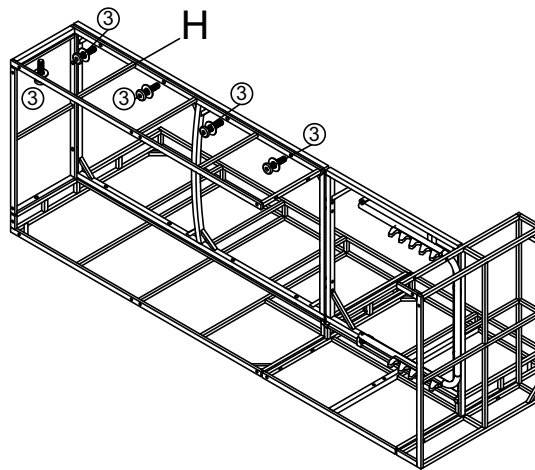

③ x5

Step 8/Étape 8

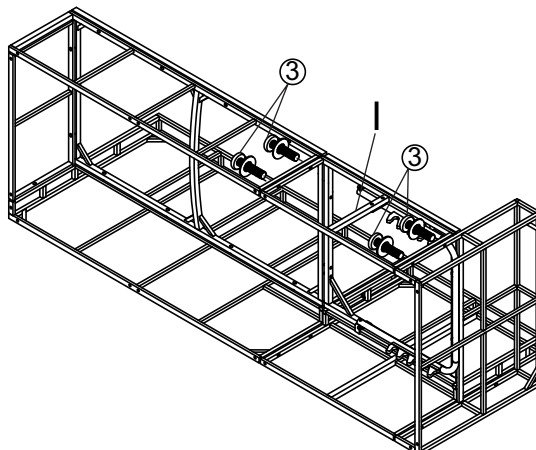

③ x4

Step 9/Étape 9

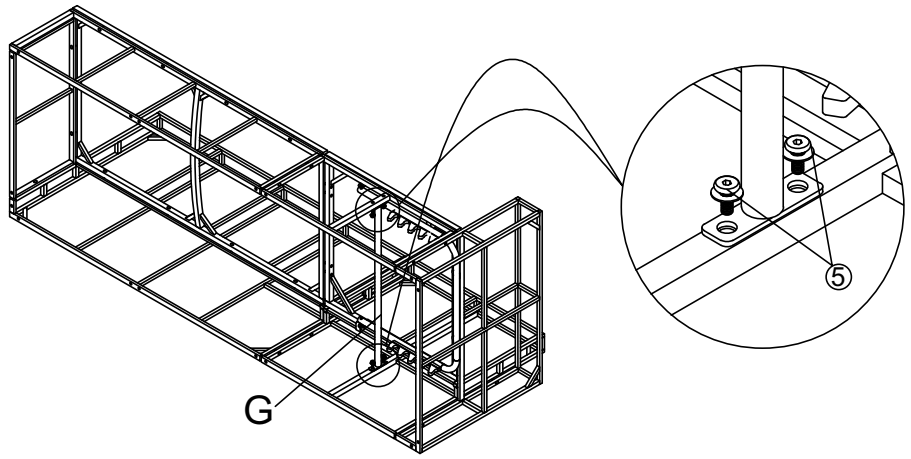

⑤ x4

Step 10/Étape 10

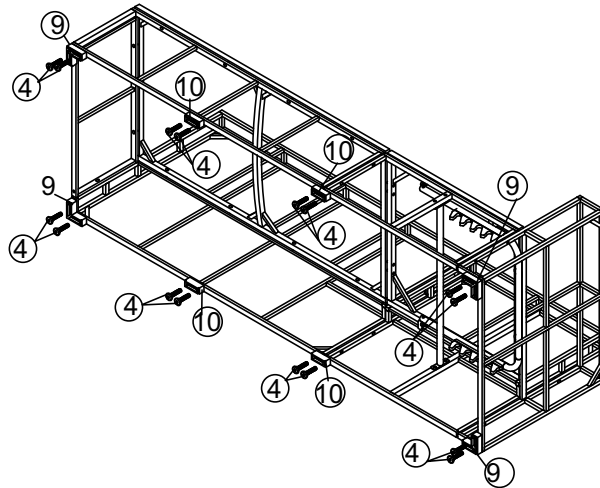

④ x16 ⑨ x4 ⑩ x4

Step 11/Étape 11

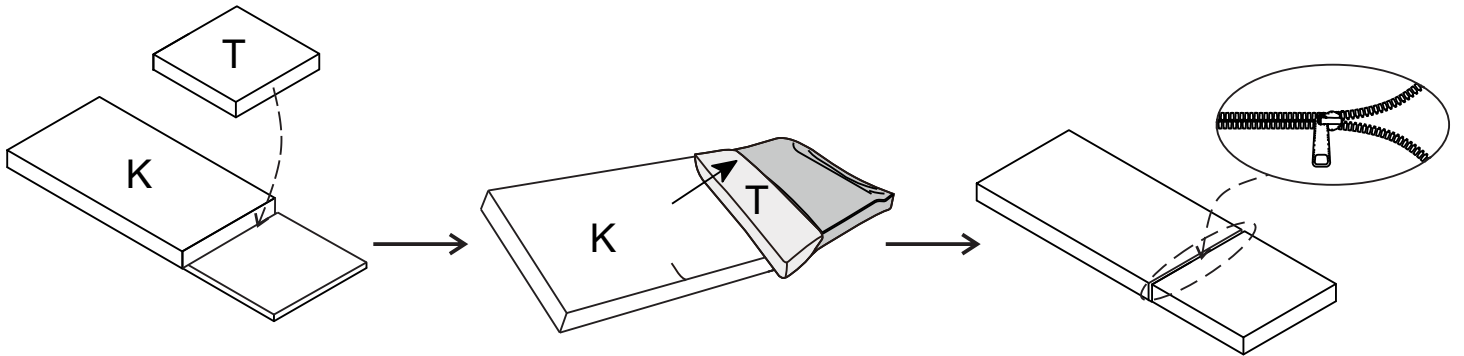

Step 12/Étape 12

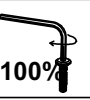
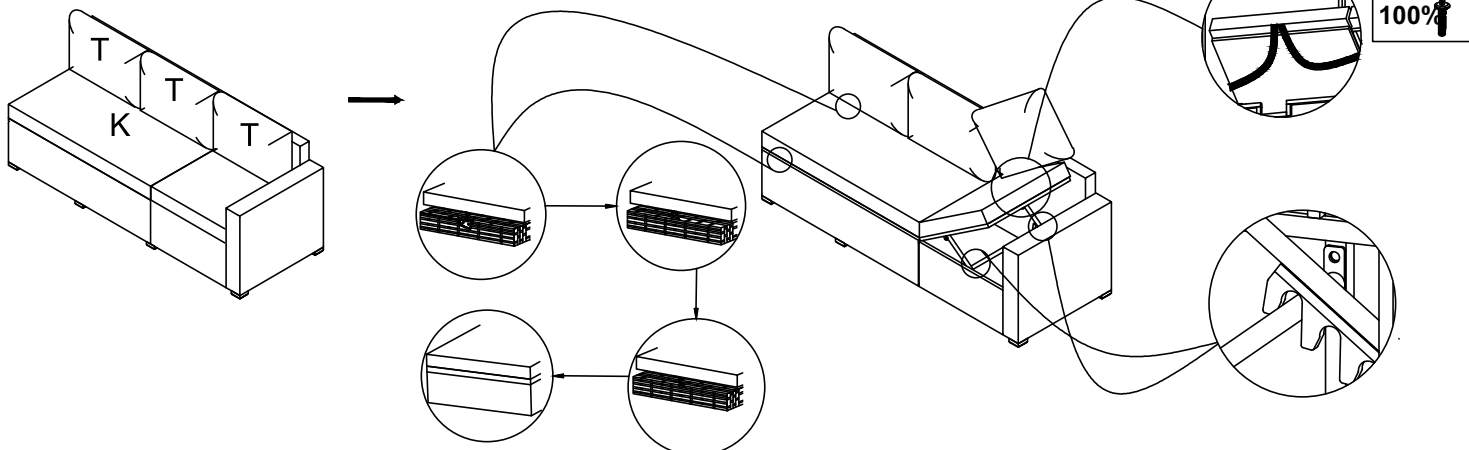

Step 13/Étape 13

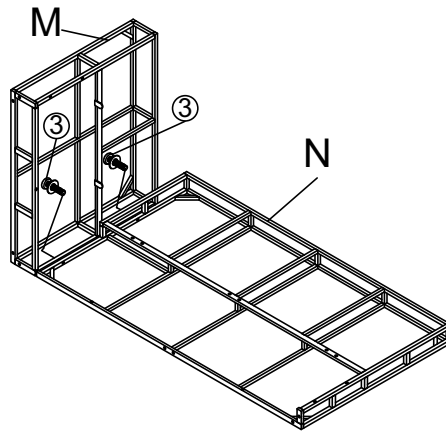

③ x2

Step 14/Étape 14

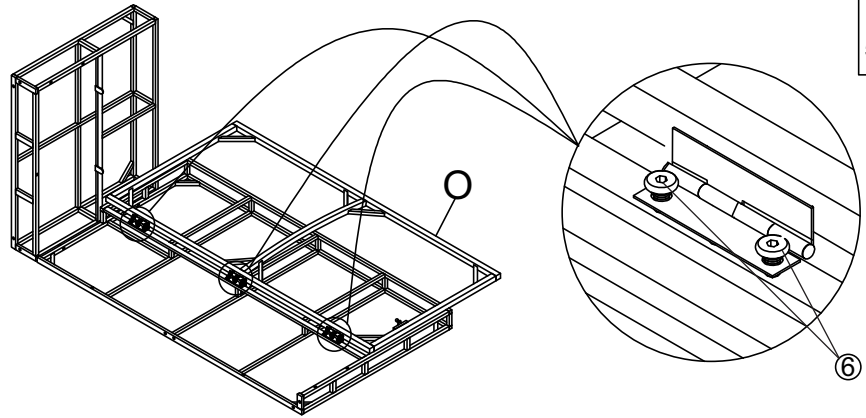

⑥ x6

Step 15/Étape 15

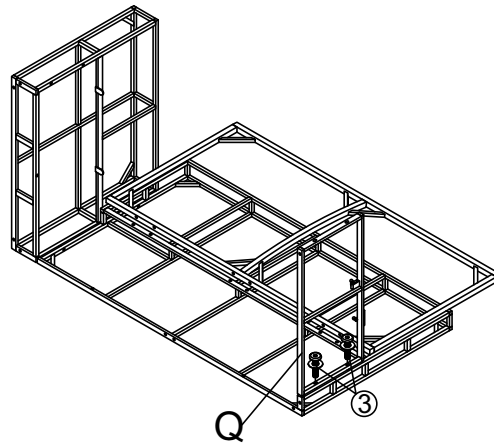

③ x2

Step 16/Étape 16

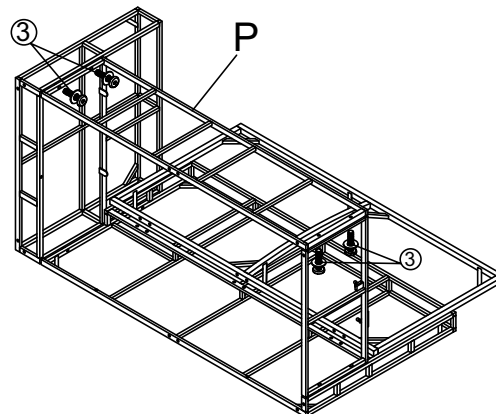

③ x4

Step 17/Étape 17

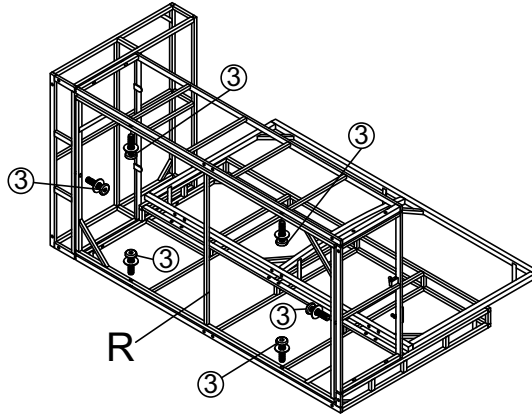

③ x6

Step 18/Étape 18

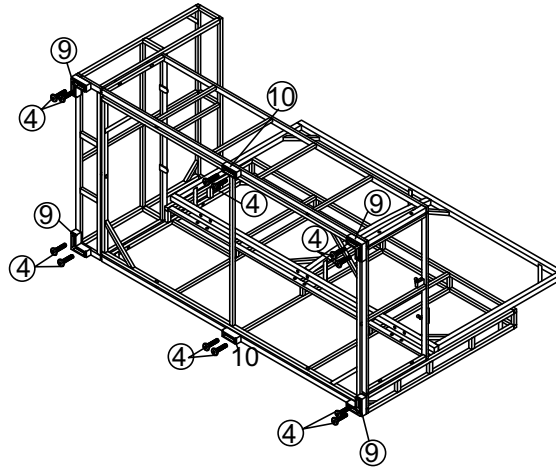

④ x12 ⑨ x4 ⑩ x2

Step 19/Étape 19

Always keep part O sheet upward like T not ⊥ and click gas spring with sheet/
Gardez toujours la feuille de la partie O vers le haut comme T et non ⊥ pas cliquez sur le ressort à gaz avec la feuille

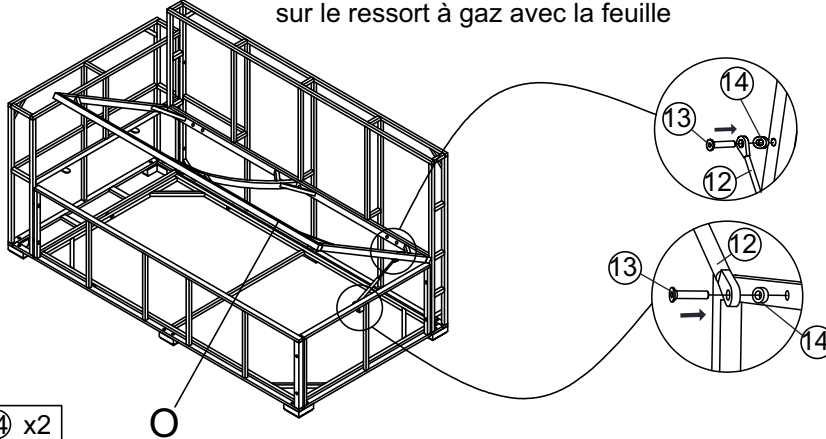

⑫ x1 ⑬ x2 ⑭ x2

Step 20/Étape 20

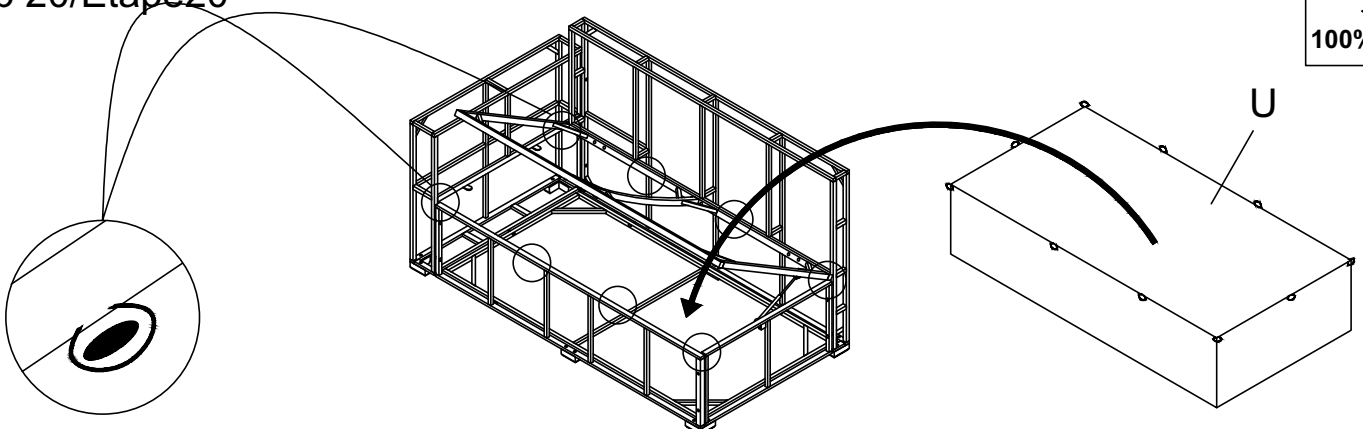

Step 21/Étape 21

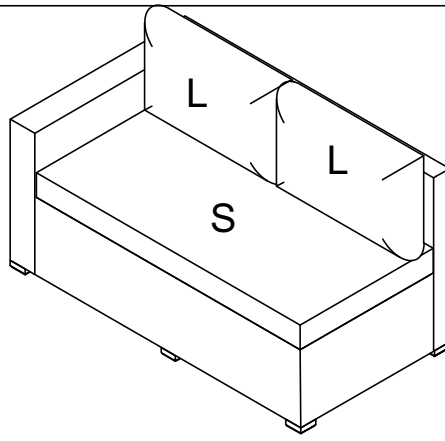

Step 22/Étape 22

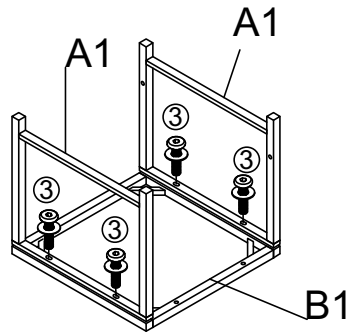

x2



③ x4

Step 23/Étape 23

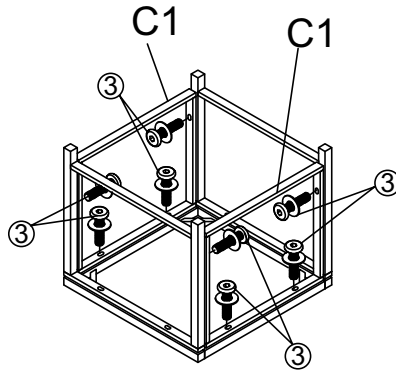

x2



③ x8

Step 24/Étape 24

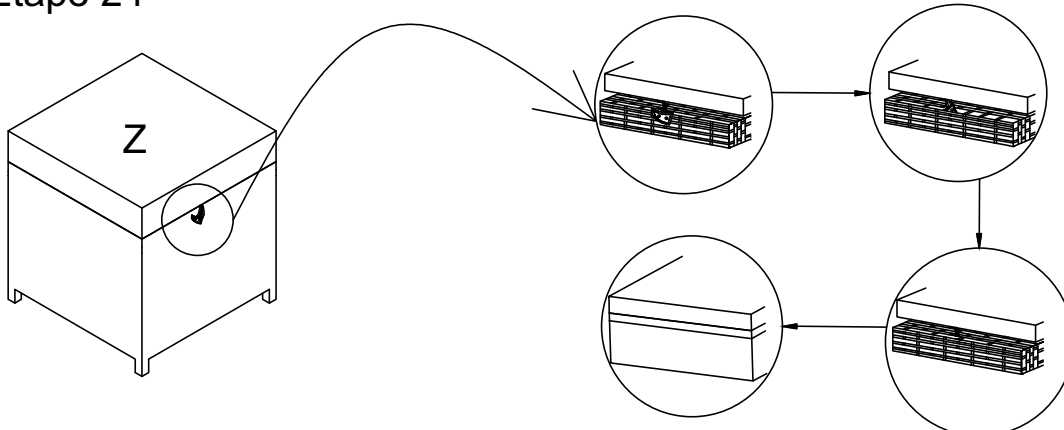

x2



Step 25/Étape 25

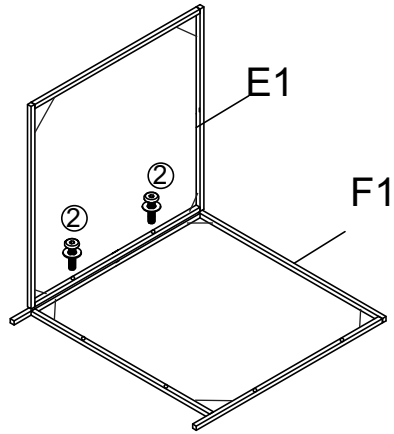

② x2

Step 26/Étape 26

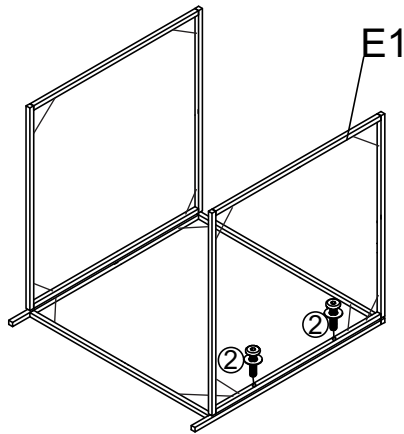

② x2

Step 27/Étape 27

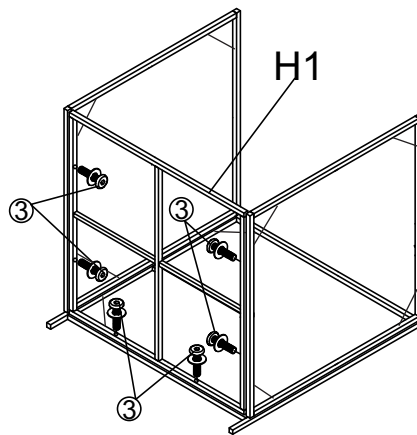

③ x6

Step 28/Étape 28

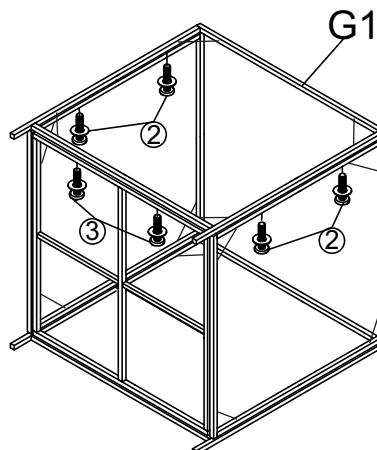

② x4 ③ x2

Step 29/Étape 29

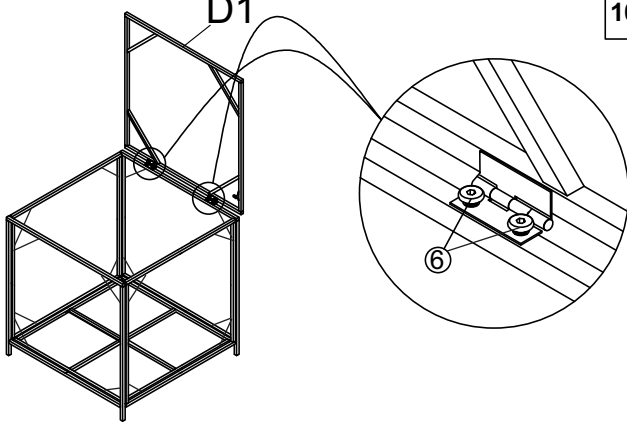

⑥ x4

Step 30/Étape 30

Always keep part D1 sheet upward like T not ⊥ and click gas spring with sheet/ Gardez toujours la partie O de la tôle vers le haut comme T et non ⊥ et cliquez le ressort à gaz avec la tôle

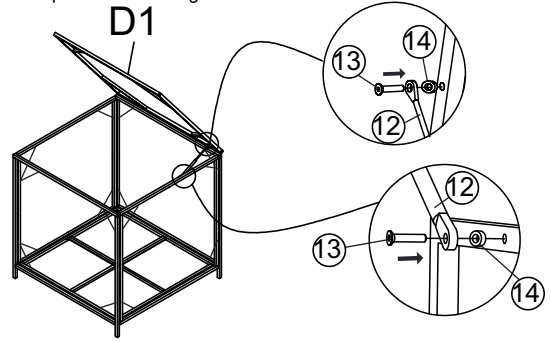

⑫ x1 ⑬ x2 ⑭ x2

Step 31/Étape 31

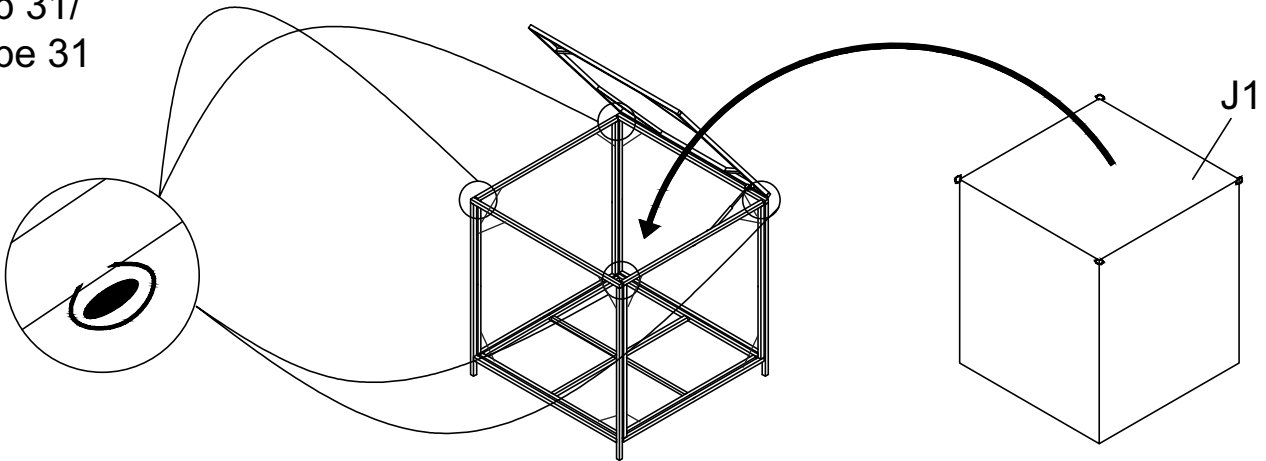

Step 32/Étape 32

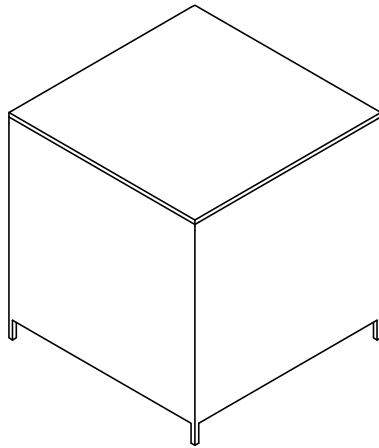

Step 33/Étape 33

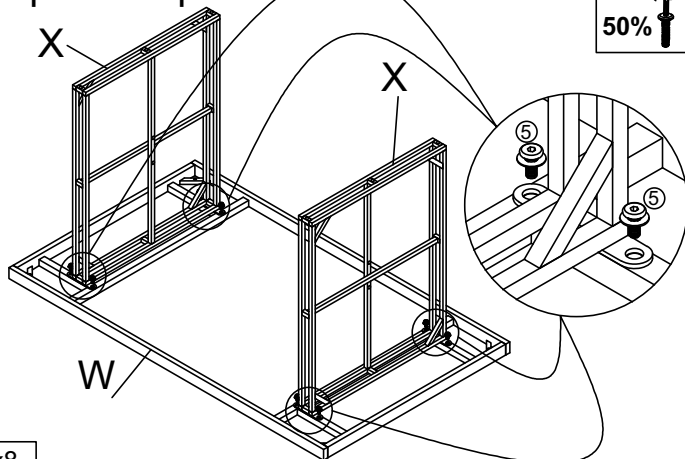

⑤ x8

Step 34/Étape 34

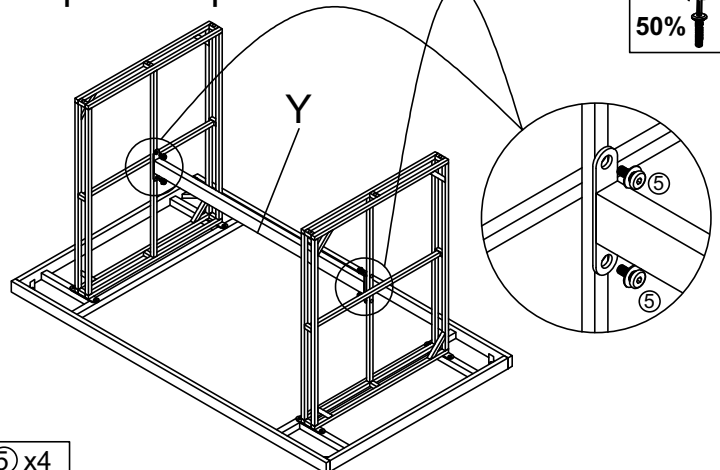

⑤ x4

Step 35/Étape 35

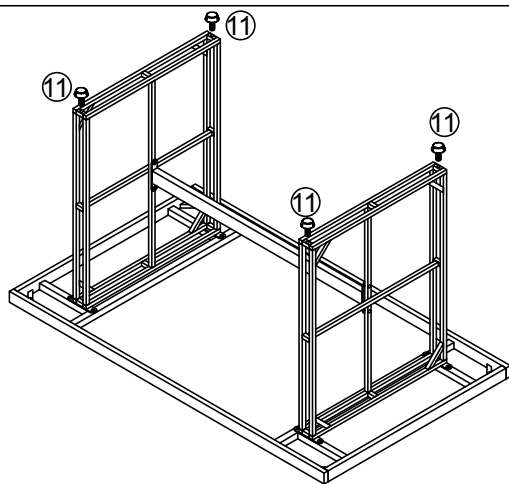

⑪ x6

Step 36/Étape 36

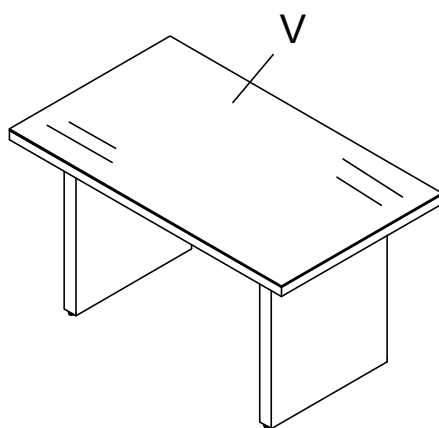

Step 37/Étape 37

