

USER MANUAL

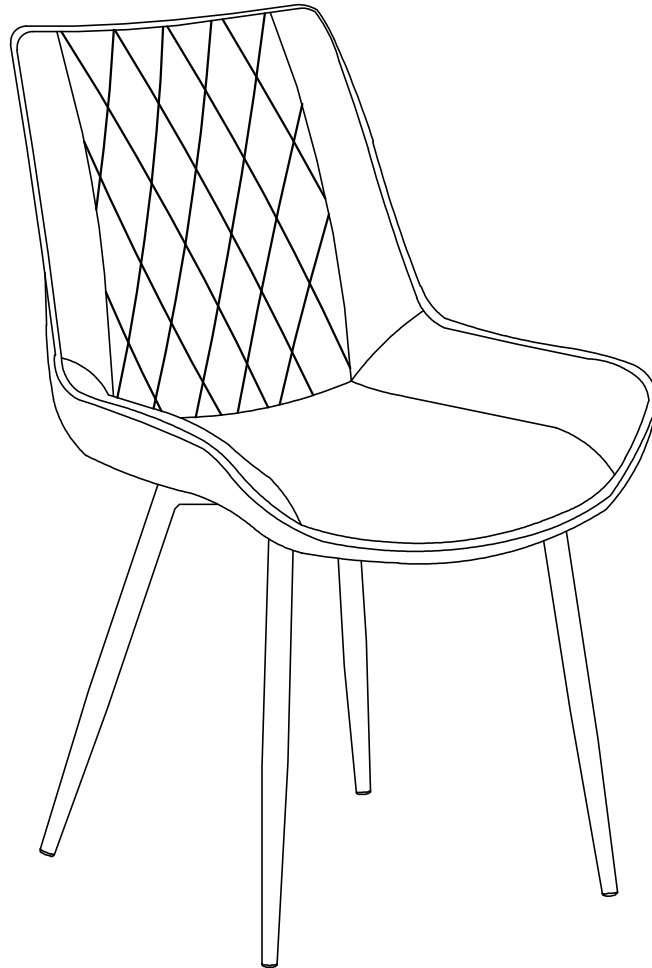

Retain these instructions for future reference.



Do not discard any of the packaging until you have checked that you have all the parts and the pack of fixings.

ASSEMBLY CHECKLIST



Read through the instructions carefully before you begin.

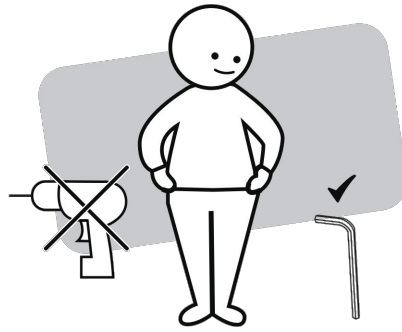

Make sure you have all the required tools. Never use power tools unless instructed.

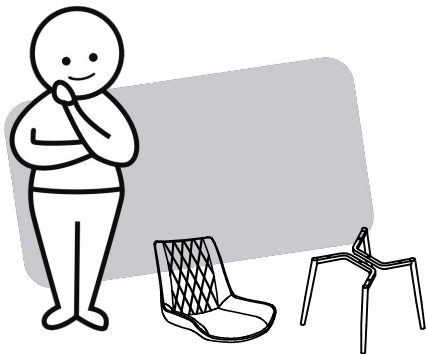

Identify and lay out all of the components before assembling.

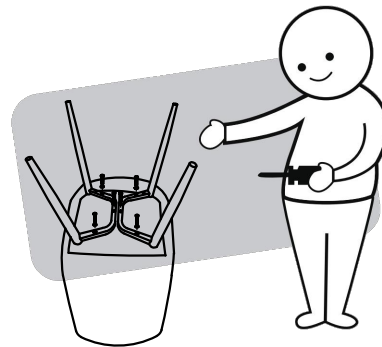

Unless instructed, do not fully tighten screws until the item is fully assembly.



WARNING! TO REDUCE THE RISK OF SERIOUS INJURY, READ THE FOLLOWING SAFETY INSTRUCTIONS BEFORE ASSEMBLING AND USING THE PRODUCT.

- Please read and understand this entire manual before attempting to assemble, operate, or install the product.
- Any assembly or maintenance of the product must be carried out by adults only.
- Some parts may contain sharp edges. Wear protective gloves if necessary.
- To prevent damage, place all parts on a level surface during assembly. Add a layer of protective surface if needed.
- Due to the nature of steel, surface oxidation (rusting) will occur if this protective coating is scratched. This is a natural process. To minimize this condition, it is recommended that care be taken when assembling and handling the product in order to prevent the paint from being scratched.

TOOLS REQUIRED

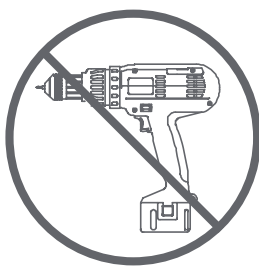

NOTE:

To avoid damage, ensure screws are hand tightened.

DO NOT USE POWER

TOOLS TO ASSEMBLE YOUR UNIT.



1 person

ASSEMBLY INSTRUCTIONS



ASSEMBLY TIPS:

1. Remove hardware from box and sort by size.
2. Please check to see that all hardware and parts are present prior to start of assembly.
3. Please follow attached instructions in the same sequence as numbered to assure fast & easy assembly.

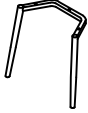

WARNING!

Don't attempt to repair or modify parts that are broken or defective. Please contact the seller immediately.

PARTS CHECKLIST

① SEAT AND BACK		2pcs
② LEFT LEGS		2pcs
③ RIGHT LEGS		2pcs

HARDWARE IDENTIFICATION

A	Bolt (M6x35mm)		12pcs
B	Washer (M6)		12pcs
C	Allen Key 5# (M6)		2pcs

ASSEMBLY INSTRUCTIONS

Step 1

Screw on bolts as shown in the picture, and tighten bolts with approximately **80%** of required torque.

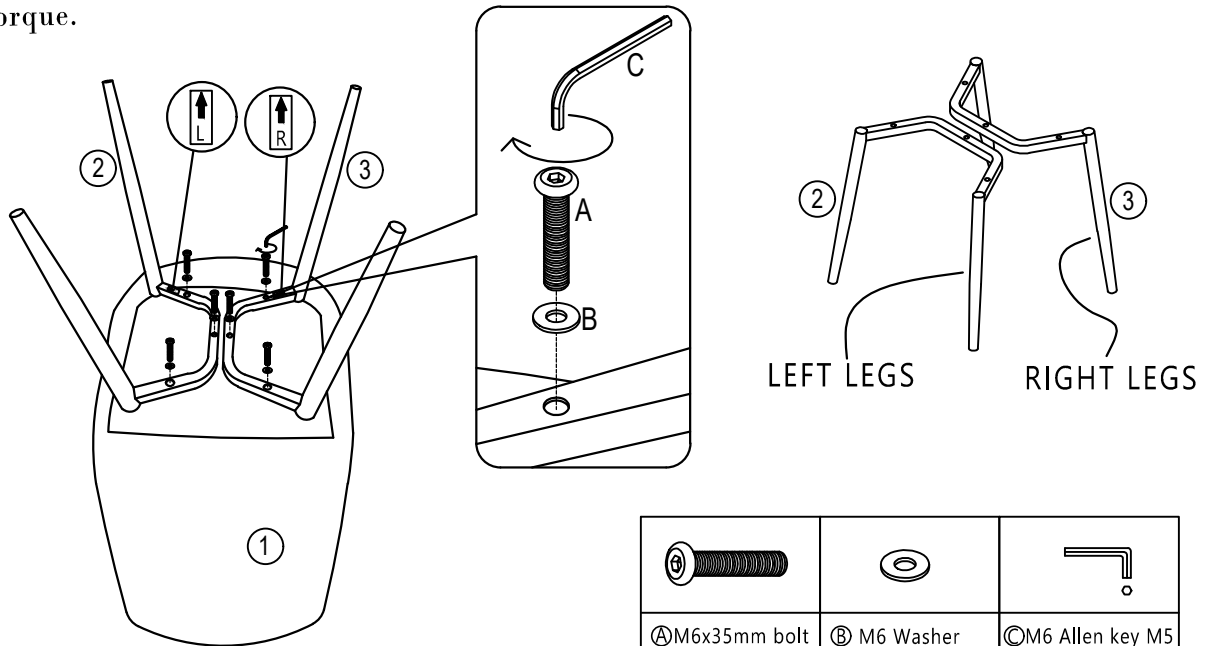

NOTE

Please note the "↑L↑R" labels on the legs.

 Follow the direction of the labels during installation.

Step 2

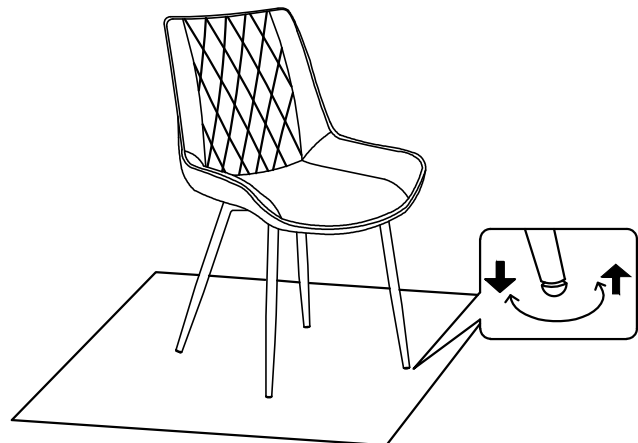
Place chair on a totally flat surface and retighten bolts again with **100%** of required torque until all screws do not turn anymore.



Warning Tips

After you finish all steps, if the chair is unstable yet, pls loss 30% of all screws. Then tighten all screws while pressing on the seat.

CARING FOR YOUR ITEM

- 1 Wipe clean with a dry cloth for the upholstery and frame. Do not use bleach, acid or other abrasive cleaners.
- 2 Do not stand or step on this chair.
- 3 Do not sit on the front edge of the chair. Use for seating only one person at one time.
- 4 Do not use this chair until all bolts, screws and knobs are firmly secured.
- 5 Do not exceed maximum weight capacity of 264 lbs (120 kg).
- 6 This product is intended for domestic indoor use only. Avoid direct contact with sunlight.



QUESTION & ANSWER

1. I received a damaged package

When you receive a damaged box, please open this package and check if there are any damaged or missing components inside the box. If so, please provide pictures and contact us through the platform. We will promptly resolve your issue.

2. I received the wrong color or product, which is not what I ordered

Please provide the following pictures as requested and send them to us through the platform. We will provide a solution as soon as we receive your pictures:

- the item No. on the package.
- the shipping label on the package.
- the actual item you received.

3. My order is incomplete

Normally, we will send you 1, 2 or 3... packages according to your order. If product you received is incomplete, please contact us to update other package information to you. Missing parts should be reported within 48 hours after delivery. Please email us a description. Once the email and photos have been received, we will contact you to send out spare parts.

4. My item is faulty

If your item faulty, please provide us with some pictures or videos (if the box is also damaged) through the platform, and we will provide a solution after receiving your pictures. We do our best to make sure all orders arrive in perfect condition. In the rare event that it does not, our customer services team is here to help.

RETURN & REFUND

While we hope you'll be happy with Furniture items, if sometimes you need to return them. This policy has all the information you'll need to know.

1. How to cancel my order?

If you wish to cancel your order for any reason, please contact us immediately. Only orders that have not yet been dispatched can be canceled. If the order has already been dispatched we will not be able to cancel at the platform and the below policy will apply.

2. How do I make a return?

If you wish to return an item that is no problem. We're happy to offer a refund or an exchange, as long as it's within the return period. You must return the item(s) to us within 30 days of receiving your order. To make the return process as quick and smooth as possible, please follow the below steps:

a. Contact us by email within 30 days of your delivery to let us know you would like to return or exchange as well as why you would like to do so. We will solve the problem for you then.

b. Make sure the item your order is in the original boxes. If you have not kept the original boxes, it is your responsibility to make sure the products are re-boxed, we do not provide additional boxes. Items must not have been used or assembled in any way. Please include the return slip in the box or write your order number on the outside.

3. Receiving your refund

When we reach a consensus, we will refund the money to the same way you paid for the product.

Please allow up to 5-14 working days for the refund to show in your account, which is the time for the bank to operate the refund.