

EN:

ATTENTION PLEASE!

The chair may wobble if not assembled right, For correction, loosen the screws by 2-3 revolutions, sit on the chair to make sure all four legs are on the same surface, then re-tighten the screws.

To deodorize the leather leave the chair in a shady outside for 1-2 days.

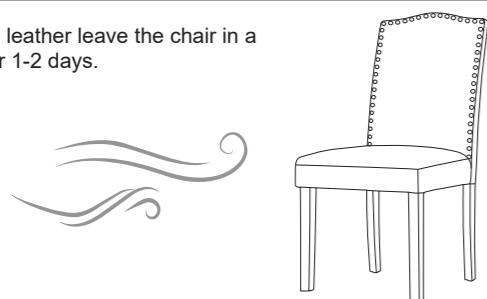

Tighten bolts periodically.

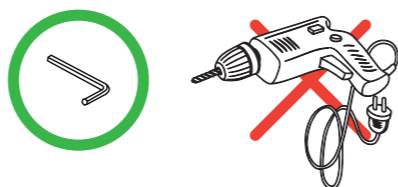

ES:

¡ATENCIÓN!

La silla puede tambalearse si no está bien ensamblada. Para corregirlo, afloje los tornillos entre 2 y 3 vueltas, siéntese en la silla para nivelar las cuatro patas sobre la misma superficie, y vuelva a apretar los tornillos.

Para desodorizar el cuero, deje la silla en un lugar sombreado al aire libre durante 1-2 días.



Apriete los tornillos periódicamente.

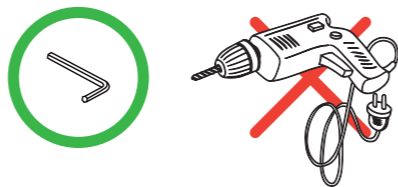

FR:

ATTENTION, S'IL VOUS PLAÎT !

La chaise peut vaciller si elle n'est pas correctement assemblée. Pour corriger cela, desserrez les vis de 2 à 3 tours, asseyez-vous sur la chaise pour vous assurer que les quatre pieds touchent le sol, puis resserrez les vis.

Pour désodoriser le cuir, laissez la chaise dans un endroit ombragé à l'extérieur pendant 1 à 2 jours.

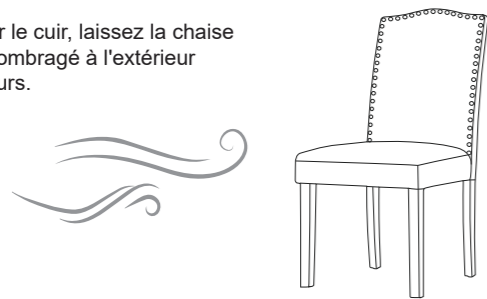

Serrez les boulons périodiquement.

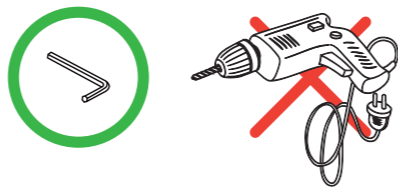

INSTRUCTION MANUAL MANUAL DE INSTRUCCIONES MANUEL D'INSTRUCTIONS

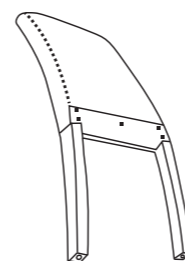
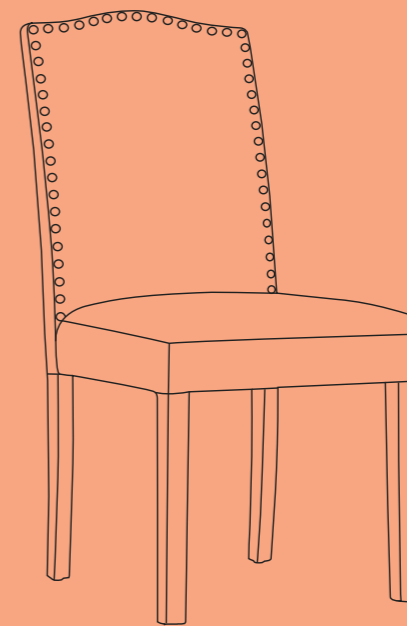

(A)*1

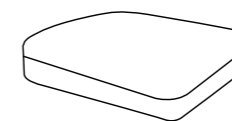

(B)*1



(C)*2

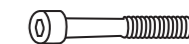

(E)*4
M8*75mm



(F)*5
M8*55mm



(H)*9



(I)*9



(J)*1

Safety Information / Información de seguridad / Informations Relatives à la Sécurité



Step 1

EN: Non-woven
ES: Tela no tejida
FR: Non-tissé

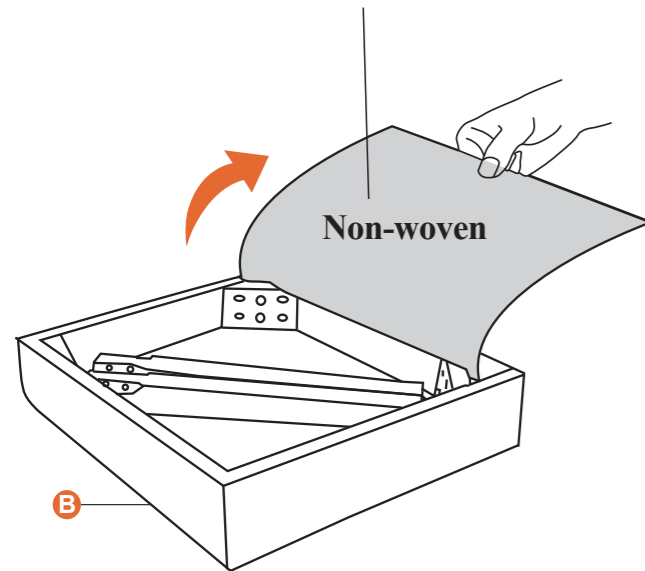

Step 2

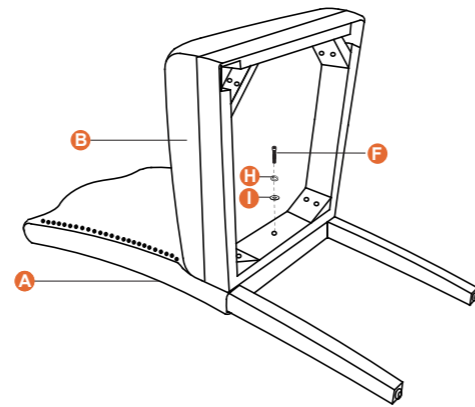
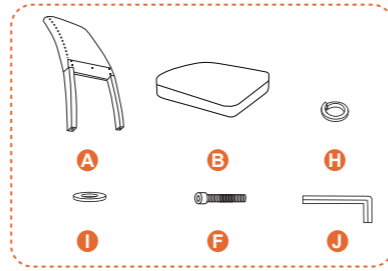

EN: Do not tighten the bolts.
ES: NO apriete todavía los tornillos.
FR: NE SERREZ PAS les boulons pour l'instant.

Step 5

EN: Place the assembled unit on a flat surface.
Press the seat to make sure the legs are level.

ES: Coloque la unidad ensamblada sobre una superficie plana. Presione el asiento para asegurarse de que las patas estén niveladas.

FR: Placez l'unité assemblée sur une surface plane. Appuyez sur le siège pour vous assurer que les pieds sont bien de niveau.

Step 6

EN: Tighten all the bolts!

ES: Apriete bien todos los tornillos.

FR: Serrez tous les boulons !

Step 3

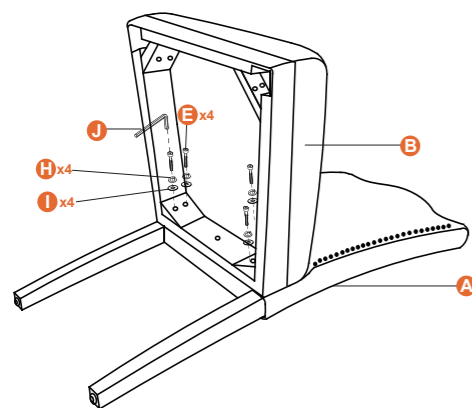

EN: Do not tighten the bolts.
ES: NO apriete todavía los tornillos.
FR: NE SERREZ PAS les boulons pour l'instant.

Step 4

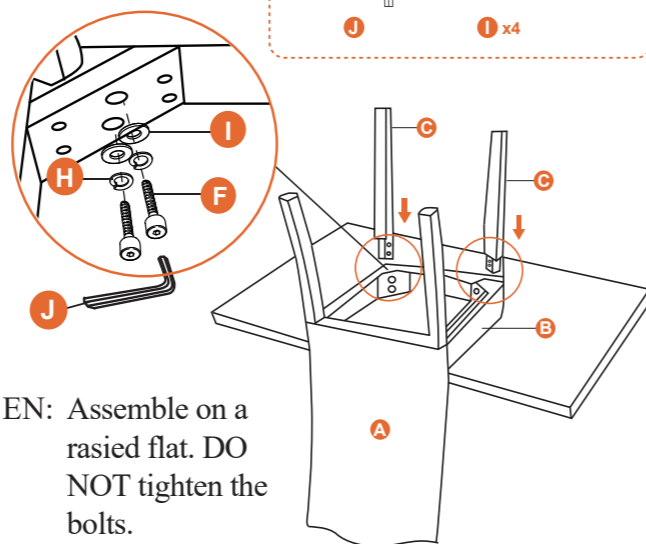
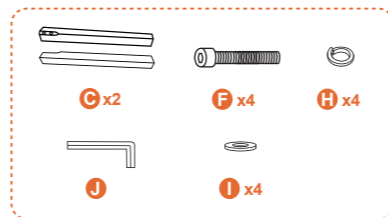

EN: Assemble on a raised flat. DO NOT tighten the bolts.
ES: Ensámblelo sobre una superficie plana y elevada. NO apriete todavía los tornillos.
FR: Assemblez sur une surface plane surélevée. NE SERREZ PAS les boulons pour l'instant.

Step 7

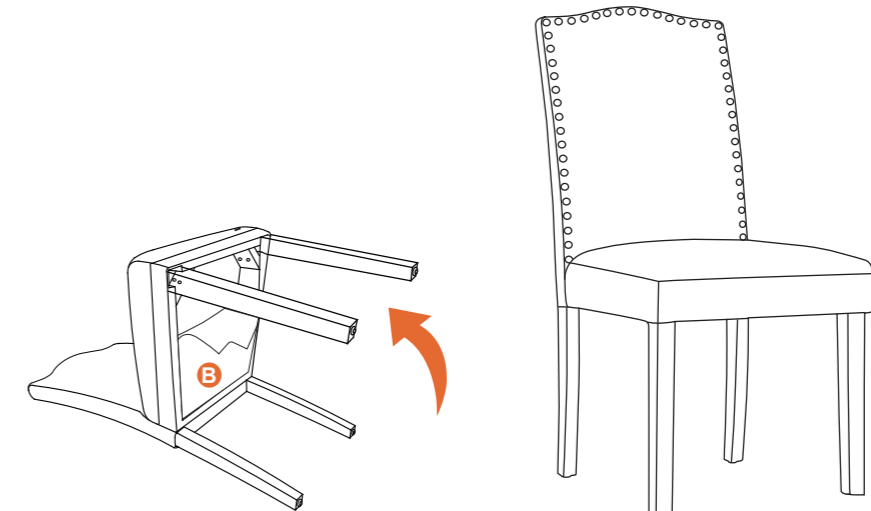

EN: Seal the Seat Bottom Cover at the bottom of the Seat Cushion (B).
ES: Cierre la cubierta inferior del asiento (B).
FR: Fixez le couvercle inférieur de l'assise sous le coussin de siège (B).