

Product size:
W80*D80*H35cm

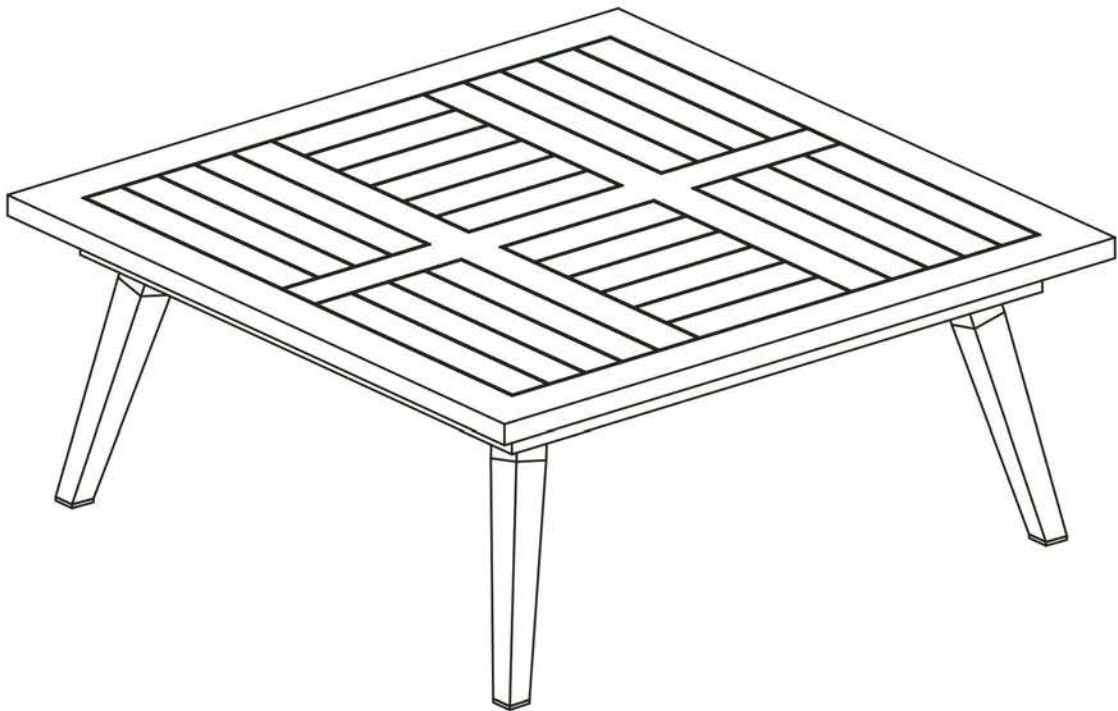

The intended use of this product is for domestic use only.

Important, please retain for future reference.

Read carefully.

80 x 80cm Aluminium Table

Assembly Instructions

Before you start



Warnings

IMPORTANT, RETAIN FOR FUTURE REFERENCE READ CAREFULLY

See enclosed instructions for assembly, safety and care information.

Failure to follow the warnings could result in serious injury.

Handle heavy parts with care.

Ensure that this product is fully assembled as illustrated before use.

This product should only be used on firm, level ground.

Keep small parts out of reach of children.

Do not stand or climb onto this product.

This product is intended for **domestic use** only.

Furniture can be dangerous if incorrectly used. No liability will be accepted for damage or injury caused by incorrect use of this product.



Dos

When you are ready to start, make sure that you have the right tools, plenty of space and a clean, dry area for assembly.

Removing all packaging and banding and place the components carefully on suitable surfaces to prevent damaging or scratching them.

Check the pack and make sure you have all of the parts listed.

Check all screws and bolts are tightened and inspect regularly.

This product is suitable for all year outdoor use.

However to prolong its life we recommend that during severely bad weather and during the winter months, it is stored in a cool, dry place.

Before storage, ensure that the product is clean and dry.

To clean, wipe down with a sponge and warm soapy water and wipe with a clean, dry cloth.
sponge and warm soapy water and wipe with a clean, dry cloth.

X Don'ts

Do not use scourers, abrasives, washing powders, chemical cleaners or any other substances containing abrasives since these substances can damage the product, including the glass panel.

Do not place very hot or very cold items on the glass surface unless adequately thick table-mats are used to prevent such items from coming into contact with the glass.

Do not use the glass as a chopping surface.

Do not strike the glass with hard or pointed items.

Do not use power tools to construct this product.

Do not use this product if parts are missing, damaged or worn.

Do not sit or lean on this product.

Do not stand or climb onto the product and do not use it as a ladder, as this could lead to it unbalancing and overturning.

Never drag furniture when moving it, always lift it.

Number of people required for assembly

Two people.

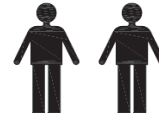

Time to assemble



10 Minutes

Tools required







Tips:

Do NOT fully tighten bolts before all components are connected. Only fully tighten once you are satisfied with the alignment of all components.

Do not over-tighten the bolts.

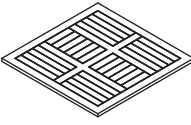
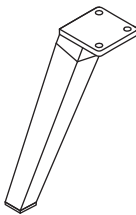
80 x 80cm Aluminium Table Assembly Instructions

Components, fixtures & fittings (not actual size)

Parts List					
Part No.	Diagram	Qty.	Part No.	Diagram	Qty.
A	 Table Top	1 PC	B	 Table Leg	4 PCS
F2	 Bolt Head Cap	12 PCS	W25	 M6*25mm Bolt	12 PCS
F3	 Flat Washer	12 PCS	S1	 Spanner	1 PC

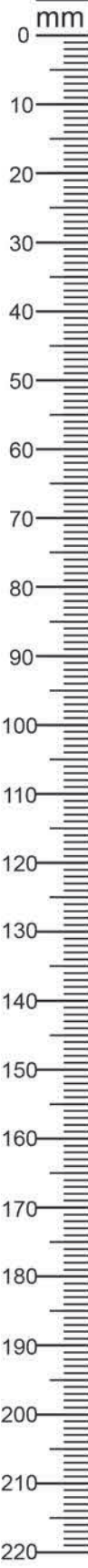

80 x 80cm Aluminium Table Assembly Instructions

Step by step assembly instructions

All Bolt Head Caps should not be attached before finally tightening all Bolts with Spanner.

Step One

With the help of another person, open the packaging, place Table Top (A) upside down on a flat, non-abrasive surface to avoid scratching the table surface or rim.

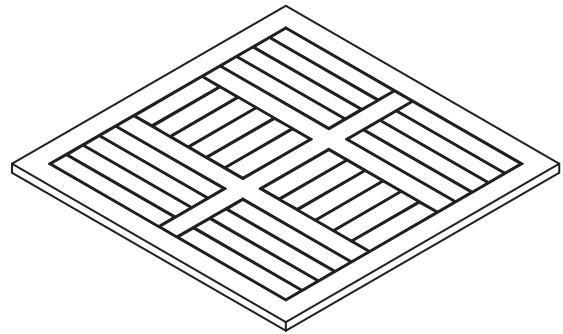

Step Two

Loosely attach the Table Legs (B) to the Table Top (B) using Bolt Head Caps (F2), Bolts (W25), and Flat Washers (F3).

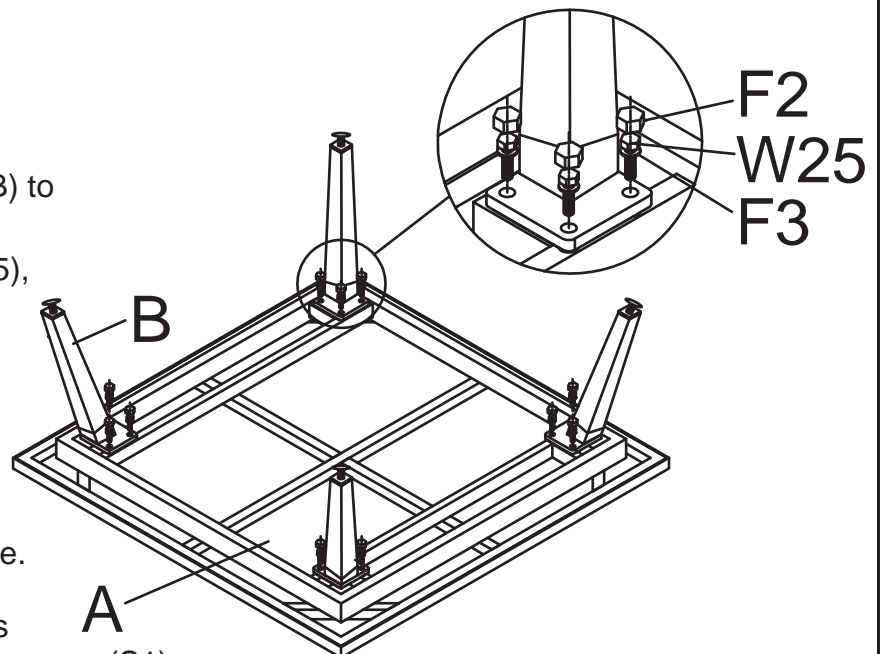

Only tighten the bolts when all bolts and washers are in place. Once you are satisfied with the alignment of the components carefully tighten all bolts using Spanner (S1). Do not over-tighten. Cover each bolt with Bolt Head Cap (F2).

80 x 80cm Aluminium Table Assembly Instructions

Step Three

With the help of another person, carefully turn the table in the upright position. Level the table by adjustable feet screw.

Your table is now ready for use.

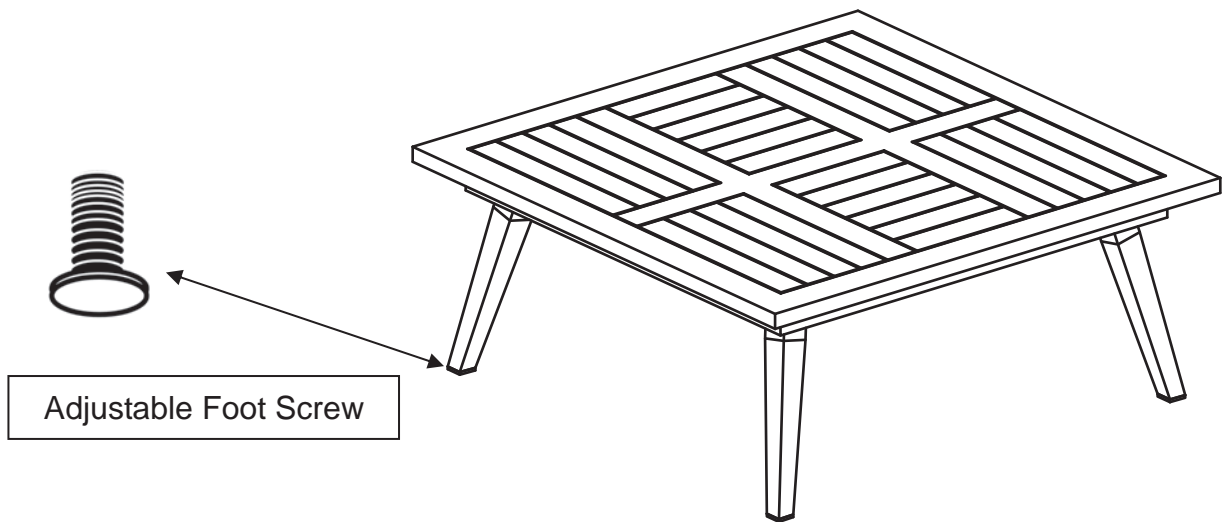

PLEASE KEEP THESE INSTRUCTIONS FOR FUTURE REFERENCE