

Outdoor Sink

SKU: LTFA5266

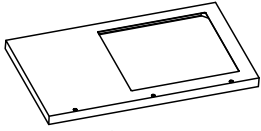

parts and components I



① 1X

Aluminum Worktop



② 2X

Aluminum Legs

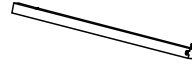

③ 2X

Aluminum Legs

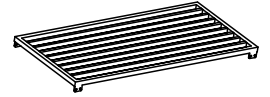

④ 1X

Aluminum Shelf

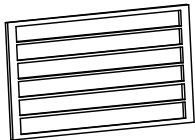

⑤ 1X

Aluminum Shelf

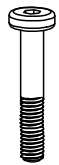

M6X55

⑥ 3X

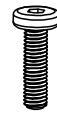

M6X18

⑦ 18X



D6

⑧ 21X

Stainless Steel Washers



⑨ 1X

Hex-L Key



⑩ 1X

Metal Bracket



⑪ 1X

Protective Cover

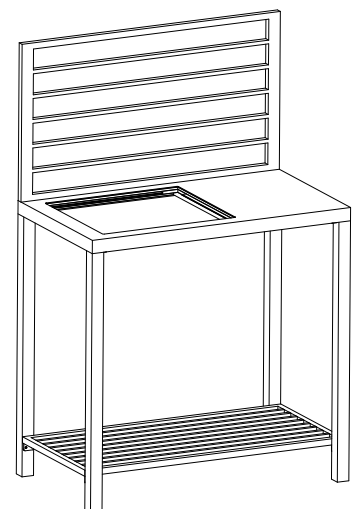

Step 1



① 1X

Aluminum
Worktop

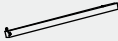

② 2X

Aluminum
Legs

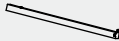

③ 2X

Aluminum
Legs



M6X18

⑦ 8X



⑧ 8X

Stainless Steel
Washers



⑨ 1X

Hex-L Key

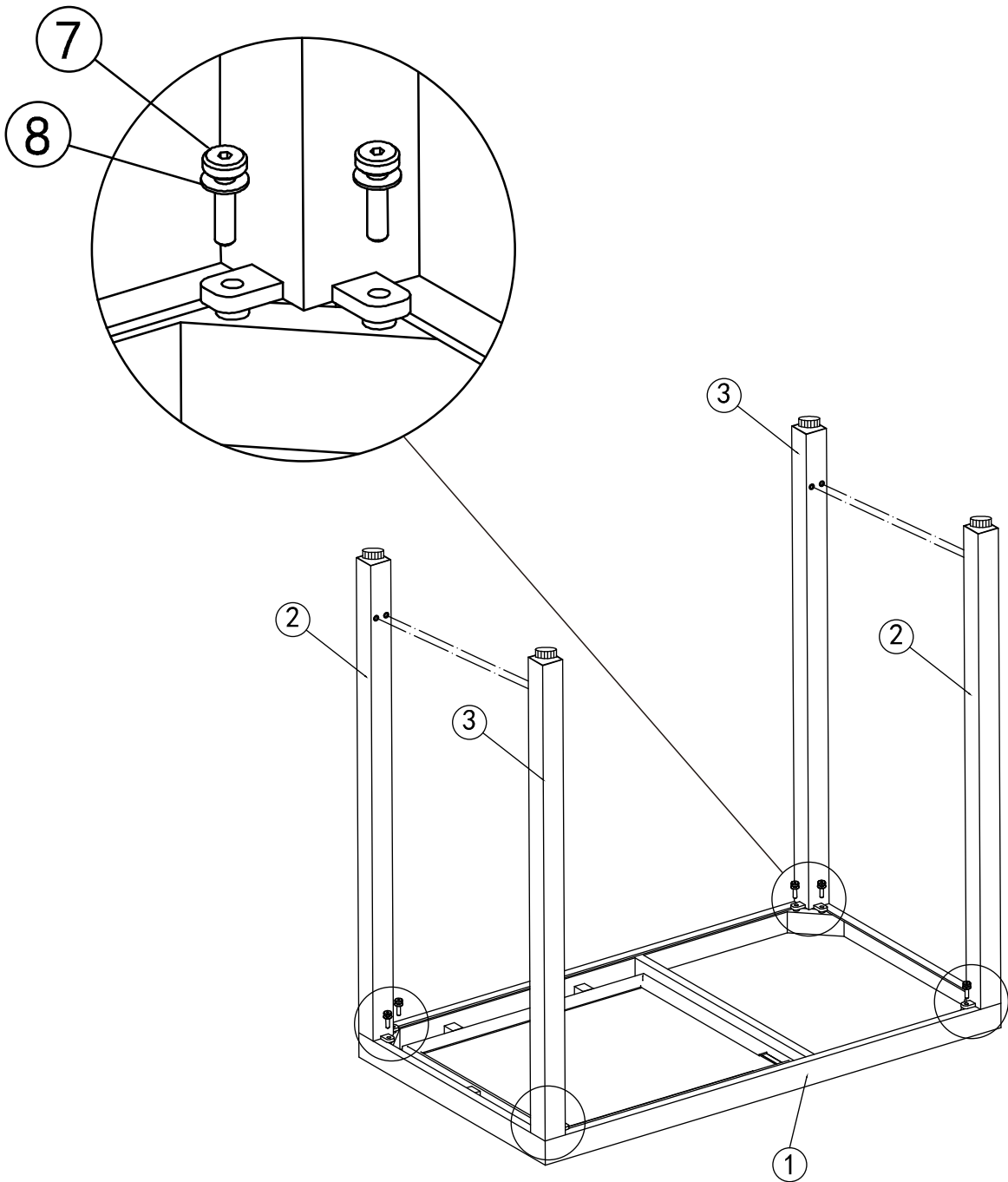

Step 2

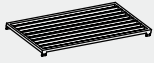

④ 1X

Aluminum Shelf



⑦ 8X



⑧ 8X

Stainless Steel Washers



⑨ 1X

Hex-L Key

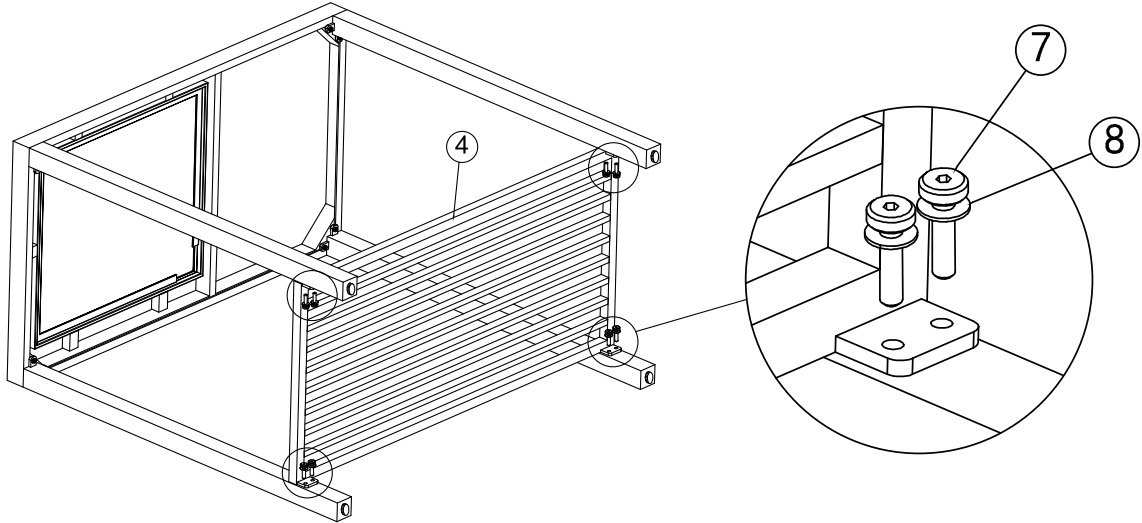

Step 3



⑤ 1X

Aluminum Shelf



⑥ 3X



⑧ 3X

Stainless Steel Washers

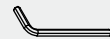

⑨ 1X

Hex-L Key

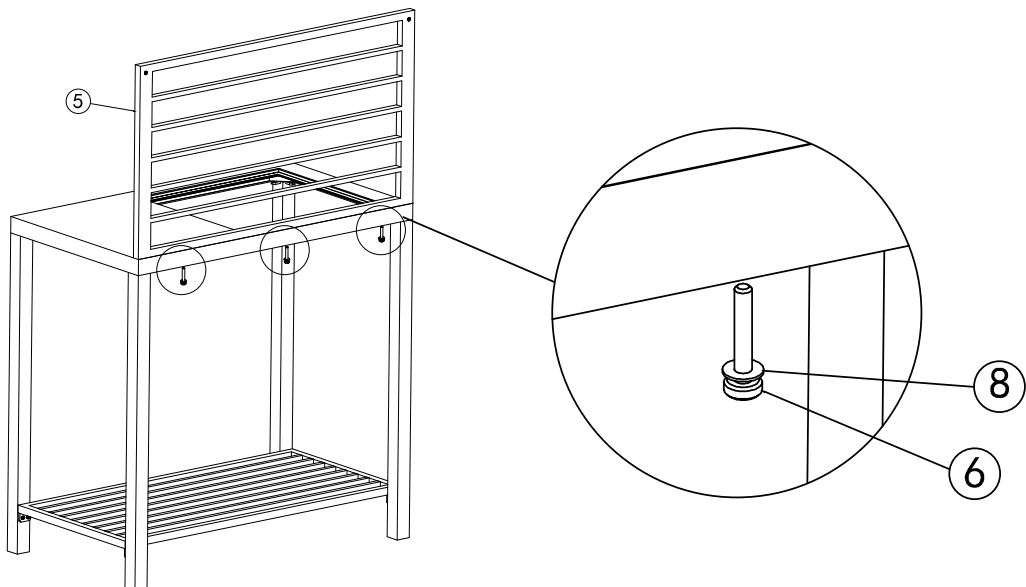

Step 4

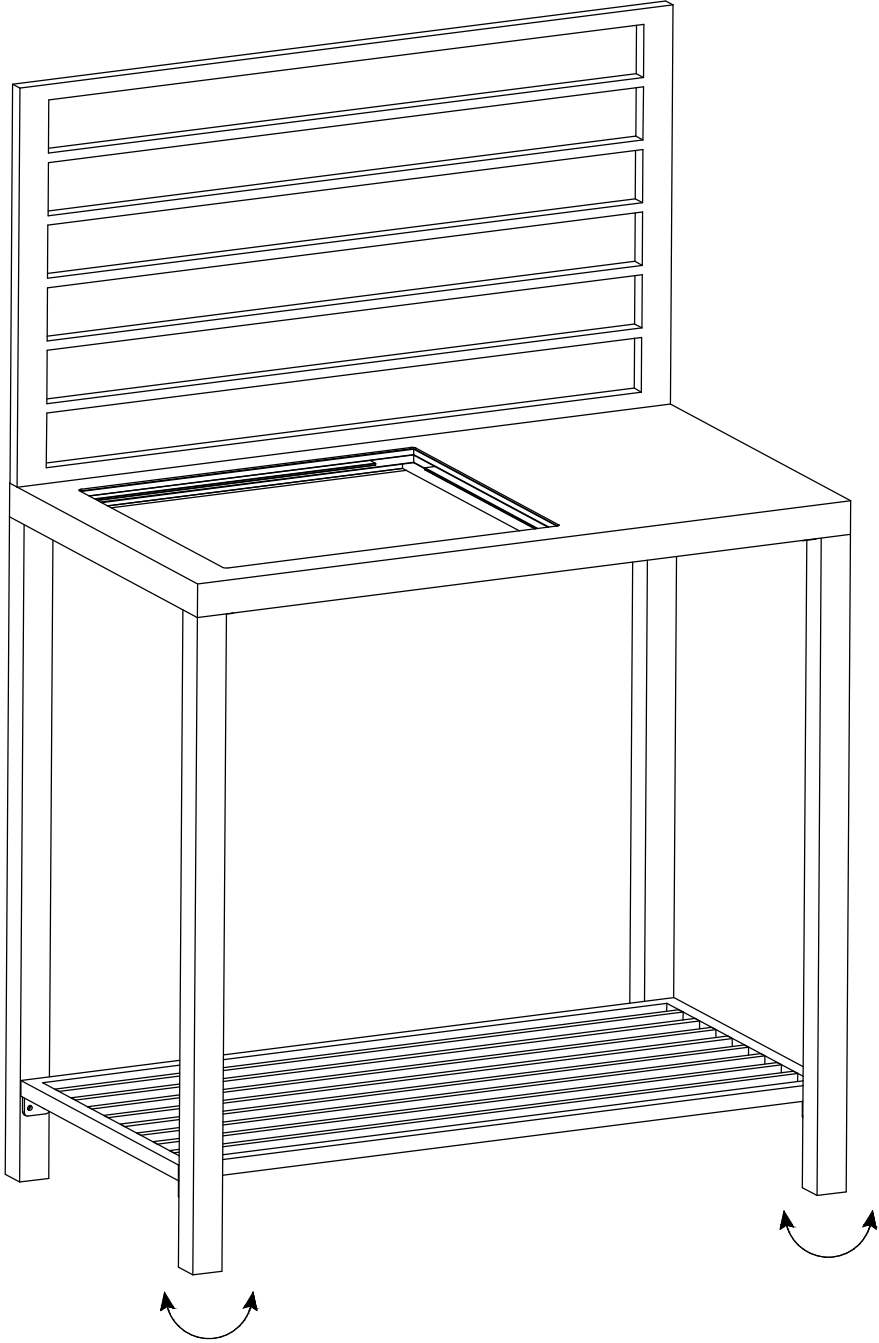

parts and components II



① 1X

Sink

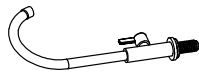

② 1X

Sink Faucet



③ 1X

Faucet Rubber Washer



④ 1X

Faucet Plastic Lock Nut



⑤ 1X

Inlet Hose



⑥ 1X

Sink Strainer Body



⑦ 1X

Sink Plastic Lock Nut



⑧ 1X

Sink Strainer



⑨ 1X

Drain Stopper



⑩ 1X

Drain Pipe Rubber Washer



⑪ 1X

Main Drain Pipe

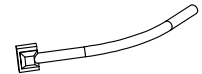

⑫ 1X

Side Drain Pipe



⑬ 1X

Sink Foam Washer



⑭ 1X

Sink Rubber Washer



⑮ 1X

Screwdriver



⑯ 1X

PTFE Sealant Tape

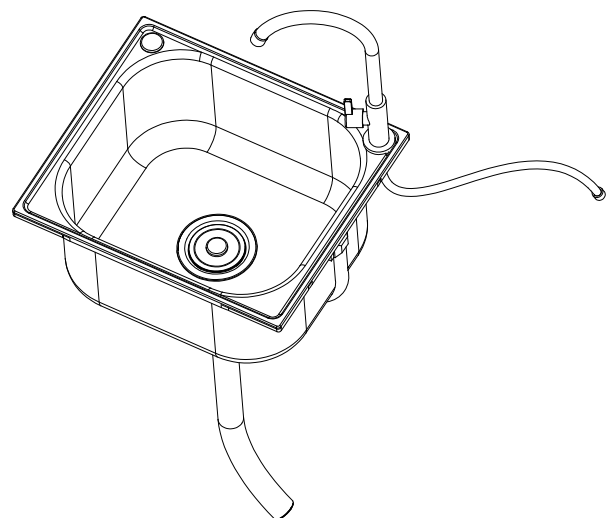

Step 1



① 1X

Sink

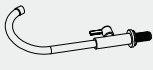

② 1X

Sink Faucet



③ 1X

Faucet Rubber Washer



④ 1X

Faucet Plastic Lock Nut

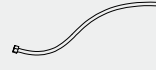

⑤ 1X

Inlet Hose



⑬ 1X

PTFE Sealant Tape

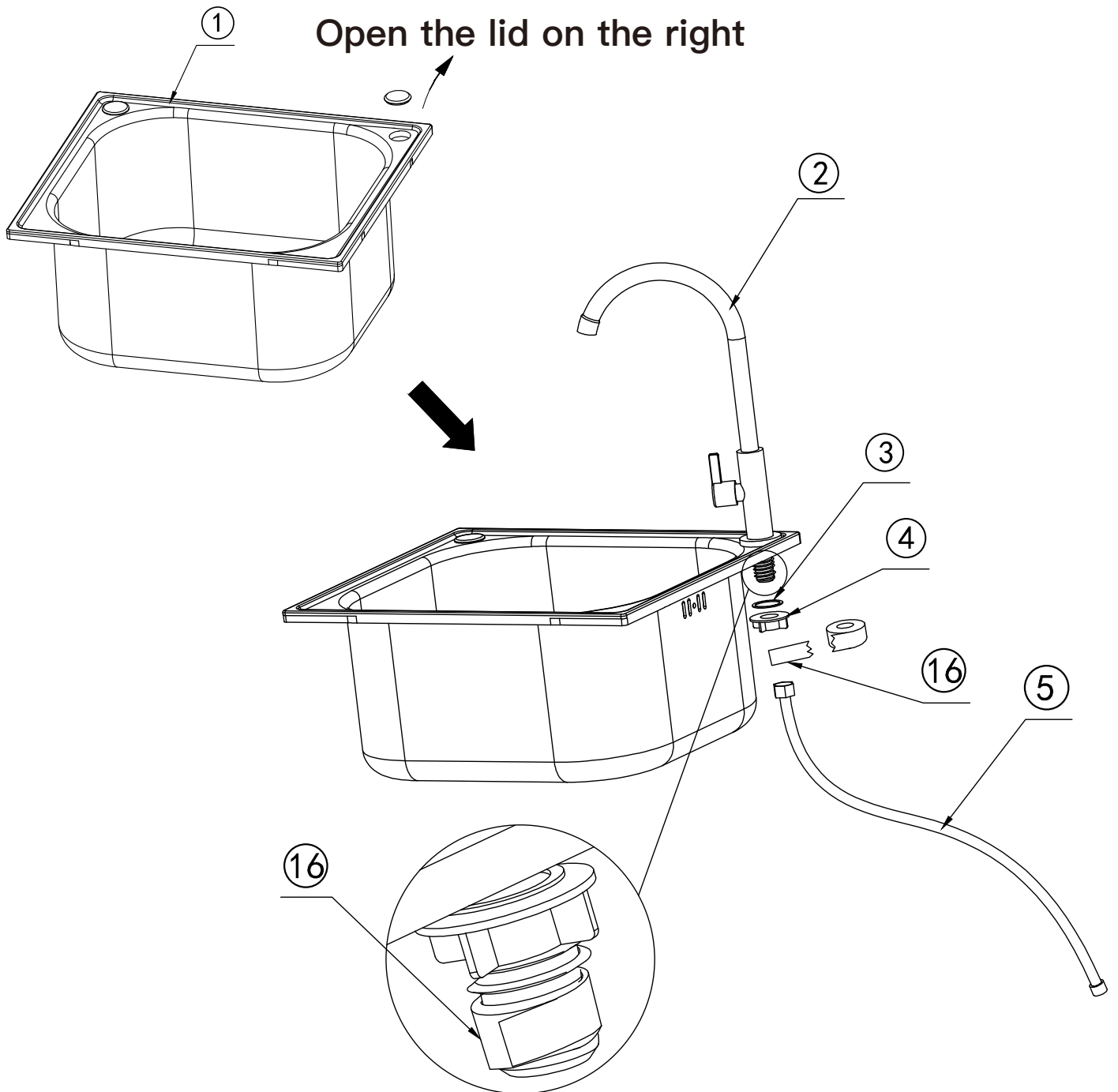

Wrap waterproof tape around it

Step 2



⑥ 1X

Sink Strainer
Body



⑦ 1X

Sink Plastic
Lock Nut



⑩ 1X

Drain Pipe
Rubber Washer

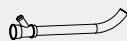

⑪ 1X

Main Drain
Pipe



⑬ 1X

Sink Foam
Washer



⑭ 1X

Sink Rubber
Washer

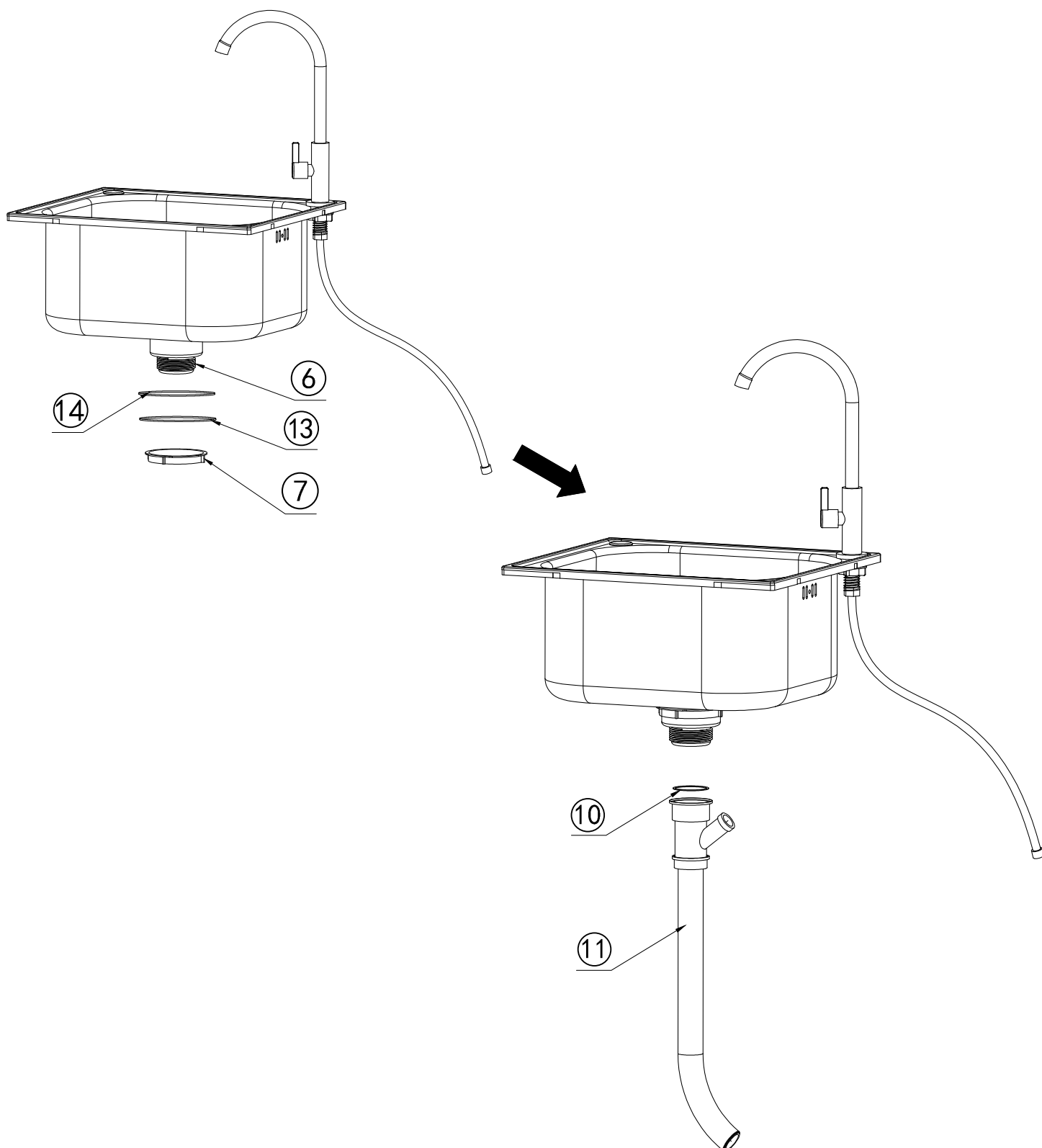

Step 3



⑫ 1X
Side Drain
Pipe



⑮ 1X



⑰ 1X

Screwdriver

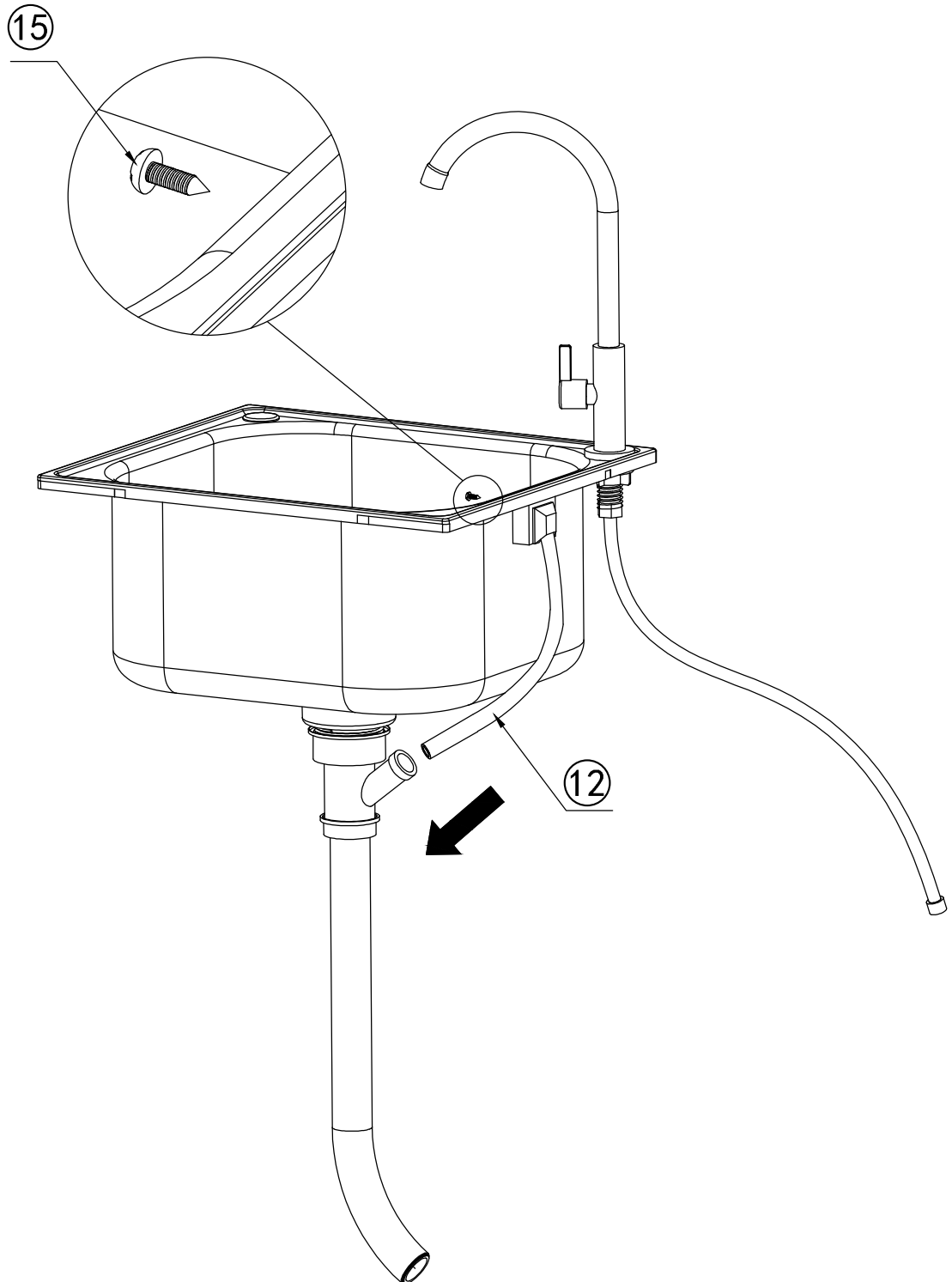

Step 4



8 1X

Sink Strainer



9 1X

Drain Stopper

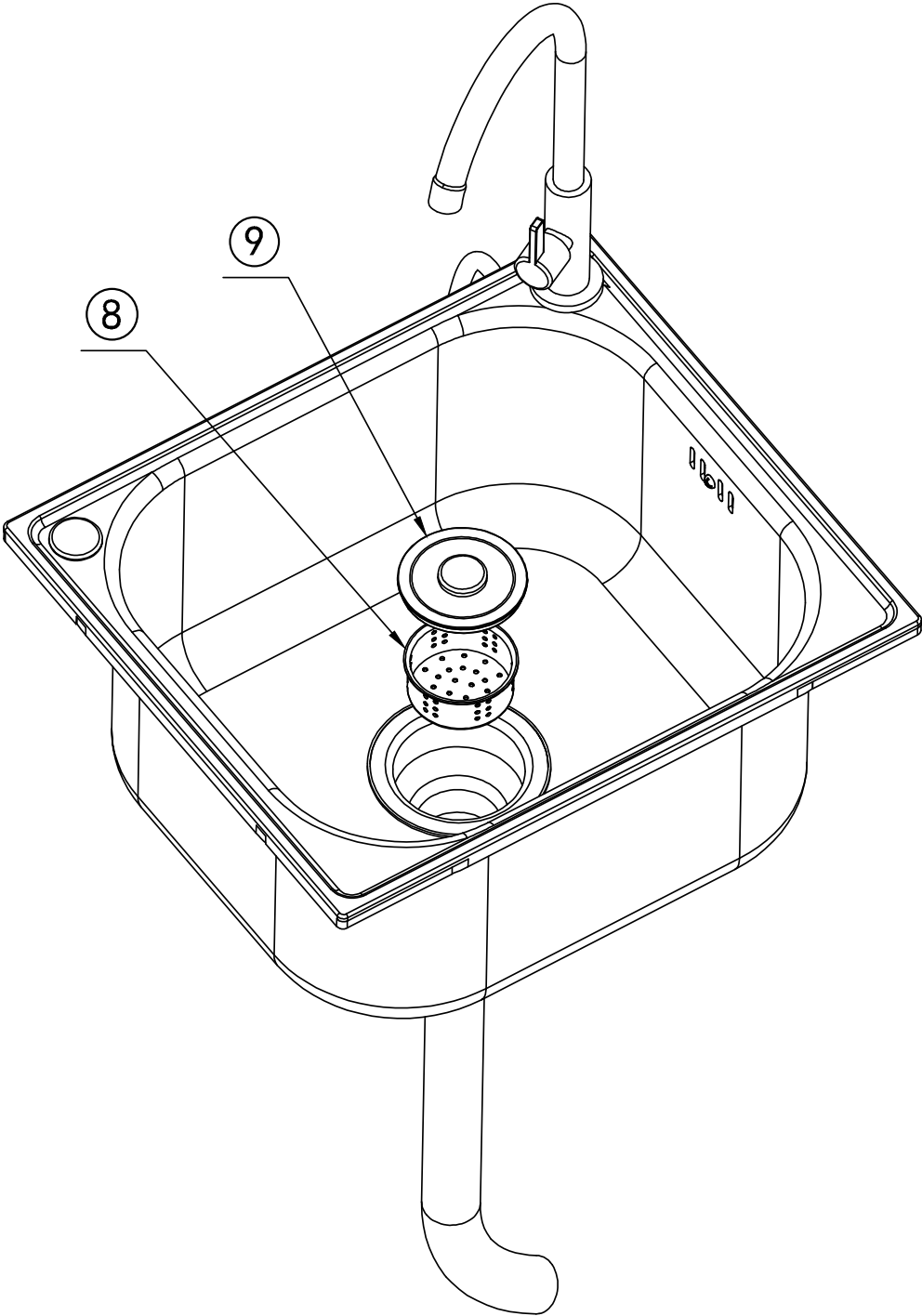

Step 5

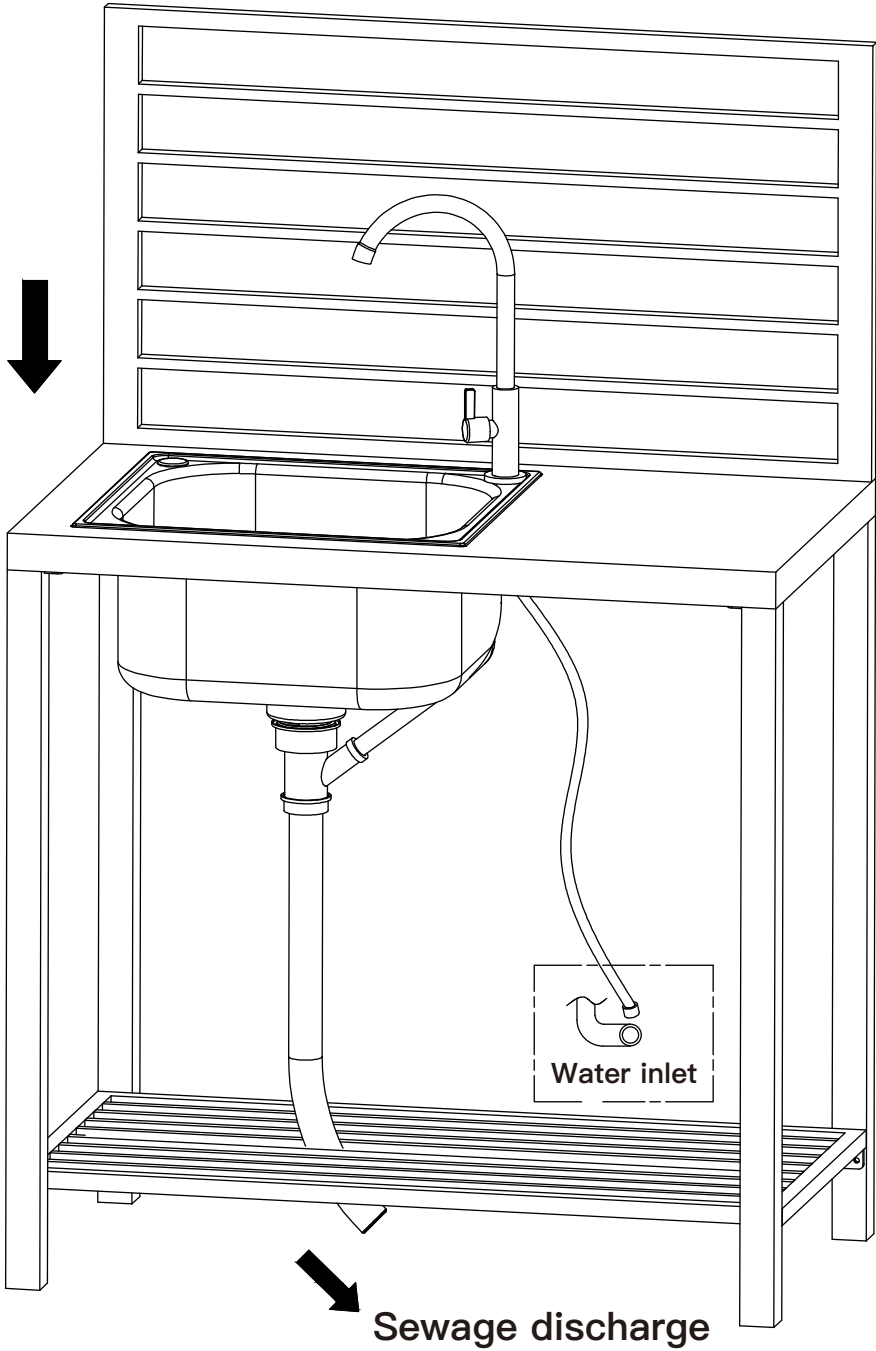

about the outdoor kitchen series

We created the Outdoor Kitchen line because we want everyone to enjoy the outdoors! All outdoor kitchen lines are modular in design, fit together seamlessly and are made of sturdy, durable aluminum countertops for easy connection. Like all domi outdoor products, the Outdoor Kitchen series has stood the test of time and will become a product that consumers trust.



Missing part? Damaged? Contact us via email at service@domioutdoorliving.com

www.domioutdoorliving.com

Series products

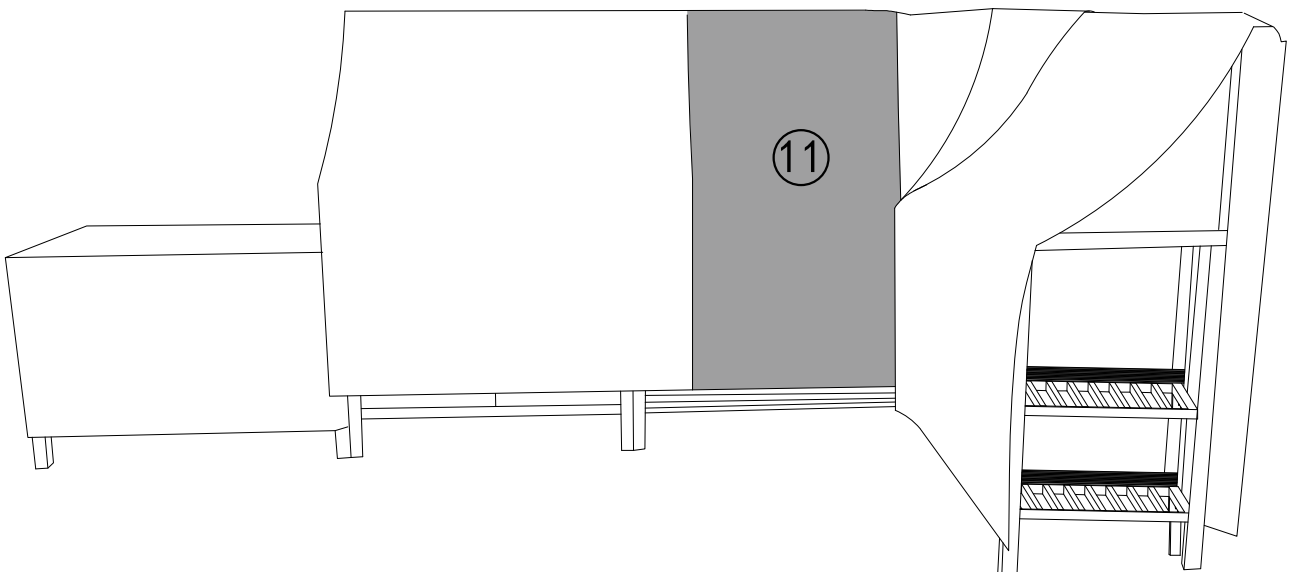
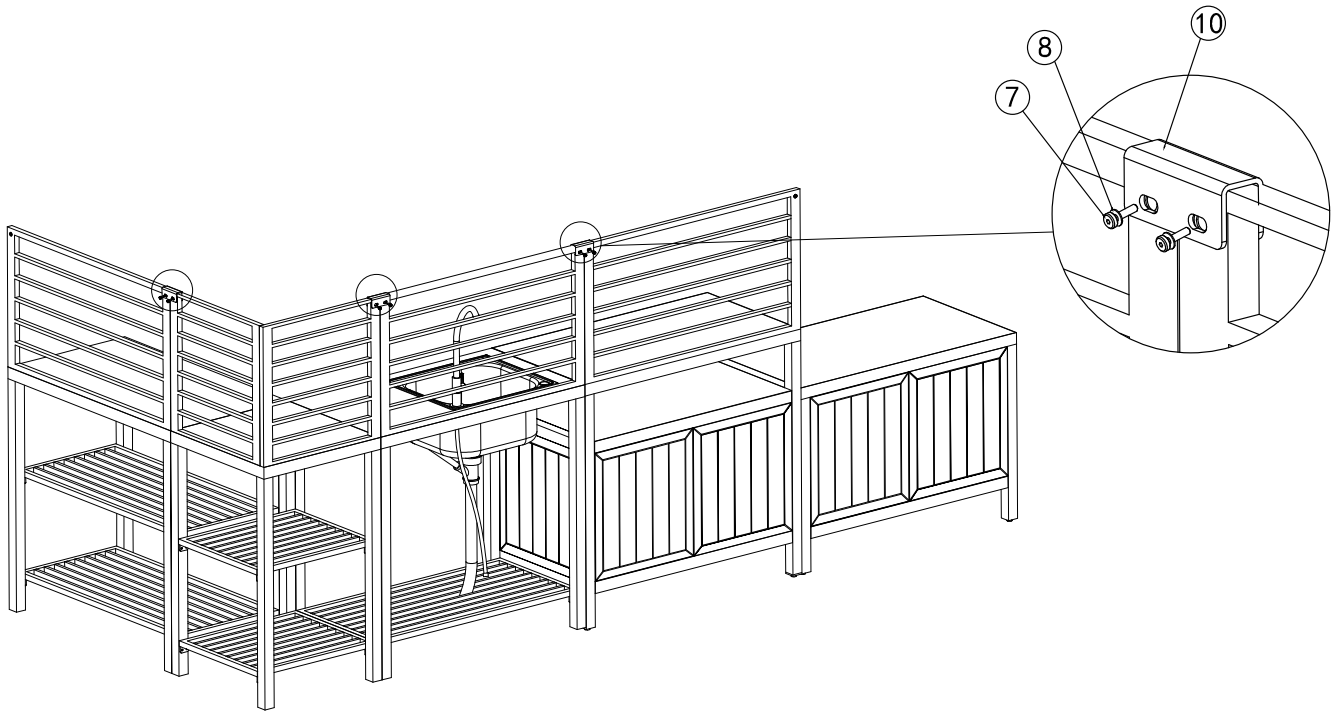
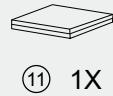
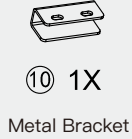

about the outdoor kitchen series

We created the Outdoor Kitchen line because we want everyone to enjoy the outdoors! All outdoor kitchen lines are modular in design, fit together seamlessly and are made of sturdy, durable aluminum countertops for easy connection. Like all domi outdoor products, the Outdoor Kitchen series has stood the test of time and will become a product that consumers trust.



Missing part? Damaged? Contact us via email at service@domioutdoorliving.com

www.domioutdoorliving.com
