



**EN\_** Assembly video please scan the QR code.

**FR\_** Vidéo d'assemblage, veuillez scanner le code QR.

**ES\_** Montaje video scannen Sie bitte den QR-Code ein.

**PT\_** Vídeo de montagem por favor digitalizar o código QR.

**DE\_** Vídeo de montaje, escanea el código QR.

**IT\_** Scansionare il codice QR per il Video di Assemblaggio

**EN\_** IMPORTANT, RETAIN FOR FUTURE REFERENCE: READ CAREFULLY.

**FR\_** IMPORTANT: A LIRE ATTENTIVEMENT ET À CONSERVER POUR CONSULTATION  
ULTÉRIEURE.

**ES\_** IMPORTANTE, LEA Y GUARDE PARA FUTURAS REFERENCIAS.

**PT\_** IMPORTANTE, RETER PARA REFERÊNCIA FUTURA: LEIA ATENTAMENTE.

**DE\_** WICHTIG! SORFGFÄLTIG LESEN UND FÜR SPÄTERES NACHSCHLAGEN AUFBEWAHREN.

**IT\_** IMPORTANTE! CONSERVARE IL PRESENTE MANUALE PER FUTURO RIFERIMENTO E  
LEggerlo attentamente.

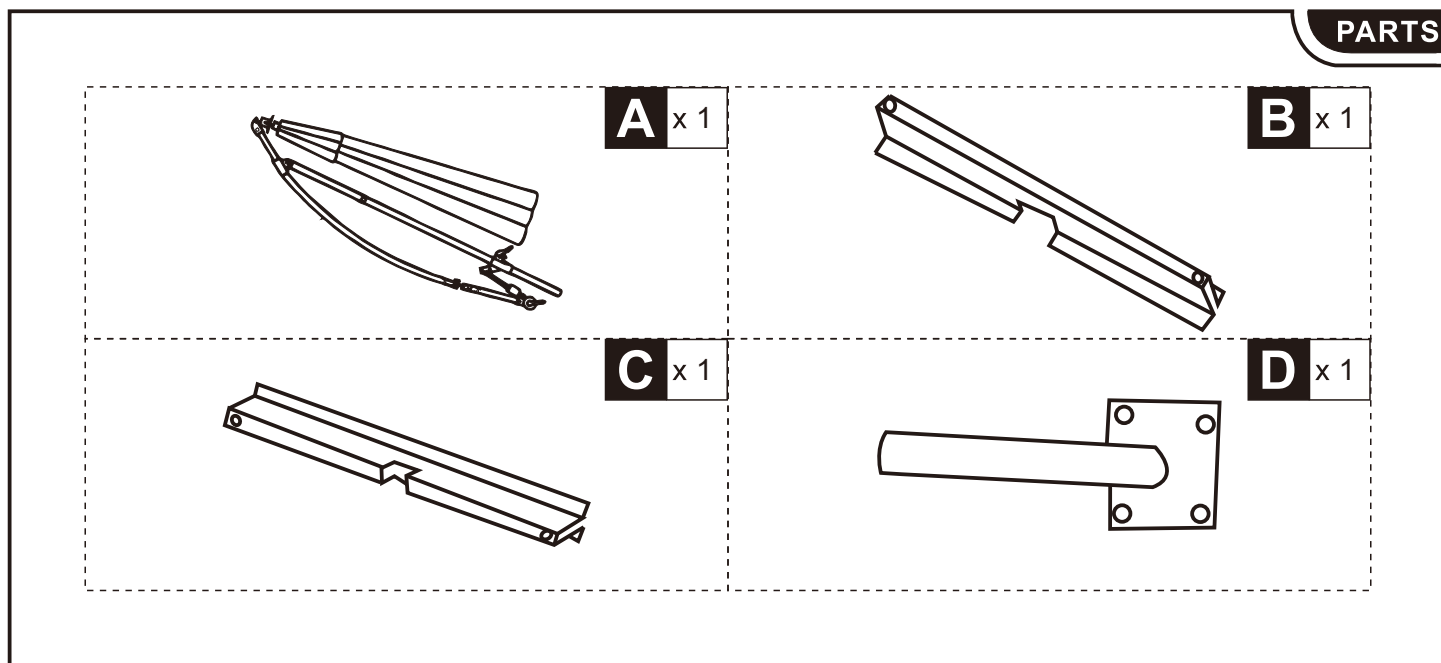

## NOTE

**EN\_Tips:** Please do not use in strong winds to avoid damage. When not in use, please remove the umbrella and store it to keep dry.

**FR\_Conseils :** Évitez les dommages, veuillez ne pas utiliser par vent fort. Lorsqu'il n'est pas utilisé, veuillez retirer le parasol à temps et conservez-le au sec.

**ES\_Consejos:** evitar daños; por favor, no use cuando hace viento. Cuando no esté en uso: por favor retire el paraguas a tiempo, y guárdelo para mantenerlo seco.

**PT\_Dicas:** Por favor não utilizar em ventos fortes para evitar danos. Quando não estiver a ser utilizado, por favor retire o guarda-chuva e guarde-o para se manter seco.

**DE\_Tipps:** Um Schäden vorzubeugen, nutzen Sie das Produkt bitte nicht bei starkem Wind. Wenn nicht in Benutzung, klappen Sie den Schirm bitte zeitnah ein und lagern Sie ihn an einem trockenen Ort.

**IT\_Suggerimenti:** evitare danni, si prega di non utilizzare quando fuori C'è vento. Quando non in uso, si prega di rimuovere l'ombrello tempestivamente e conservare per tenerlo asciutto.

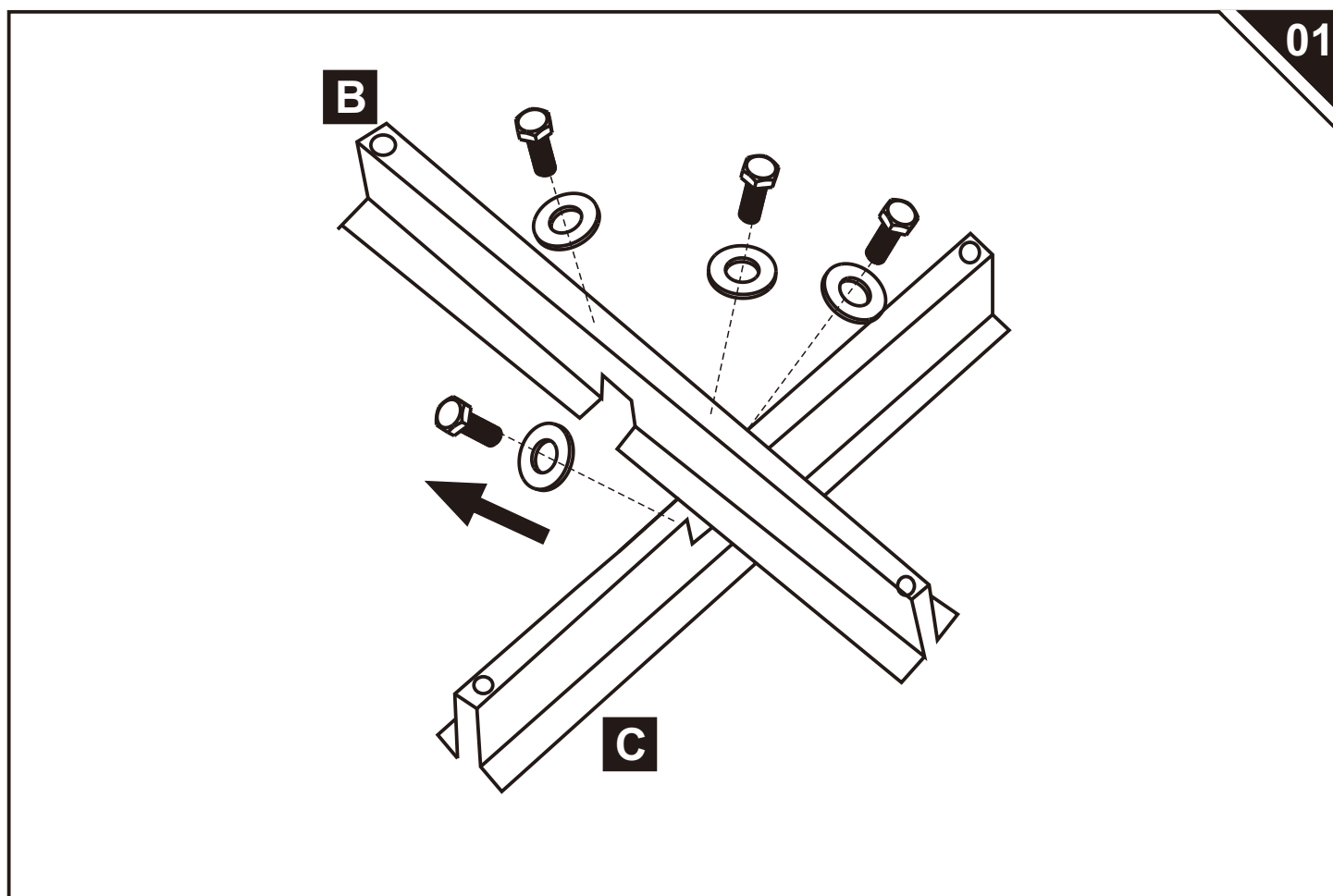

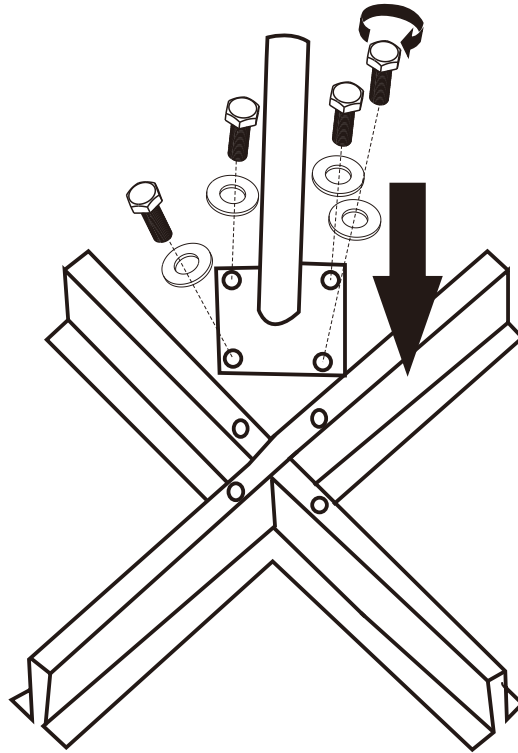

**EN** Slide clamp lever and rotate until hole is visible.  
**FR** Faire glisser le levier de serrage et tourner jusqu'à ce que le trou soit visible.  
**ES** Deslice la palanca de la abrazadera y gírela hasta que el orificio sea visible.  
**PT** Deslize a alavanca do grampo e rode até o orifício ficar visível.  
**DE** Schieben Sie den Klemmhebel und drehen Sie ihn, bis die Bohrung sichtbar ist.  
**IT** Far scorrere la leva del morsetto e ruotarla fino a quando il foro è visibile.

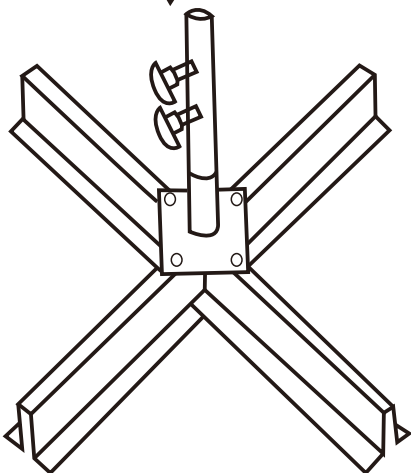
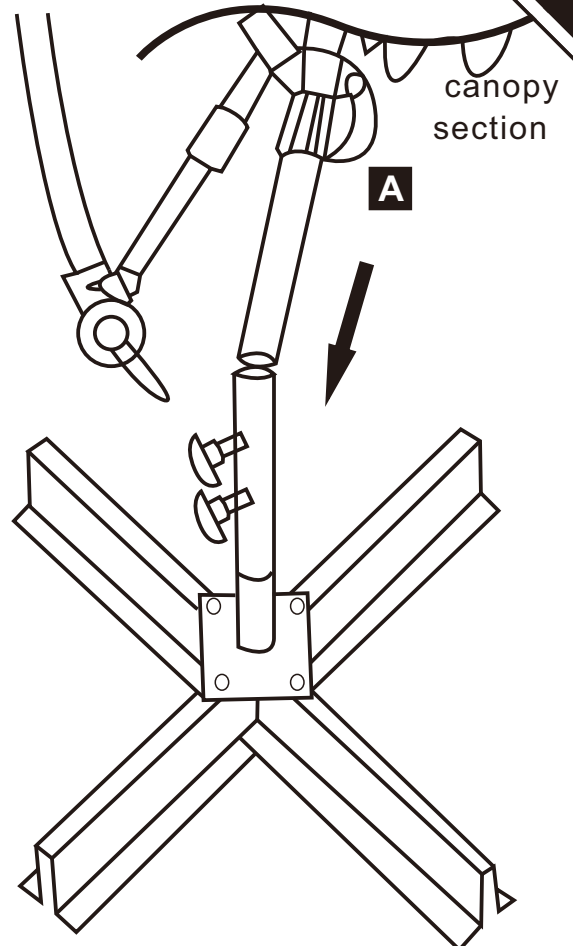

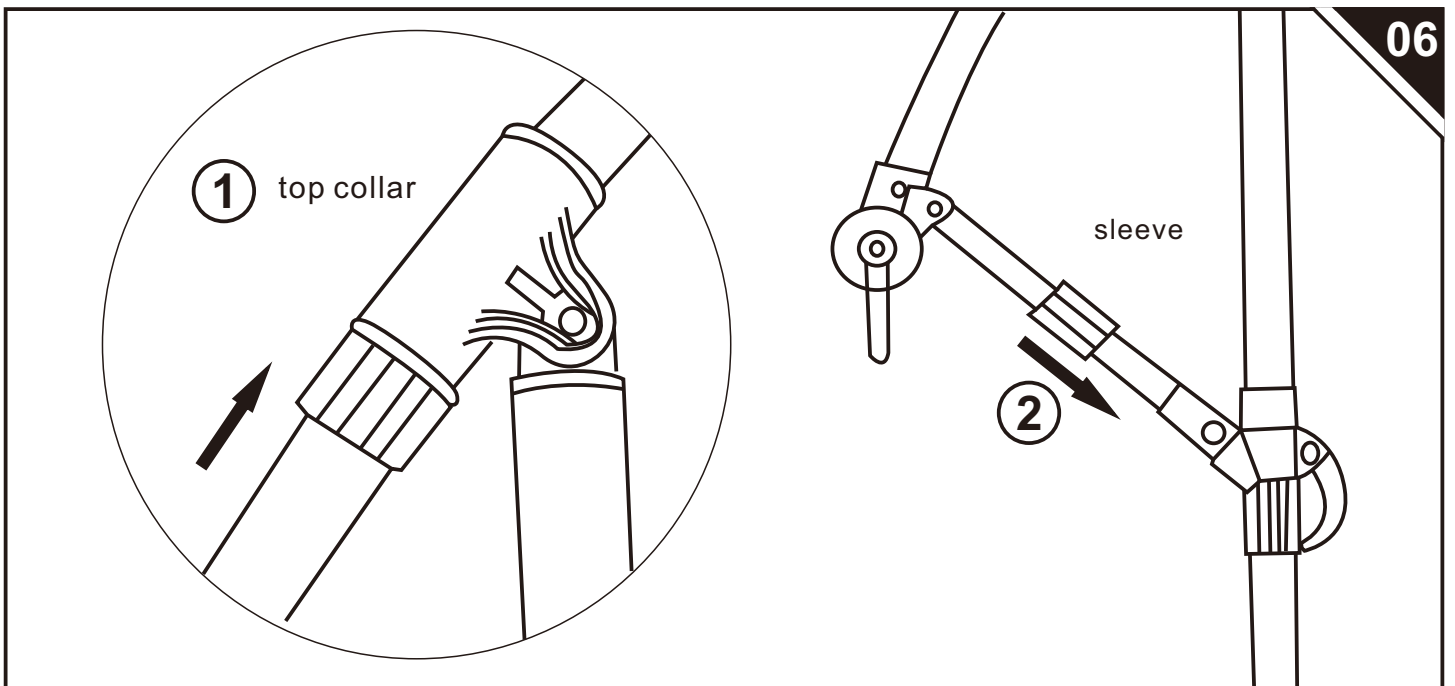
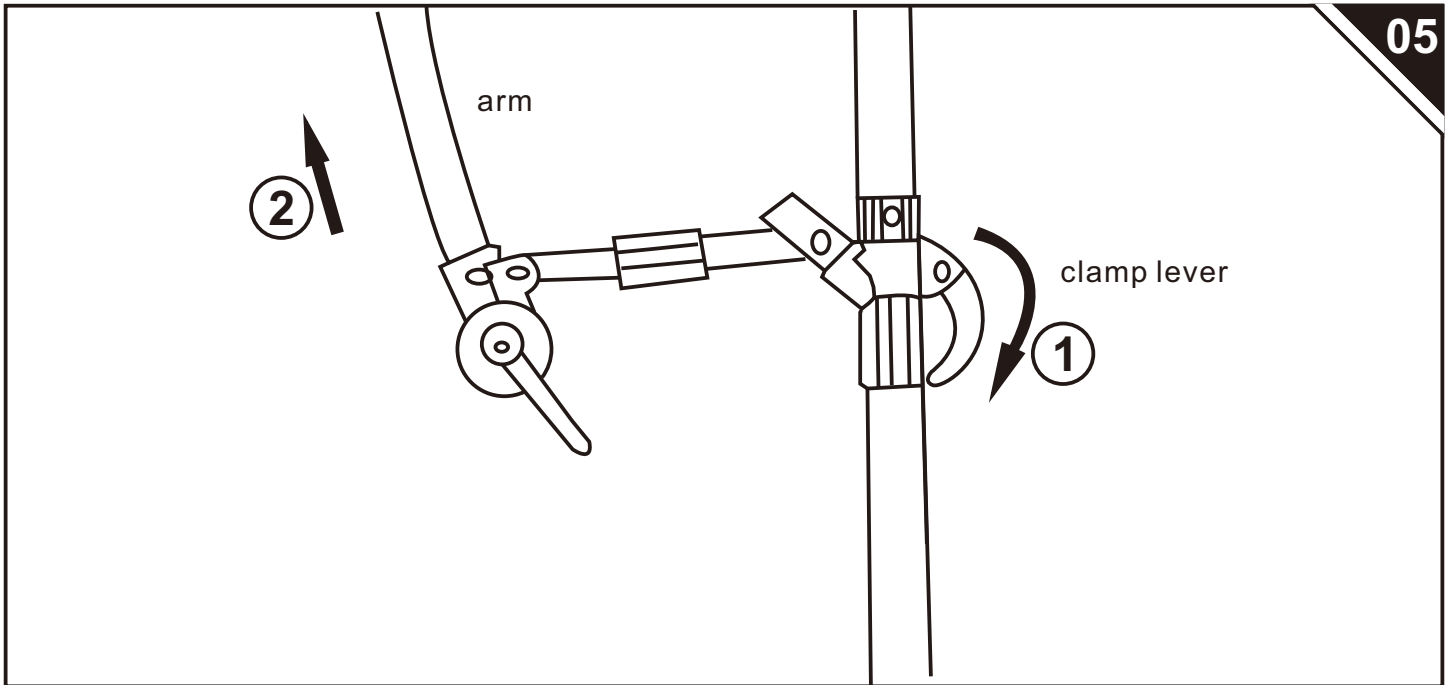
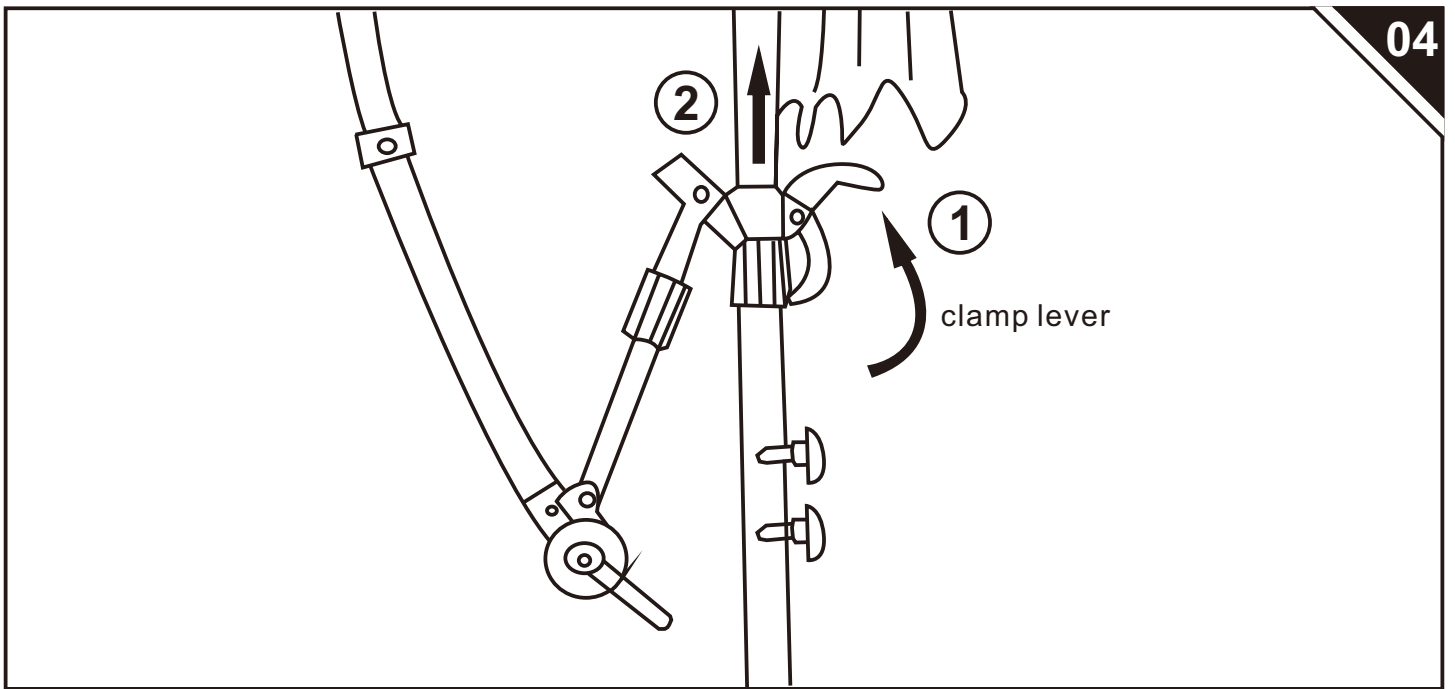

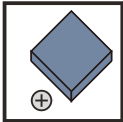
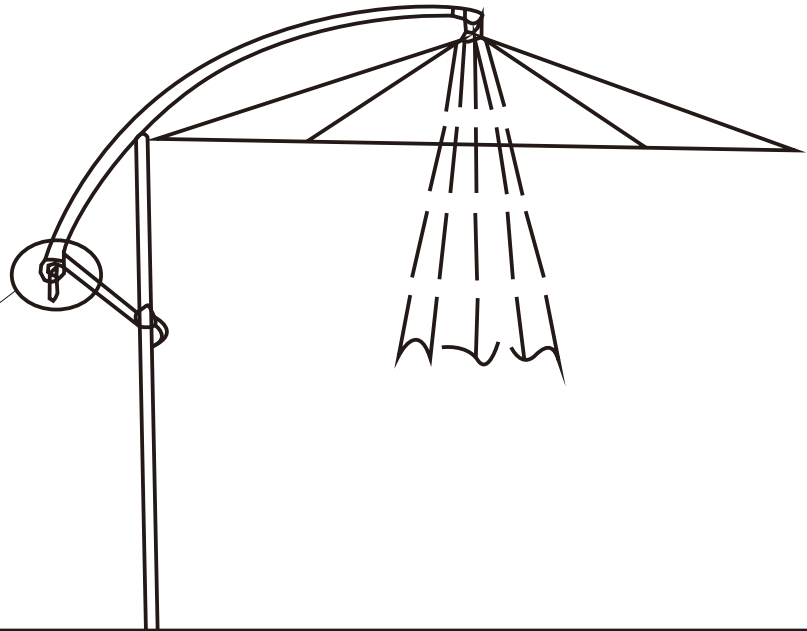
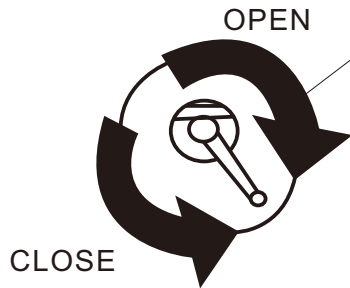

**NOT INCLUDED**

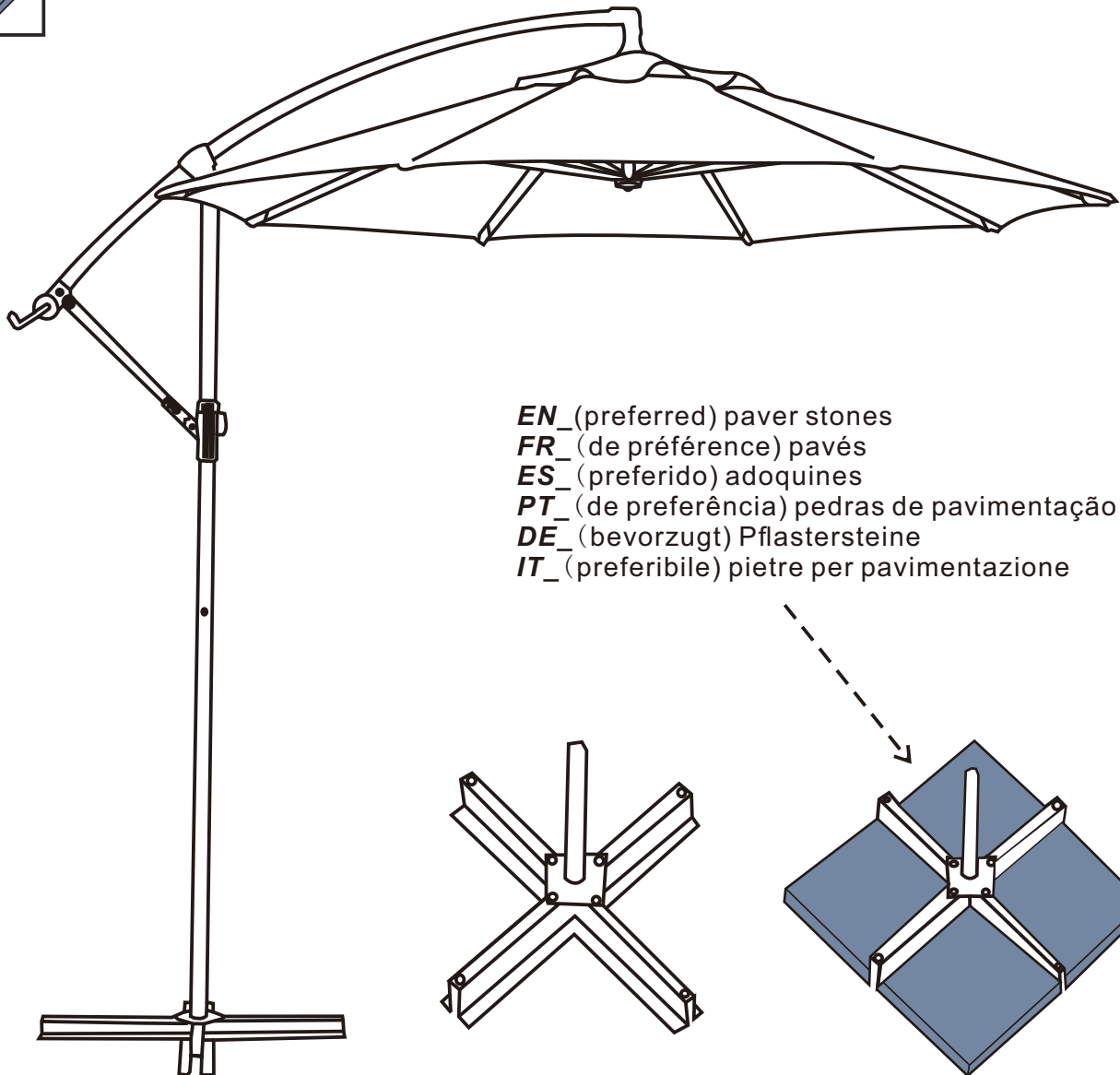

OPEN

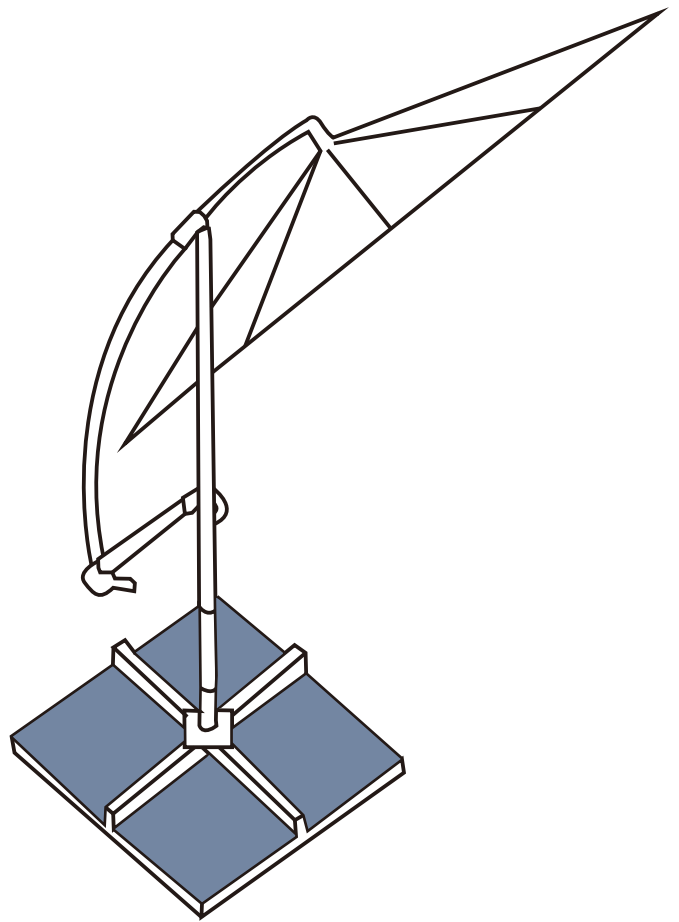
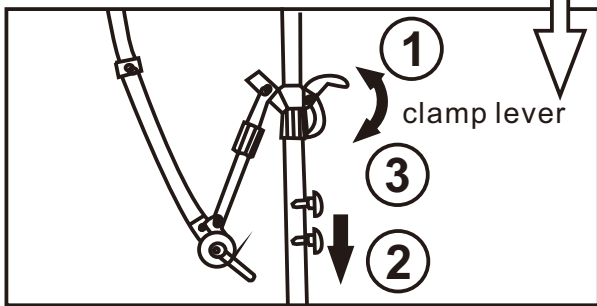
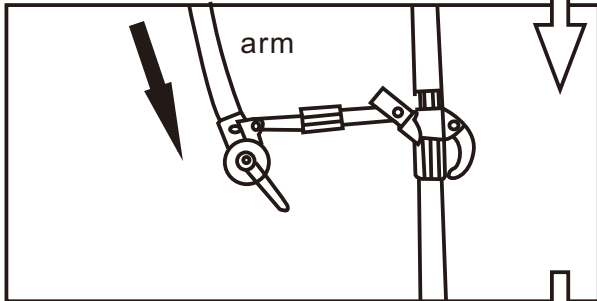
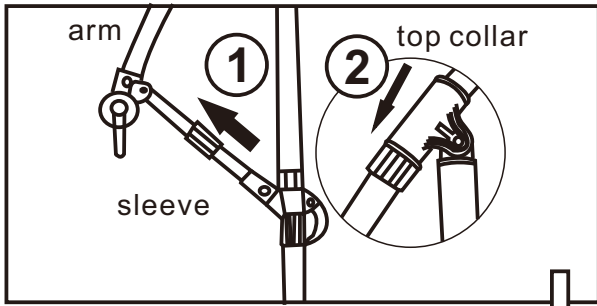

CLOSE

