

MANUAL RIO SET

**USER MANUAL | MODE D'EMPLOI | MANUAL DEL USUARIO | MONTAGEANLEITUNG |
MONTAGEHANDLEIDING | MANUALE PER L'UTENTE | MANUAL DO UTILIZADOR**

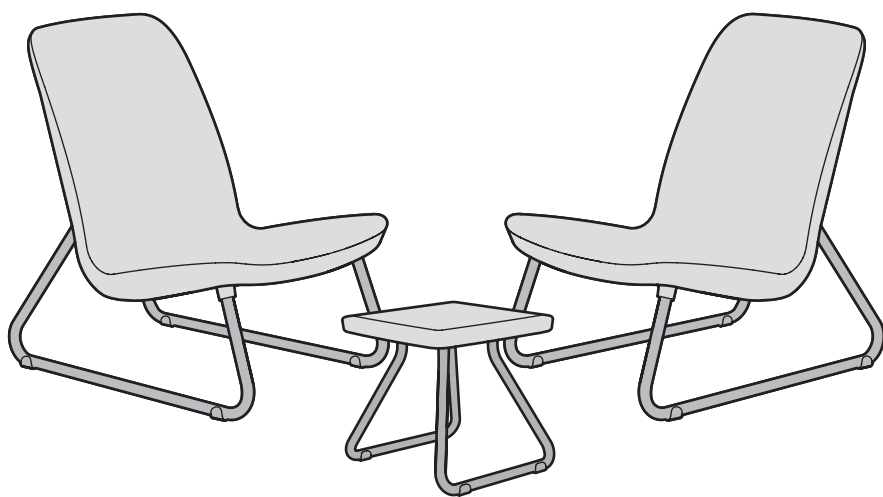



Attention - instructions to be kept for further reference. | Position in a stable way on a flat ground. | Spare parts not available beyond guarantee. | For domestic use. | For outdoor use. | Care Instructions. Use only neutral soap and a wet cloth to clean.

Important - a conserver pour une consultation ultérieure, à lire attentivement. | Positionner de manière stable sur un sol plan. | Pièces détachées non disponibles hors garantie. | Pour un usage domestique. | Pour un usage extérieur. | Notice d'entretien. N'utilisez que du savon neutre et un chiffon humide pour nettoyer.

Atención - guardar las instrucciones para futura referencia. | Colocar en una posición estable sobre terreno llano. | Piezas de repuesto no disponibles finalizada la garantía. | Para uso doméstico. | Para uso en exteriores. | Instrucciones de Mantenimiento. Lavar con un trapo humedecido y jabón neutro.

Achtung - anleitung soll als zukünftige referenz aufbewahrt werden. | Stabil auf ebenem Boden aufstellen. | Ersatzteile nach auslaufen der garantie nicht erhältlich. | Für den Hausgebrauch. | Für die Verwendung im Freien. | Pflegehinweis. Zur Reinigung bitte nur PH-neutrale Seife und ein feuchtes Tuch verwenden.

Let op - instructies moeten voor toekomstige raadpleging worden bewaard. | Plaats op stabiele wijze op een vlakke ondergrond. | Reserveonderdelen zijn niet verkrijgbaar na de garantieperiode. | Voor huishoudelijk gebruik. | Voor gebruik buiten. | Onderhoudsinstructies. Gebruik alleen neutrale zeep en een vochtige doek om te reinigen.

Attenzione: le istruzioni devono essere conservate con cura per riferimenti futuri. | Posizionare in maniera stabile o su un terreno piano. | Pezzi di ricambio non disponibili superato il periodo di garanzia. | Per uso domestico. | Per uso all'esterno. | Istruzioni per la cura del prodotto. Utilizzare un sapone neutro e pulire con un panno umido.

Atenção - as instruções devem ser guardadas para referência futura. | Posicionar numa forma estável num piso plano. | As peças sobressalentes não estão disponíveis além da garantia. | Para uso doméstico. | Para uso ao ar livre. | Instruções de uso. Utilize um pano húmido e um sabão neutro.

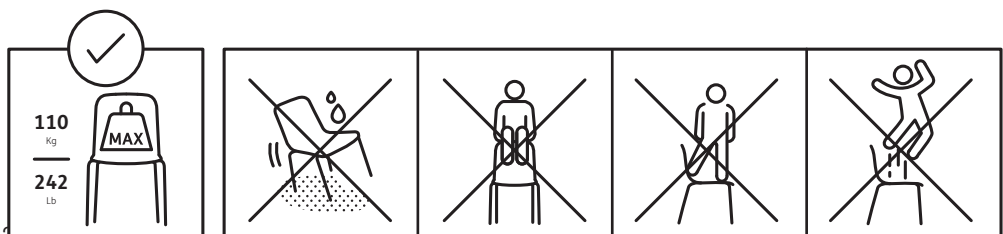

ASSEMBLY PARTS | PIÈCES À ASSEMBLER | PIEZAS DE ENSAMBLE | MONTAGETEILE | PARTI DA MONTA RE | ONDERDELEN | PEÇAS DE MONTAGEM

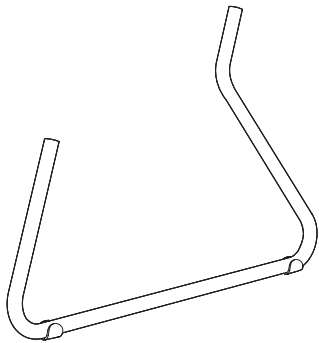

(x4)

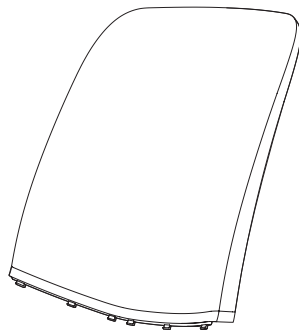

B (x2)

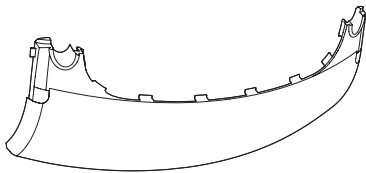

BC (x2)

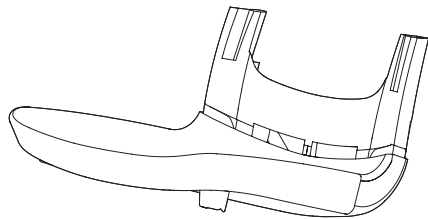

S (x2)

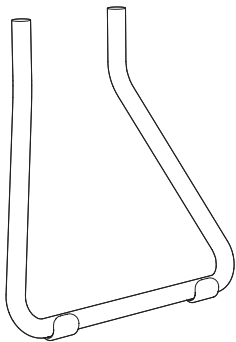

(x2)



TT (x1)

x2

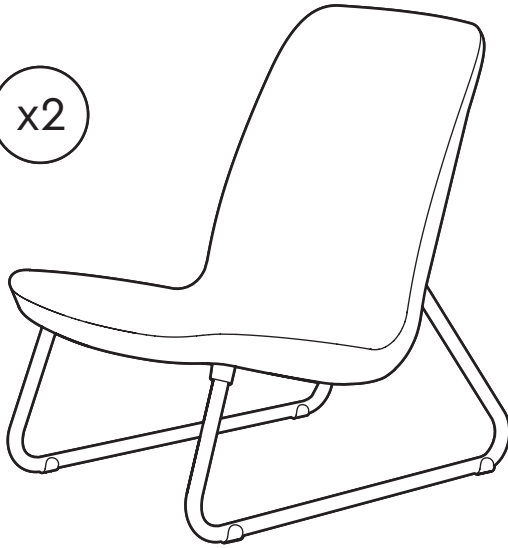

1

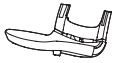

S (x1)



(x2)

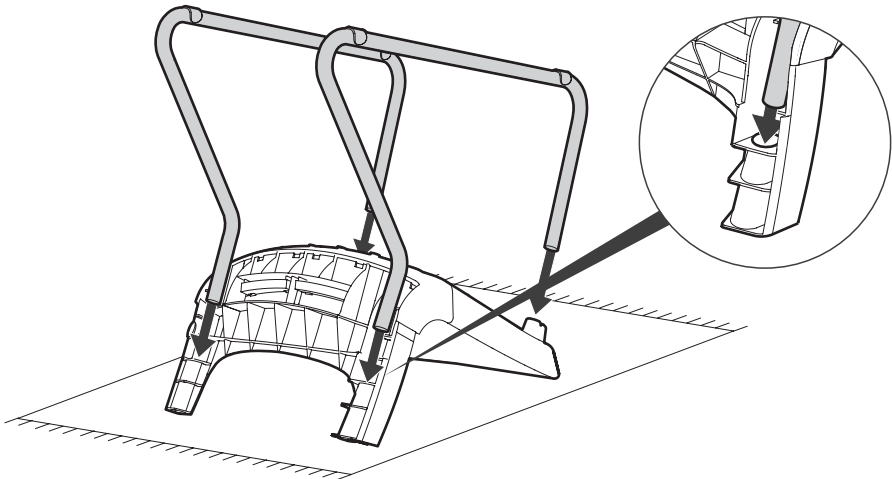

2



B (x1)

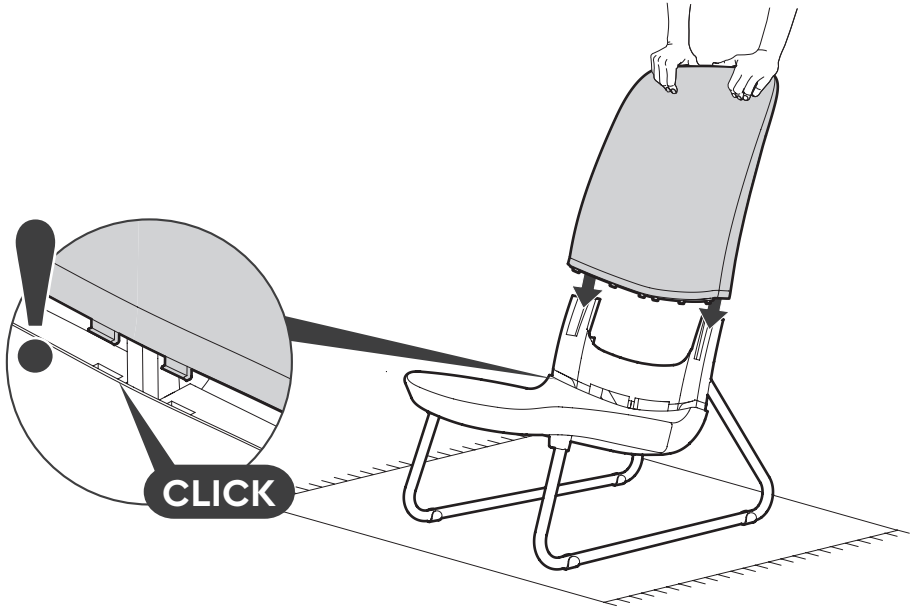

3



BC (x1)

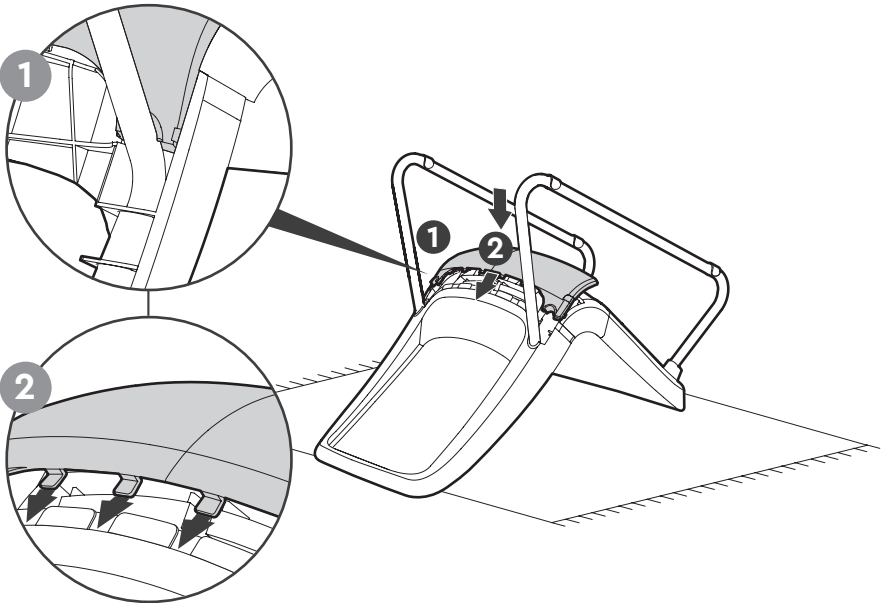

4

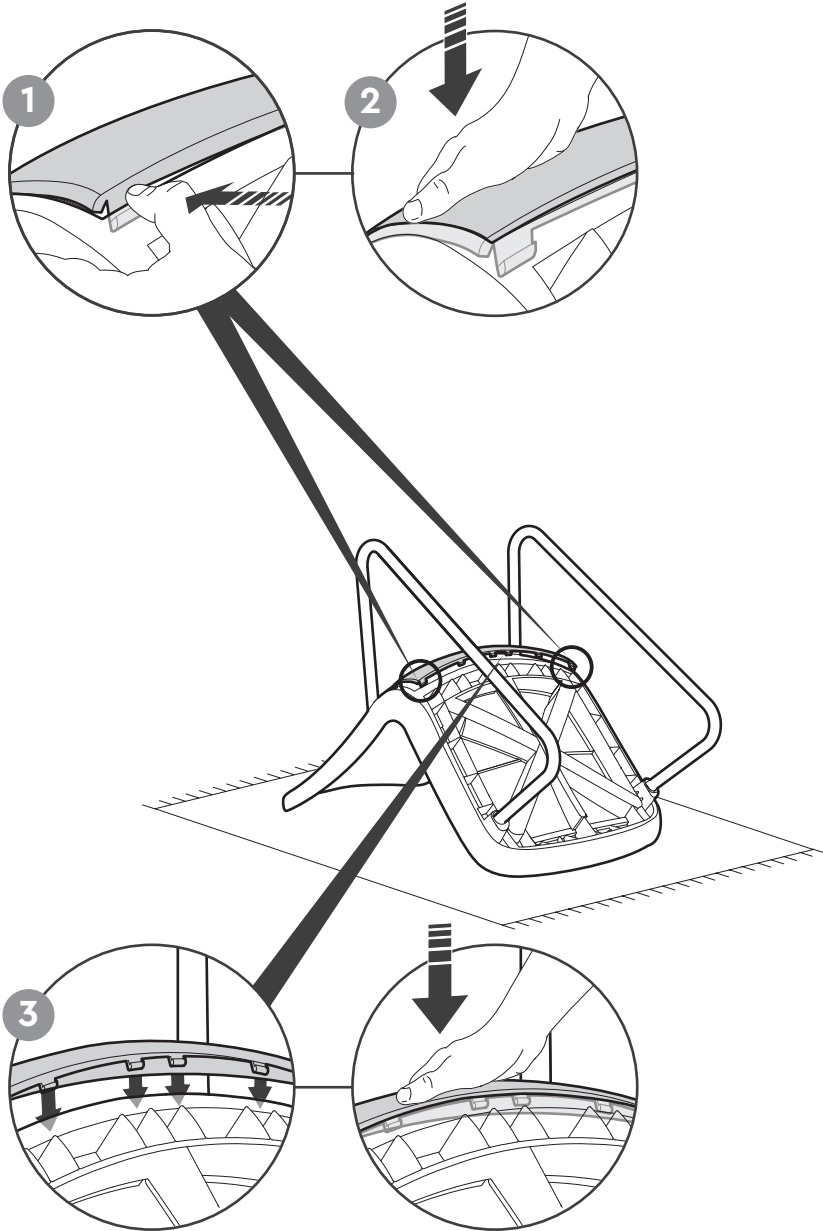



1



TT(x1)



(x2)

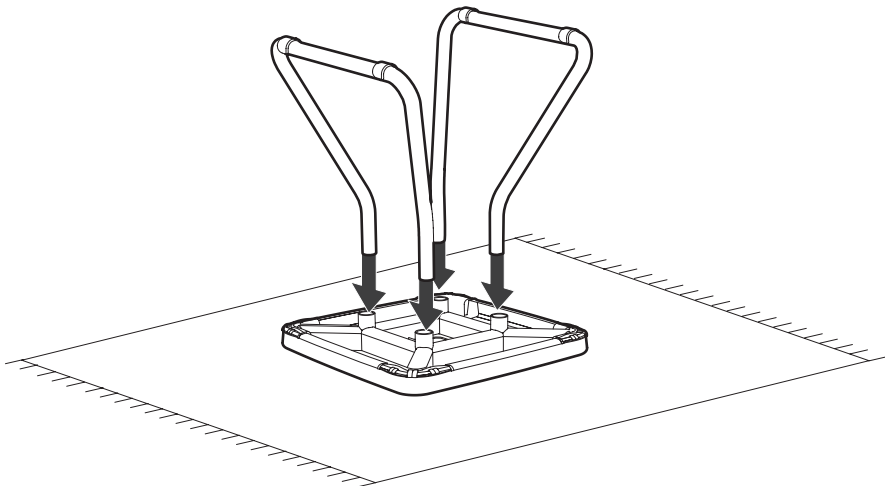



For any assistance, please contact customer service.

Pour toute assistance, veuillez contacter notre service clientèle | **Para solicitar ayuda por favor, póngase en contacto con nuestro servicio al cliente** | Bitte kontaktieren Sie unseren Kundenservice, falls Sie Hilfe benötigen | **Voor ondersteuning, gaarne contact opnemen met onze klantendienst** | Per qualsiasi tipo di assistenza, potete contattare il nostro servizio clienti | **Para obter assistência, favor contatar nosso atendimento ao cliente em.**

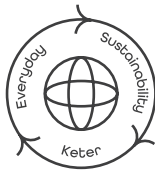

Designed to Last | Conçu pour durer | Diseñado para durar | Auf Langlebigkeit ausgelegt | Duurzaam ontworpen | Progettato per durare | Projetado para durar



Community | Communauté | Comunidad | Community | Community | Comunità | Comunidade



Recyclability & Recycling | Recyclabilité et Recyclage | Reciclabilidad y reciclable | recyclefähig & recycelt | Recyclebaarheid & recycling | Riciclabilità e Riciclo | Reciclabilidade e Reciclagem



Responsible Manufacturing | Fabrication responsable | Producción responsable | Verantwortungsbewusste Herstellung | Verantwoorde productie | Produção responsável | Fabricação responsável