

DJ504498
GJ-011-T

Version: 1.0

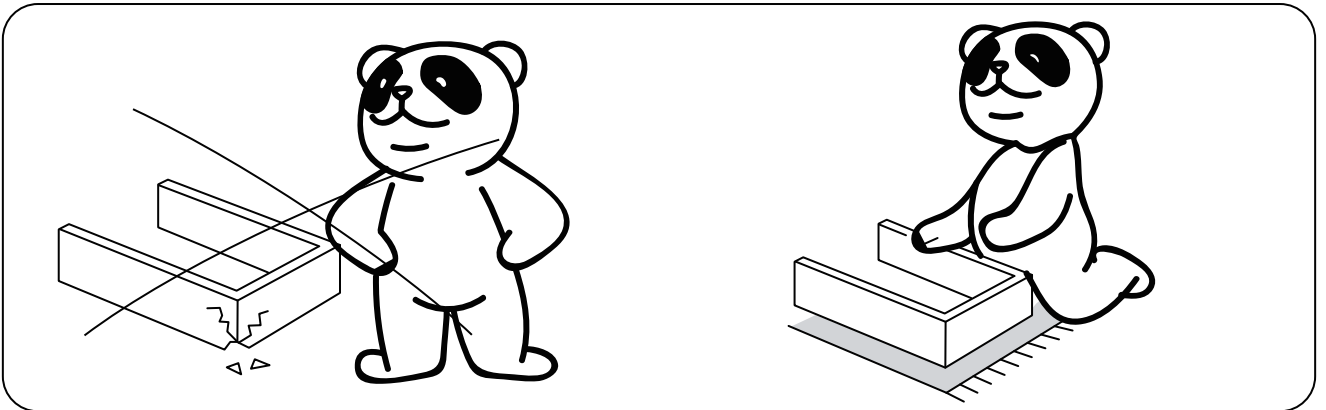

Violent installation is prohibited

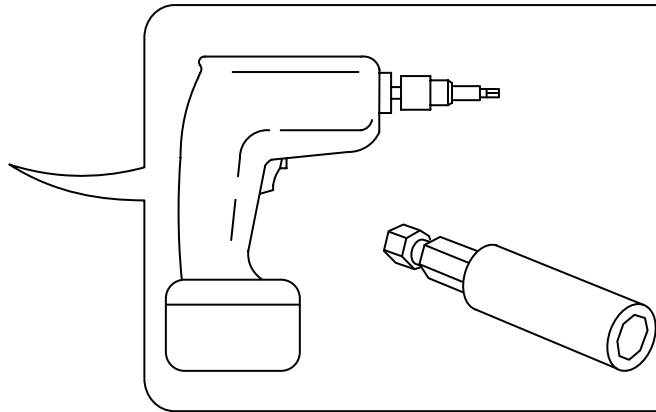
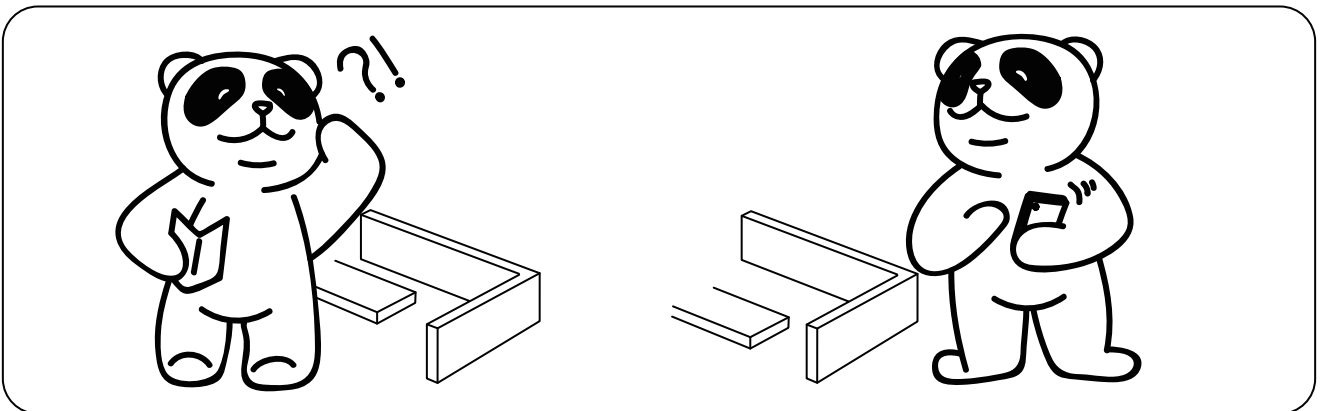

Please call if you need help

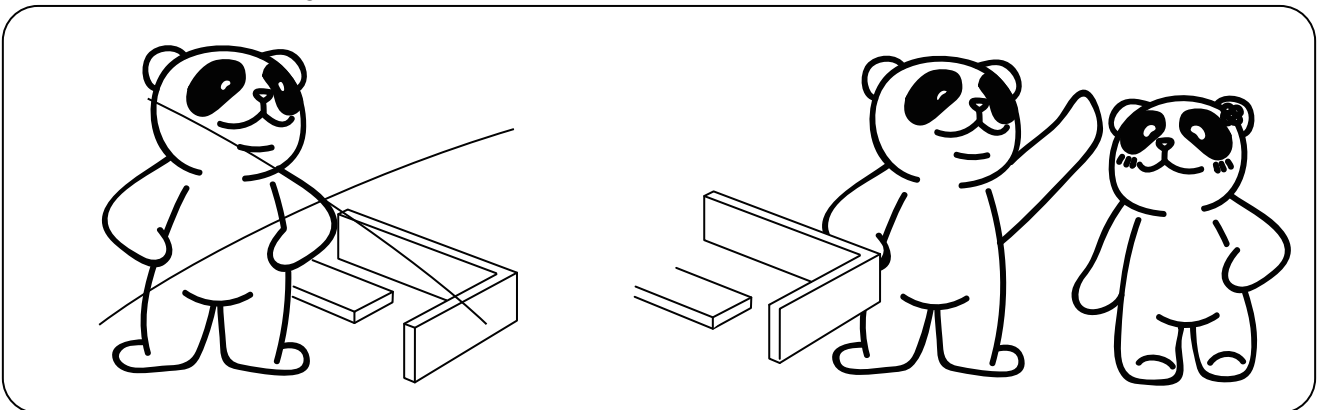

Multi-person cooperation is recommended

Assembly Instruction

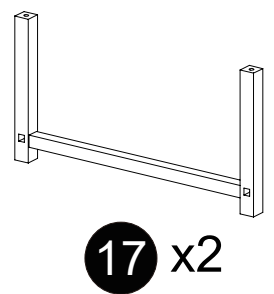
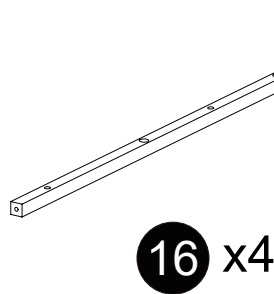
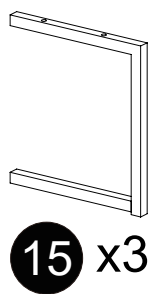
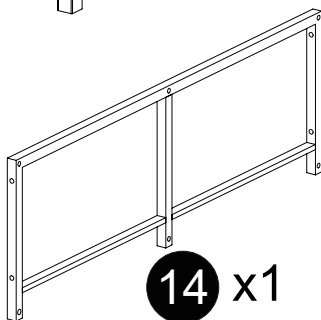
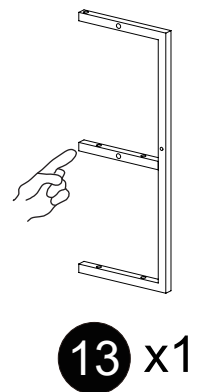
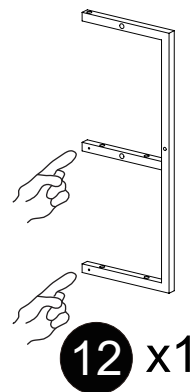
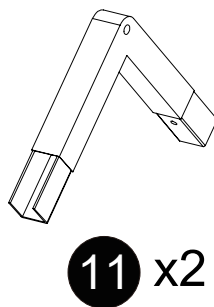
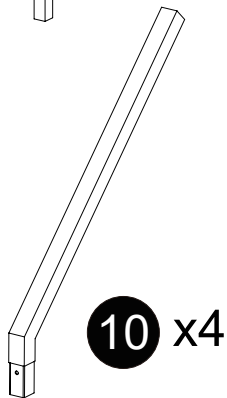
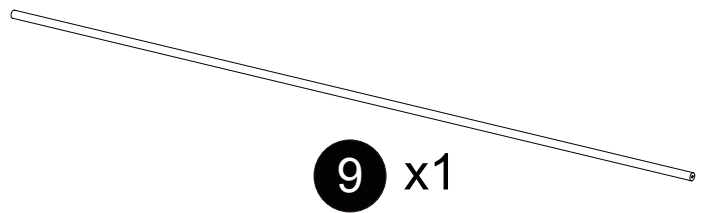
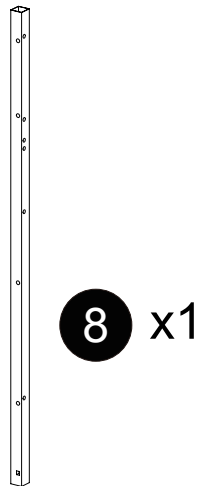
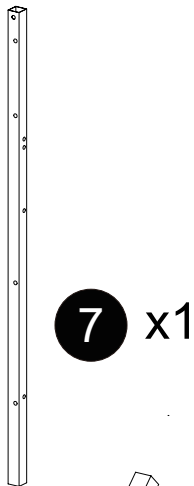
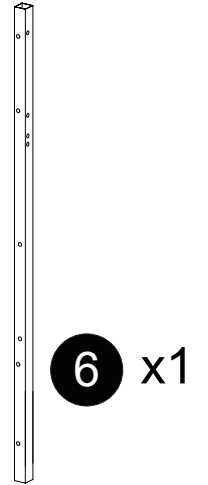
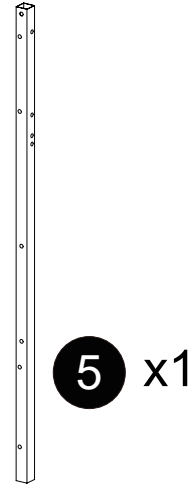
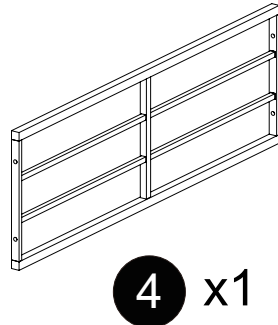
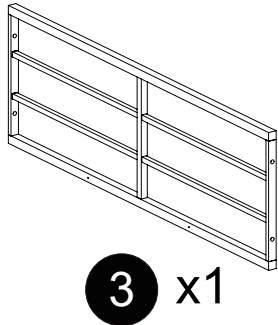
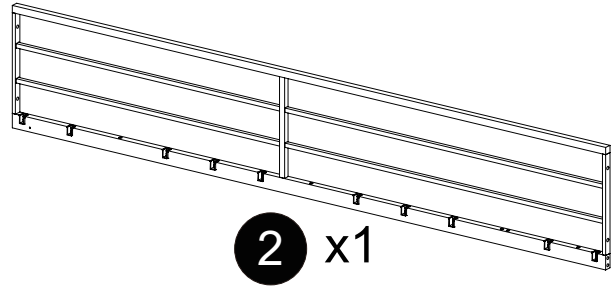
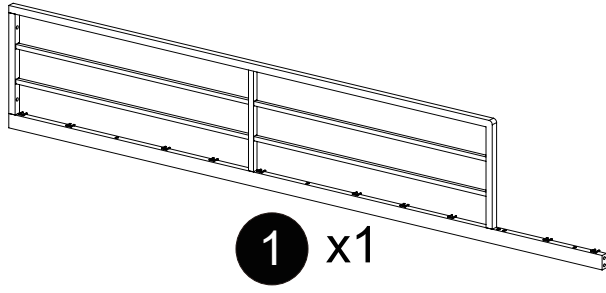

Assembly Instruction

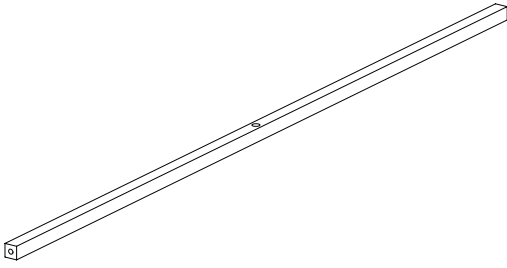

18 x1

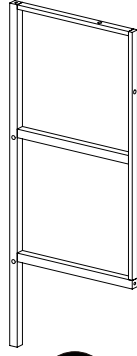

19 x1

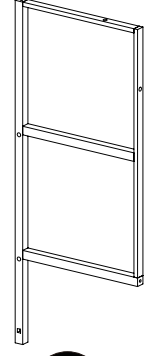

20 x1

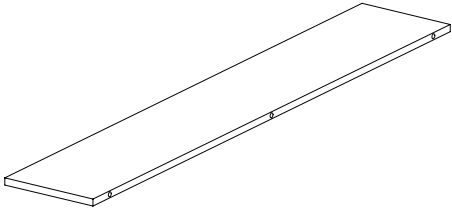

21 x1

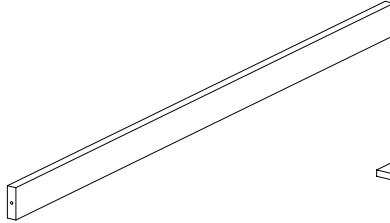

22 x1

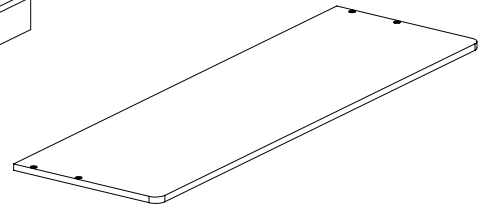

23 x1

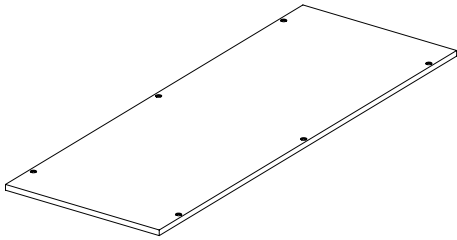

24 x2

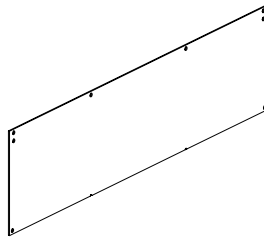

25 x1

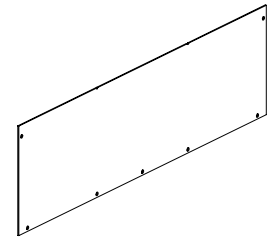

26 x1

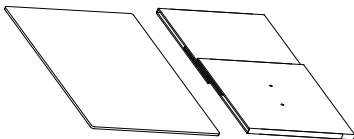

27 x3

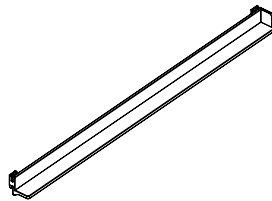

28 x3

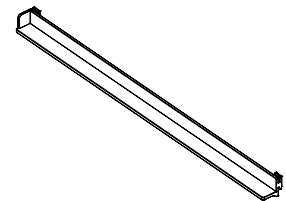

29 x3

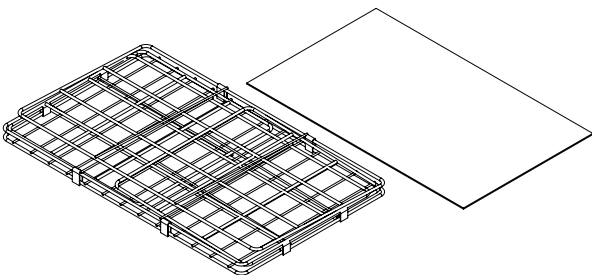

30 x2

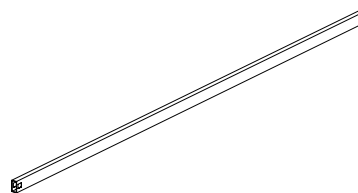

31 x10

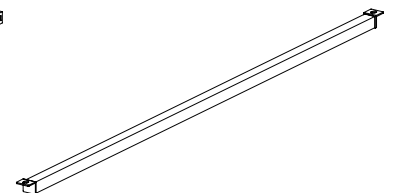

32 x3

Assembly Instruction

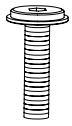

A

M8*55

X8+1

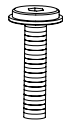

B

M6*55

X2+1

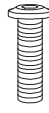

C

M6*40

X16+1



D

M6*32

X6+1



E

M6*20

X28+2



F

M6*32

X15+1



G

M3

X1



H

M4

X2

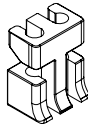

J

X8+1



K

M4*10

X6+1



L

M6*28

X26+1



M

X3+1



N

M5

X1

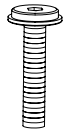

O

M6*45

X16+1



P

X3+1



Q

M6*18

X8+1



R

M6*10

X8+1

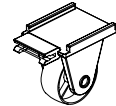

S

X8



T

X3



U

M6*25

X9+2



V

M5*40

X6+1



W

X3

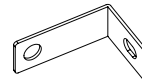

X

X2



Y

X1

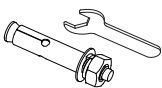

Z

X2



A1

X2+1



A2

X1

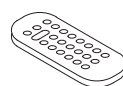

Remote control

A3

X1

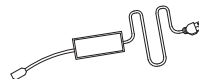

Power cord

A4

X1

Assembly Instruction

LED light strip electronic accessories list

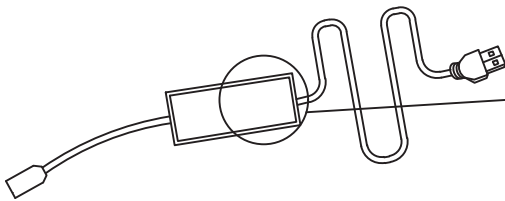

x1

Power cord



There is a two-dimensional code at the position of the power line. Scanning can download the APP for the control light

Assembly Instruction

Note:

1. Should be assembled on flat ground to keep balance.
2. Before completing the installation, do not tighten the screws.

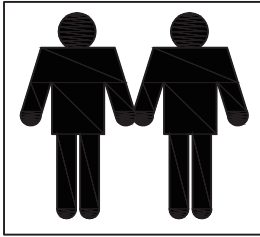

It needs at least two people to install !!



Before starting the assembly, you must read the whole manual and follow the instructions

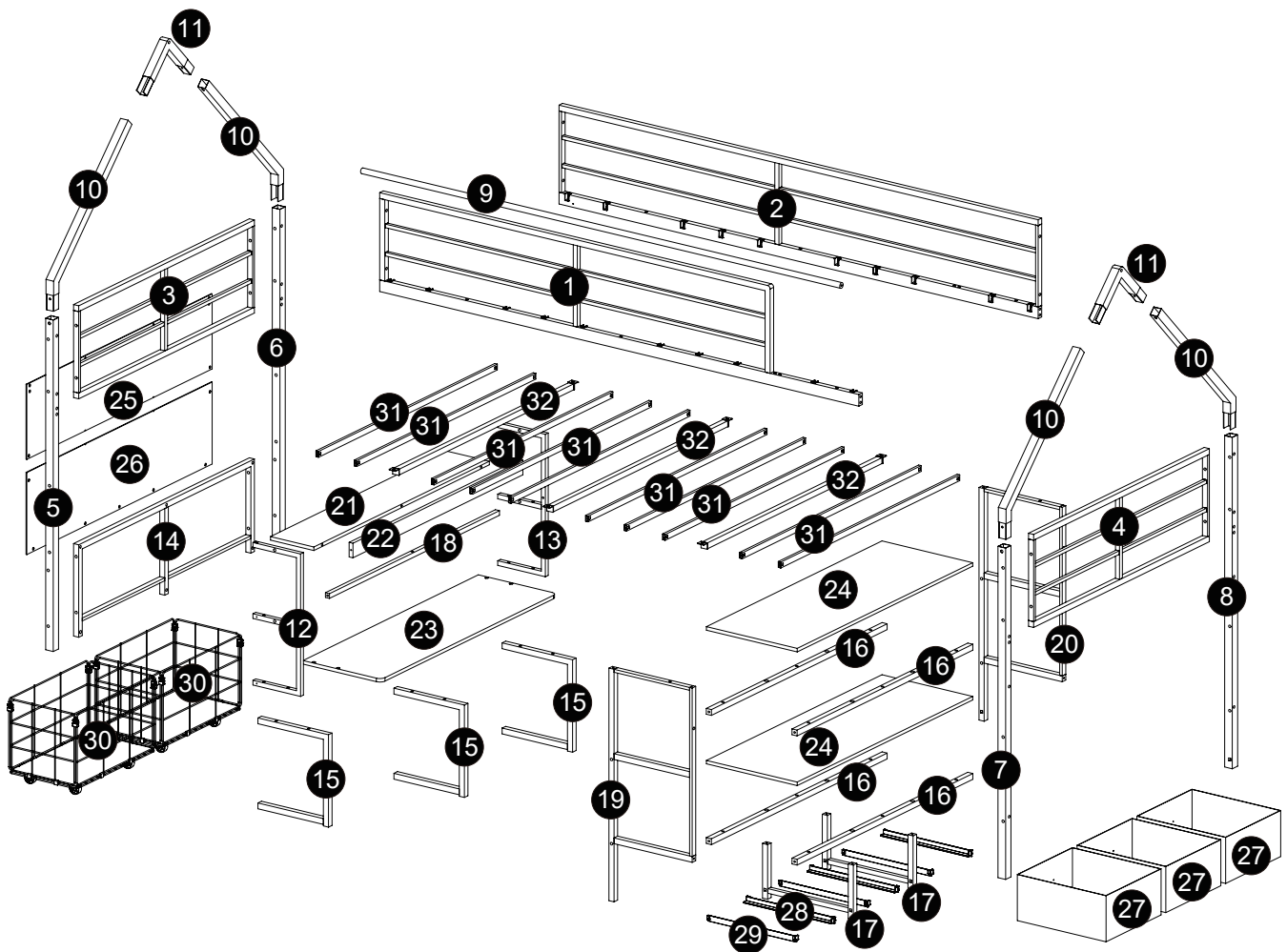

Assembly Instruction

1



Be careful not to overtighten the screws.

E M6*20



F M6*32

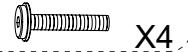

H M4

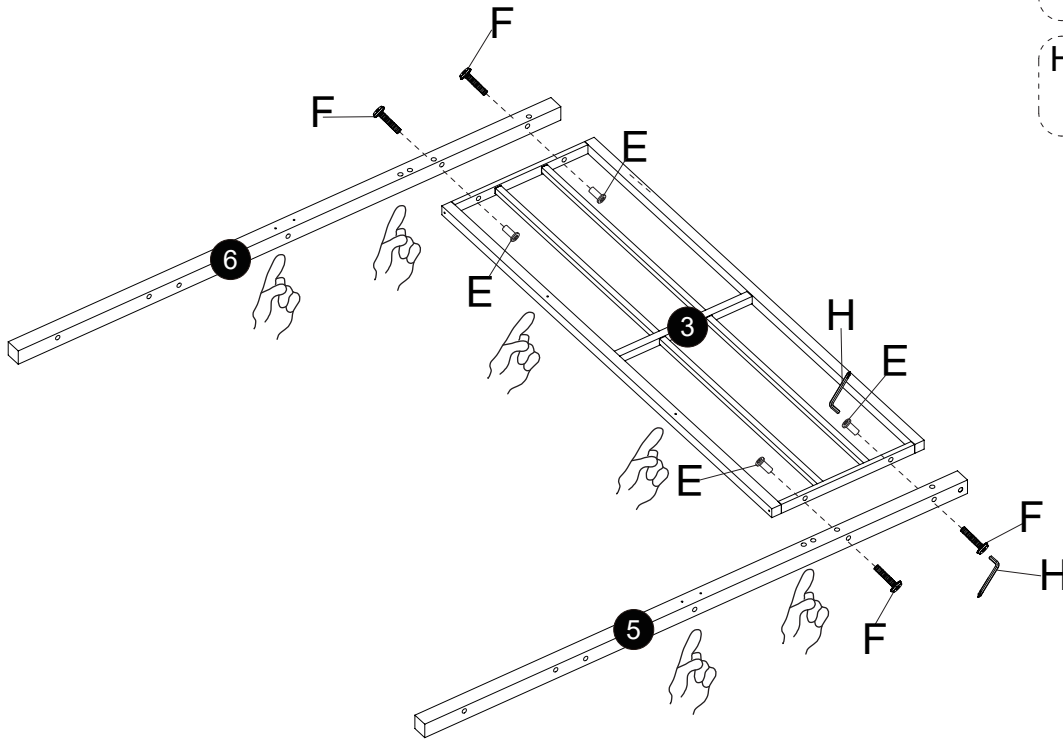

2

R M6*10



H M4

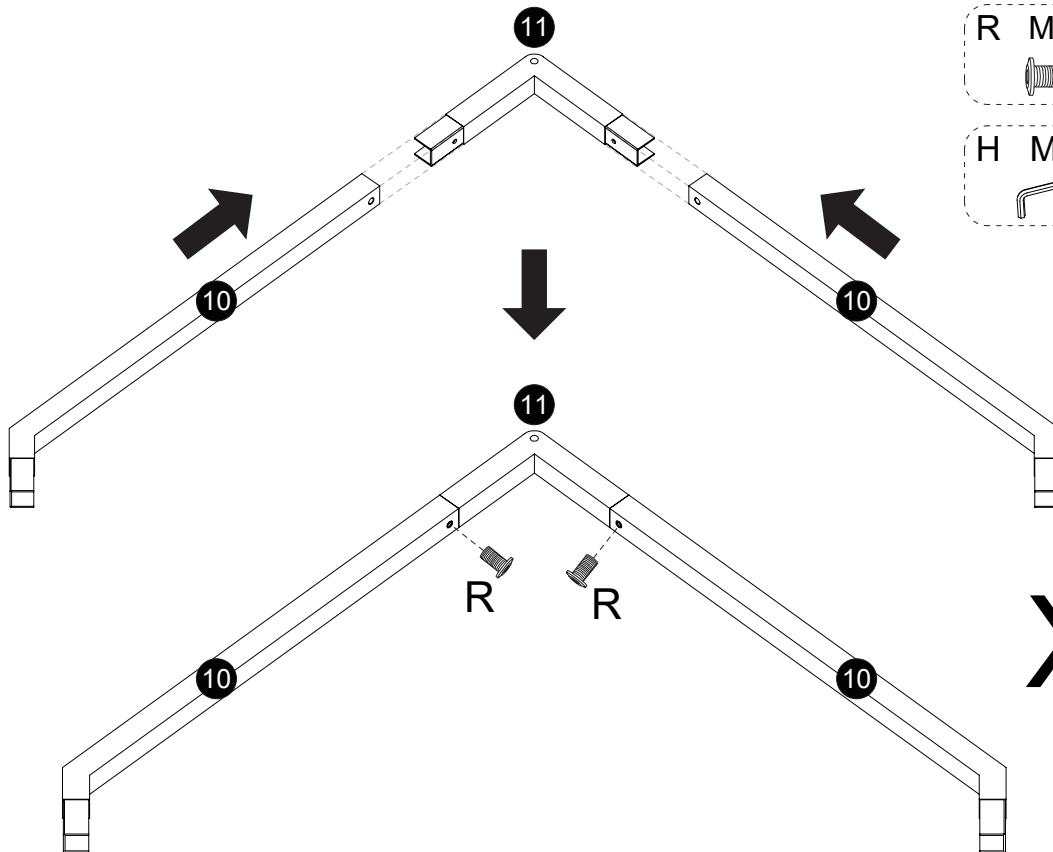

Assembly Instruction

5



Be careful not to overtighten the screws.

E M6*20



X1

F M6*32



X1

O M6*45



X1

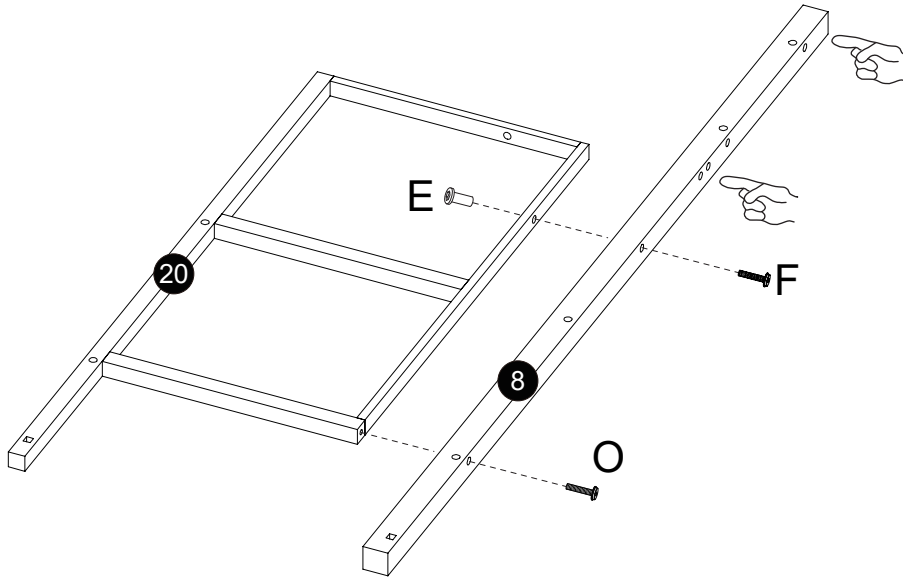

6

A M8*55



X2

B M6*55

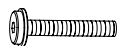

X1

E M6*20



X2

F M6*32

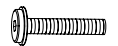

X1

O M6*45

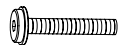

X1

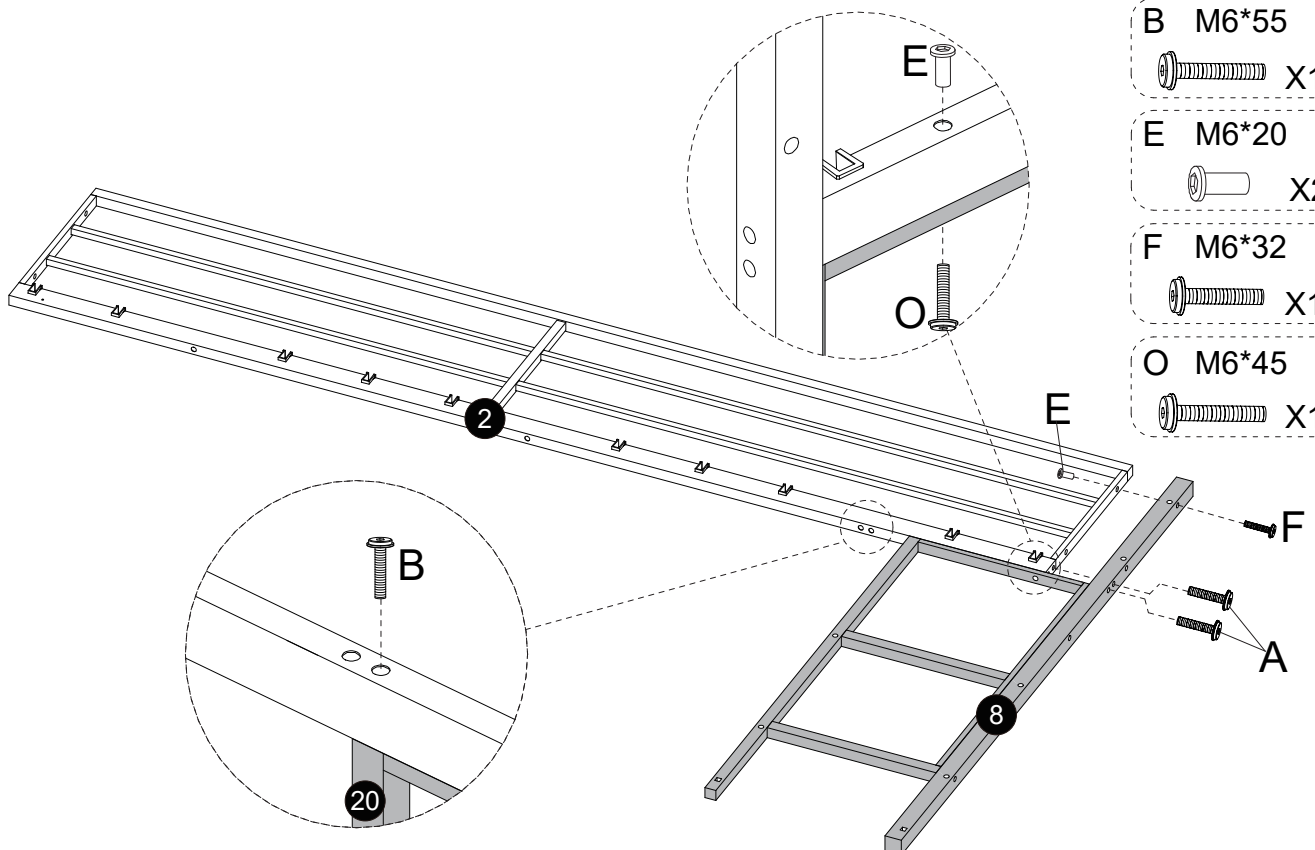

Assembly Instruction

7

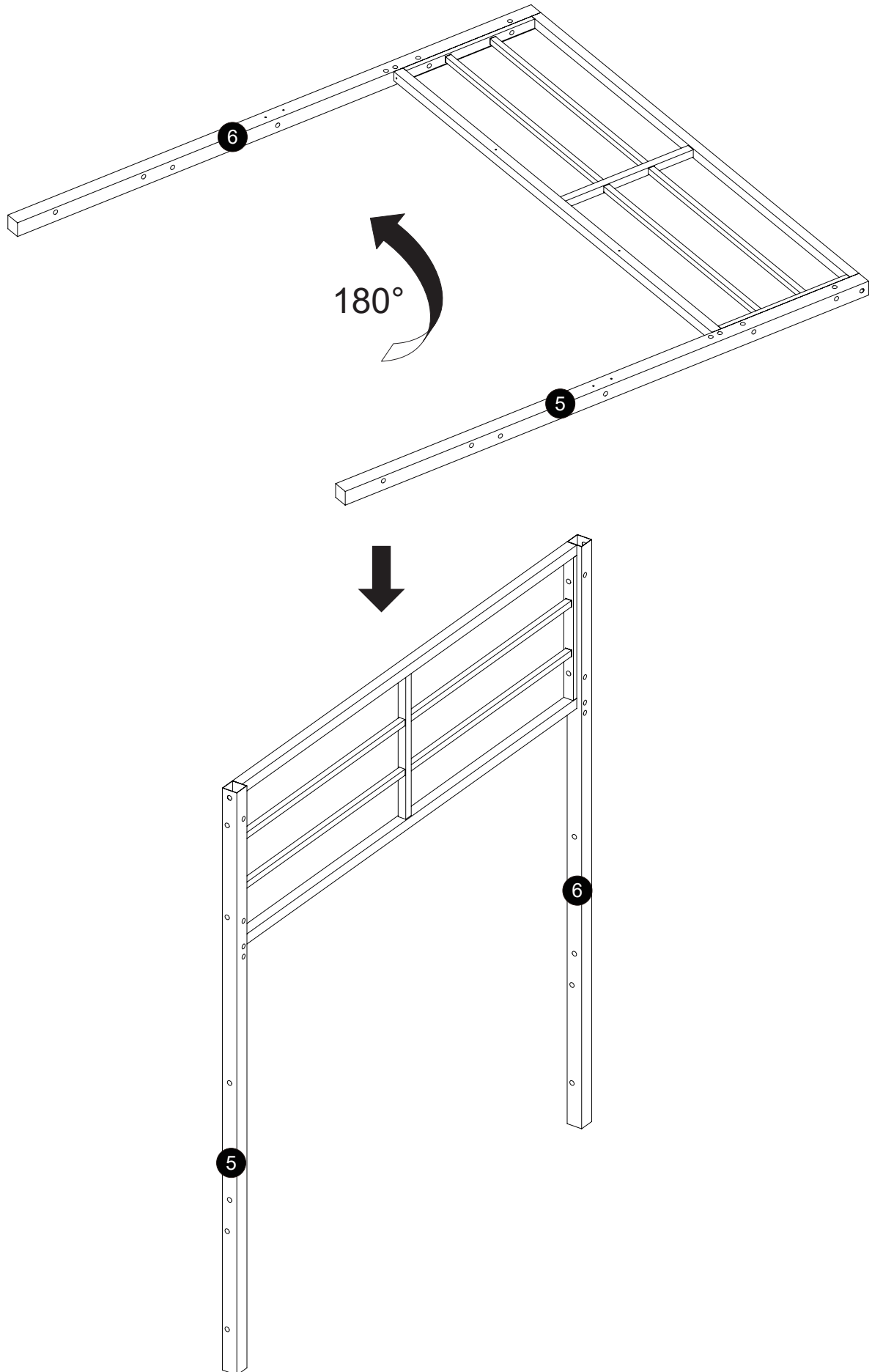

Assembly Instruction

8



Note the orientation of parts (5) and (6).

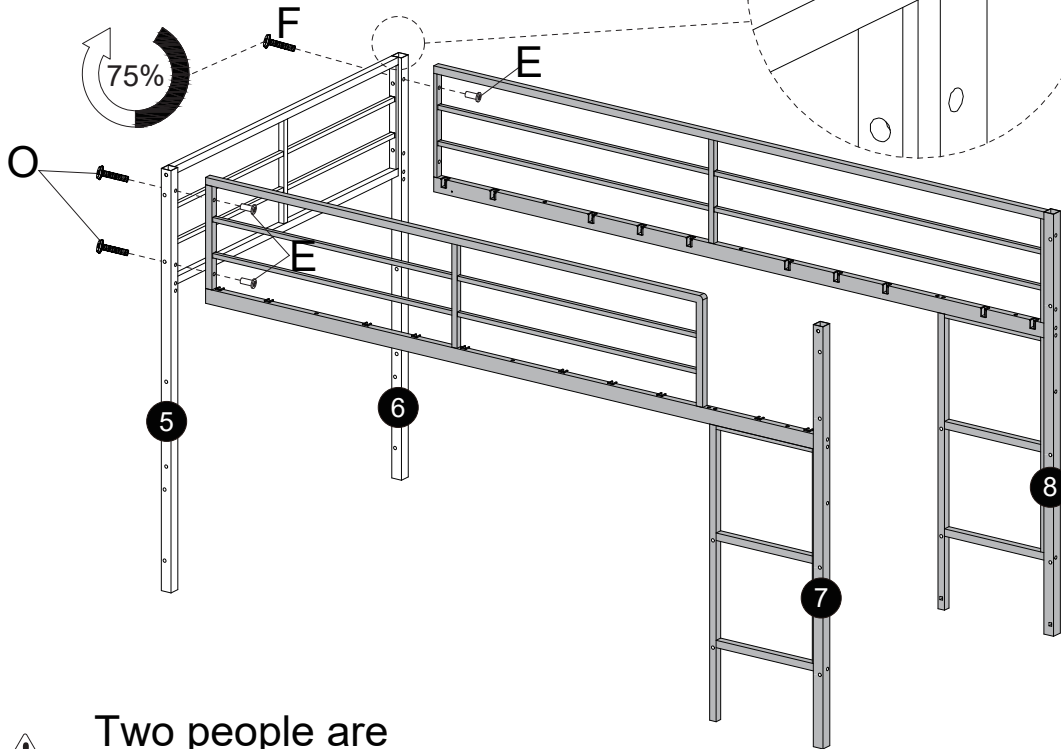

E M6*20



F M6*32



O M6*45



Two people are required to install.

9

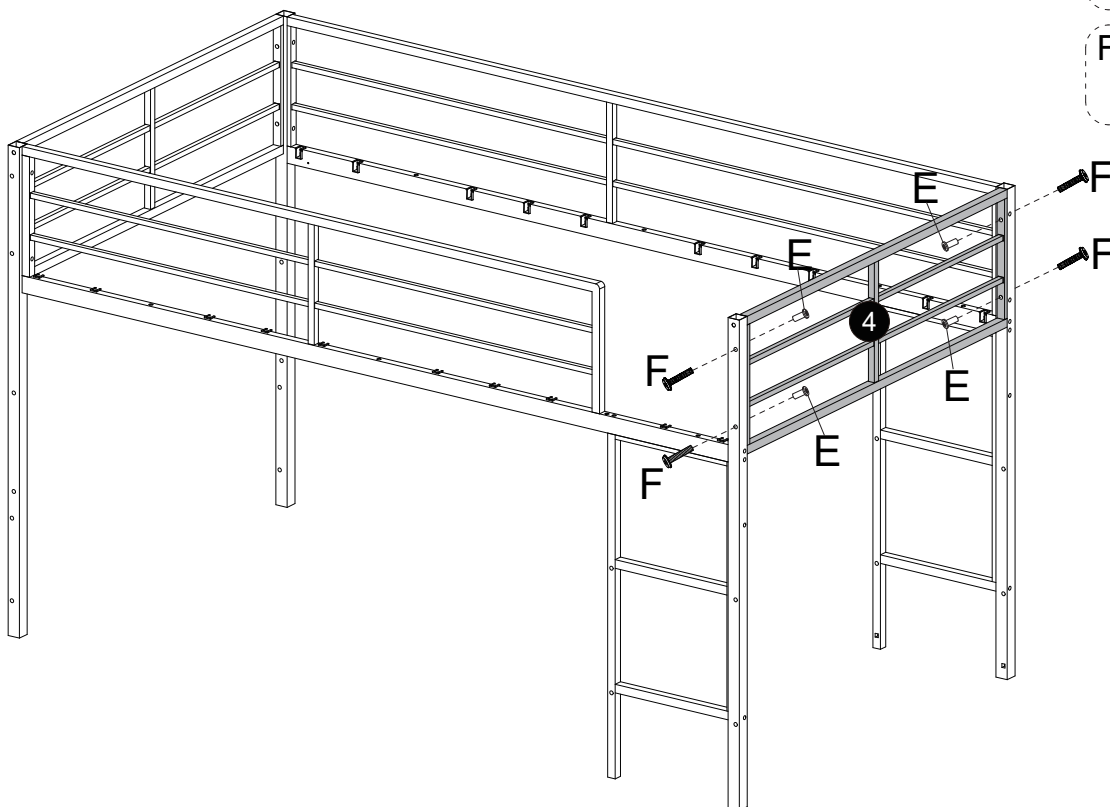

E M6*20





F M6*32

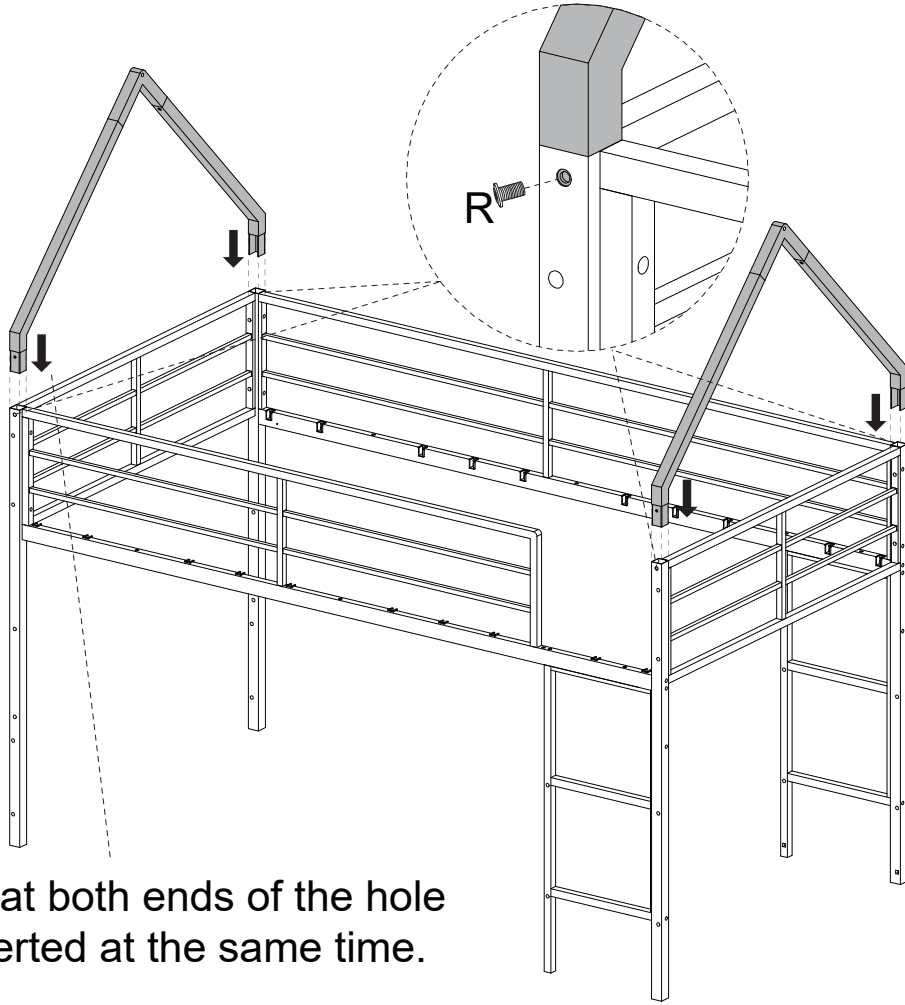

Assembly Instruction

10



R M6*10
 X4

H M4
 X1

Note that both ends of the hole are inserted at the same time.

11

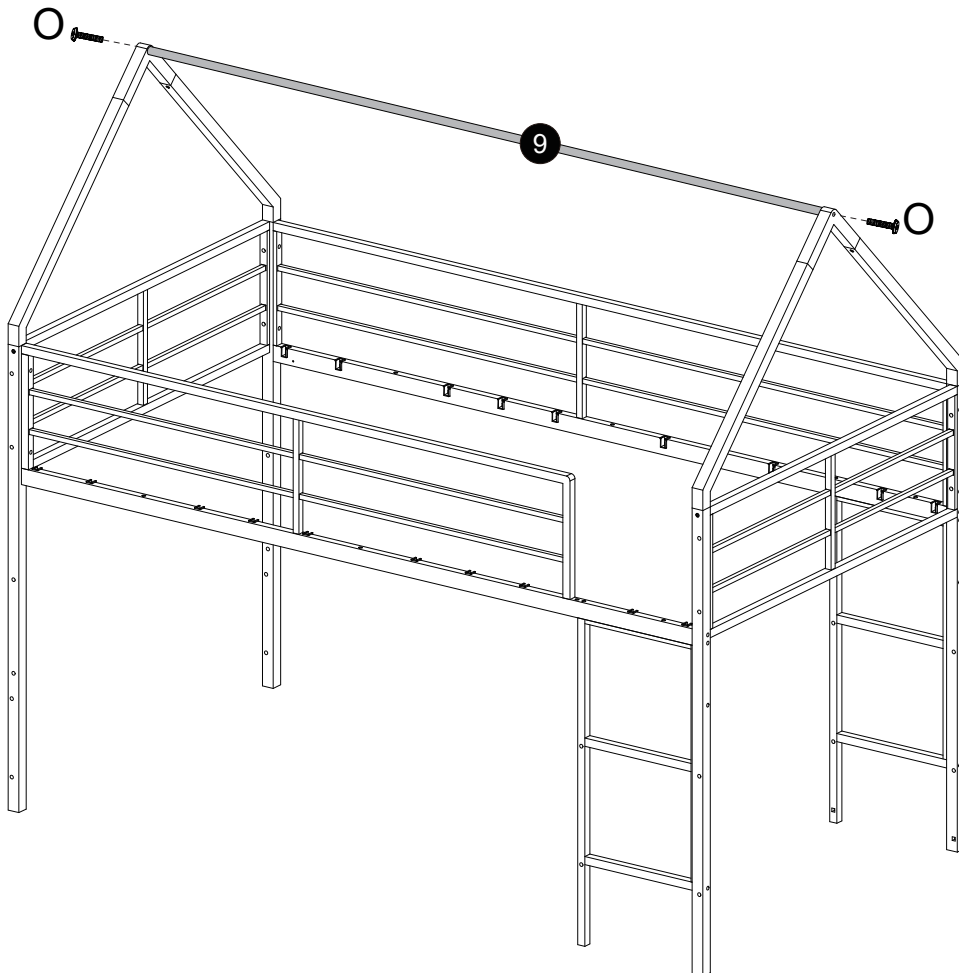

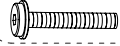
O M6*45
 X2

Assembly Instruction

12

The large hole of component (16) is facing forward.

L M6*28

X4

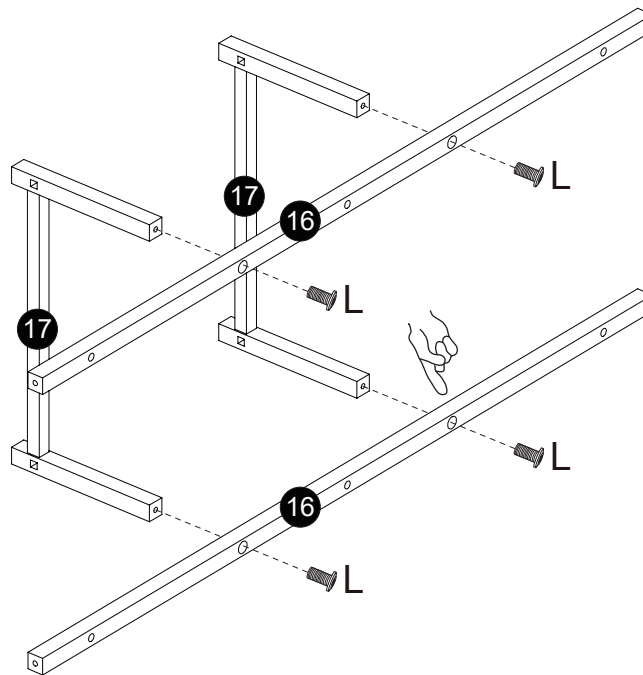

Pay attention to the alignment and re-locking of parts (16) and (17) when assembling to prevent the lock from being crooked.

13

The large hole of component (16) is facing upwards.

C M6*40

X4

O M6*45

X4

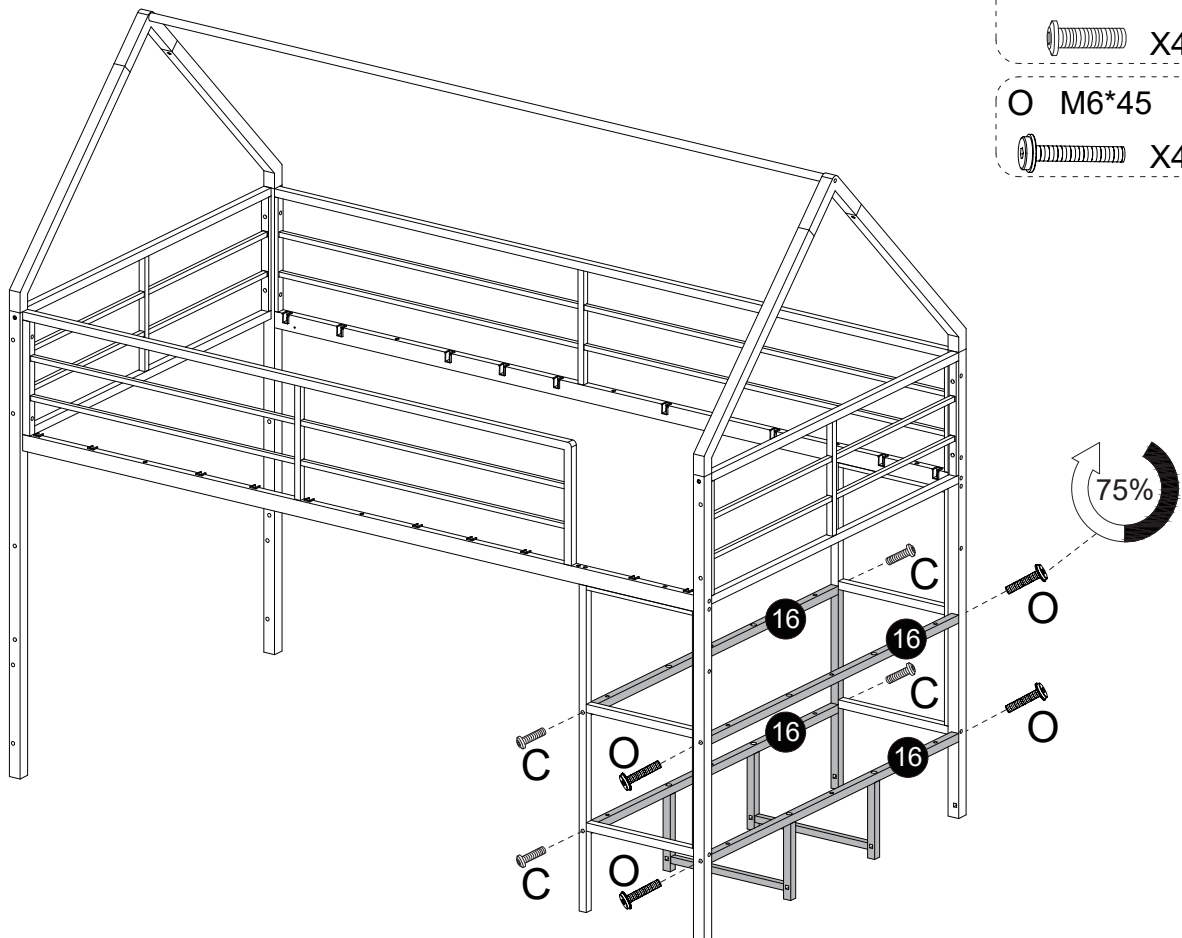

Assembly Instruction

14

C M6*40
 X3

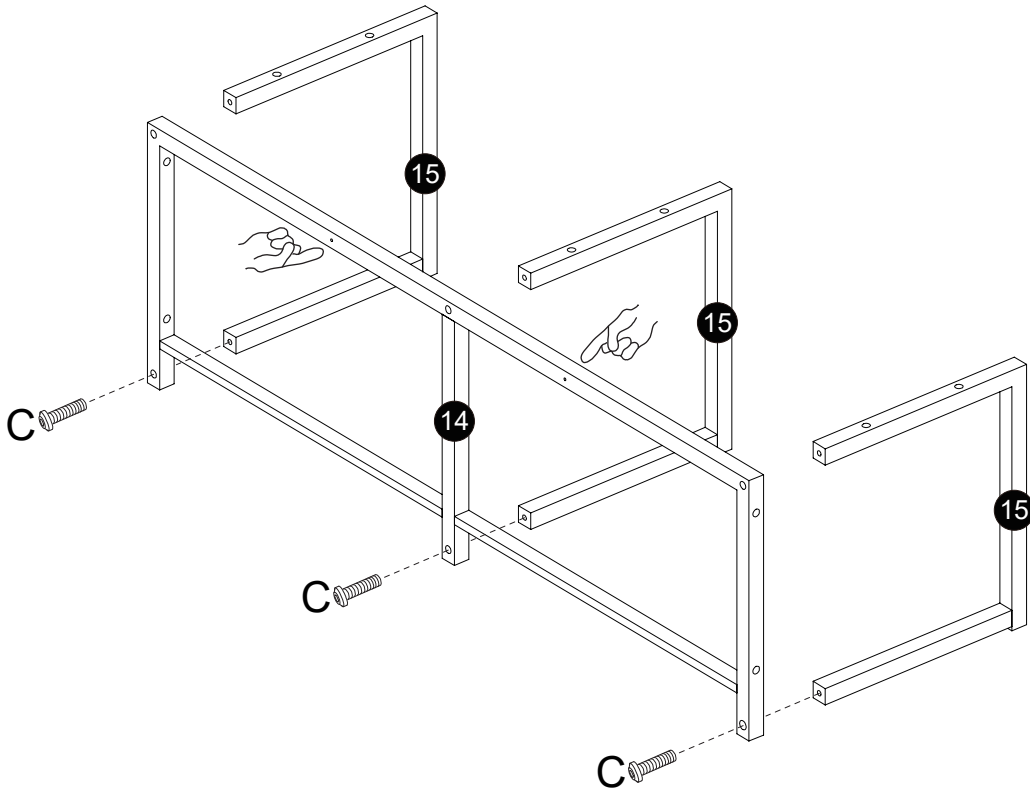

15

L M6*28
 X6

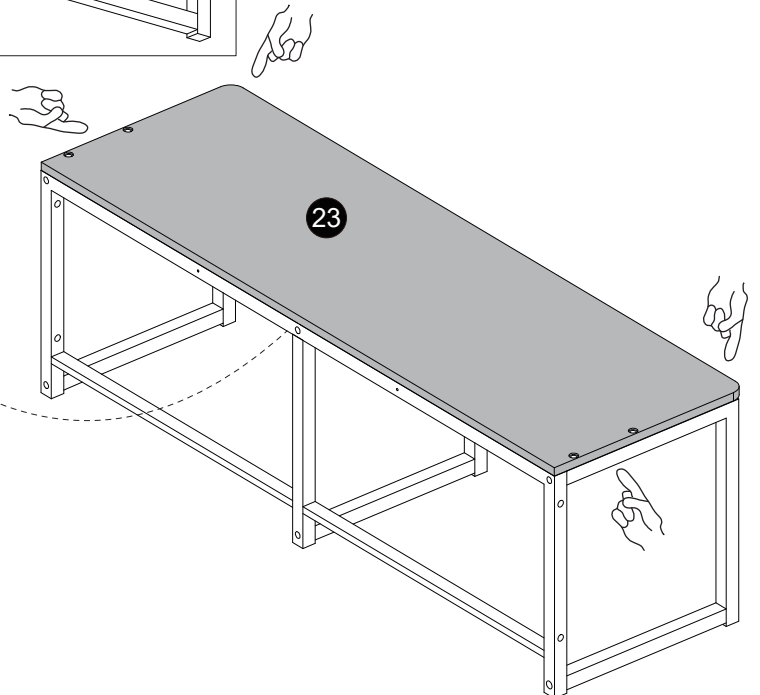
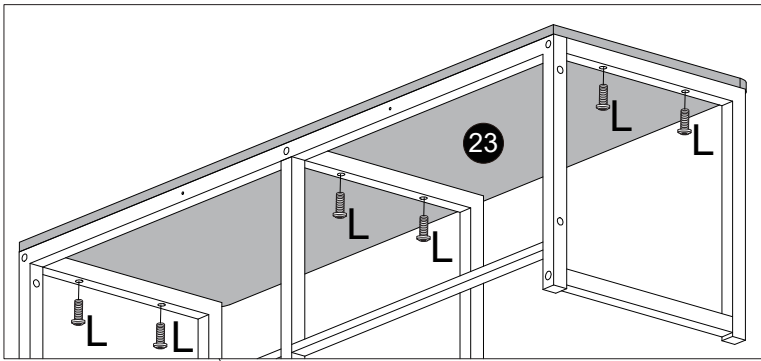

Assembly Instruction

16

- E M6*20 X4
- O M6*45 X4

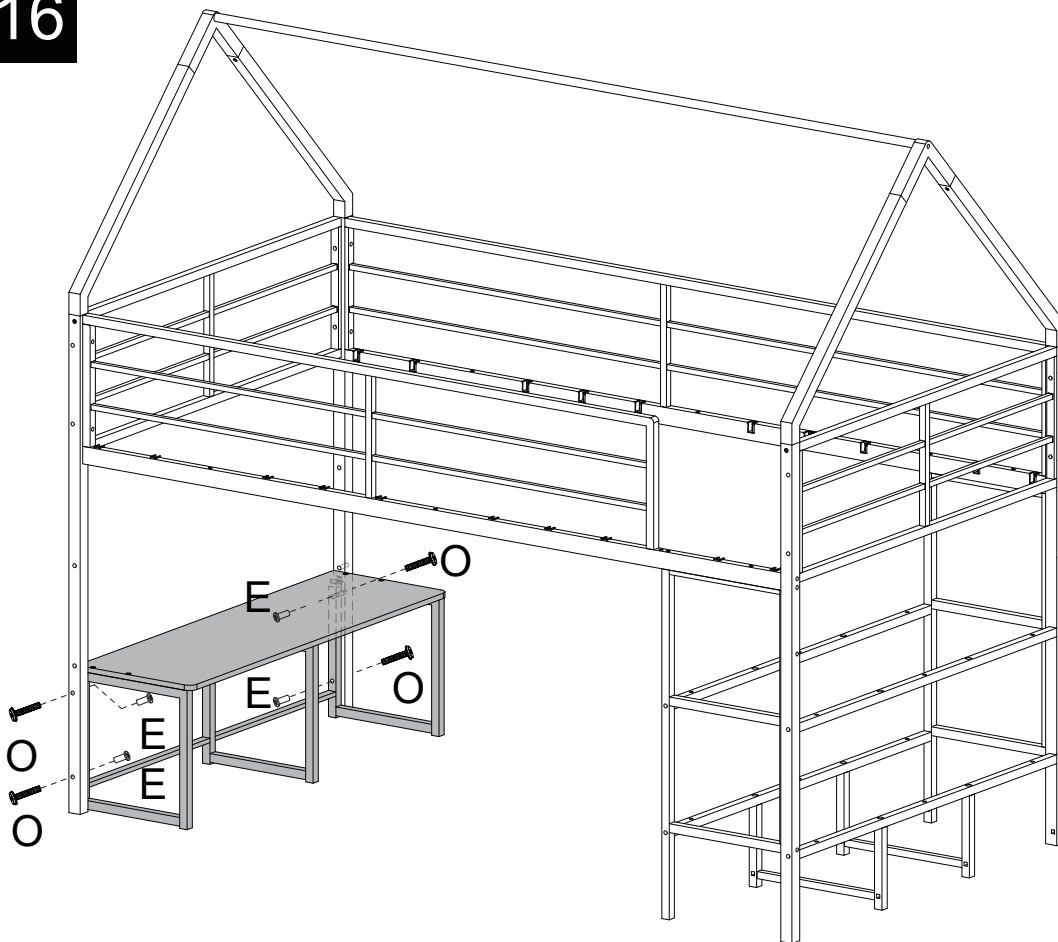

17

Note that when assembling parts (12) and (13), the iron frame is first aligned with the hole and then locked.

- C M6*40 X2
- L M6*28 X2
- U M6*25 X2

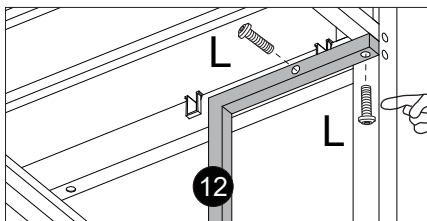

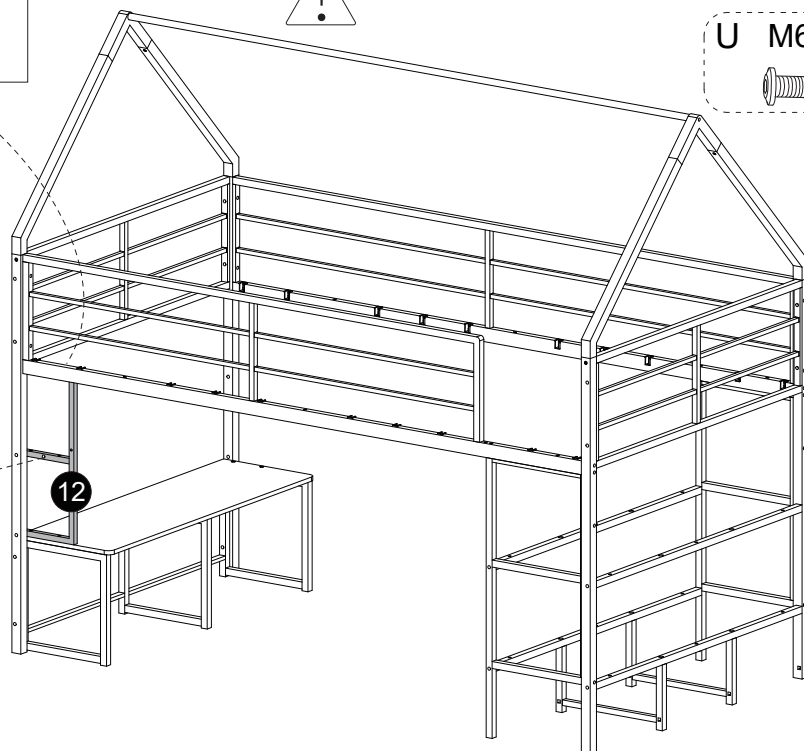
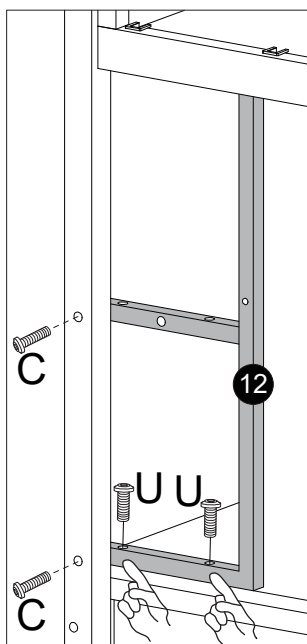

Lock this screw first.



Assembly Instruction

18 Note that when assembling parts (12) and (13), the iron frame is first aligned with the hole and then locked.

- C M6*40  X2
- L M6*28  X2
- U M6*25  X2

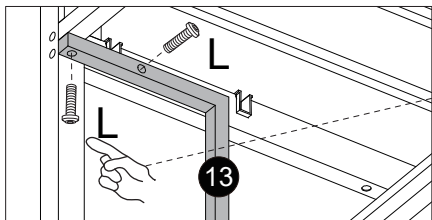

Lock this screw firstked.

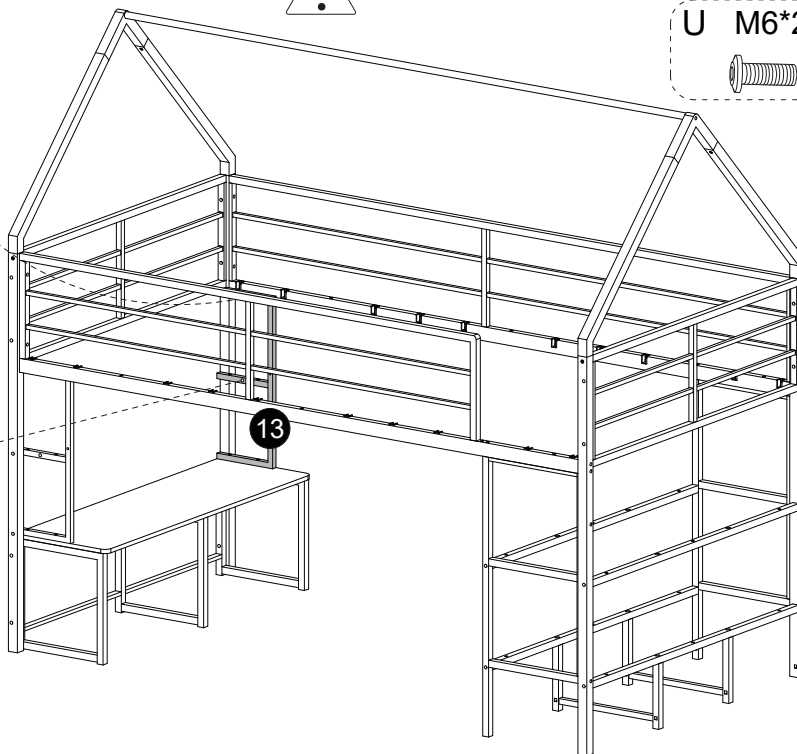
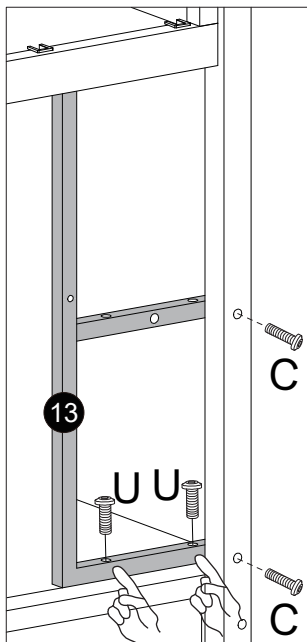

19

- C M6*40  X2

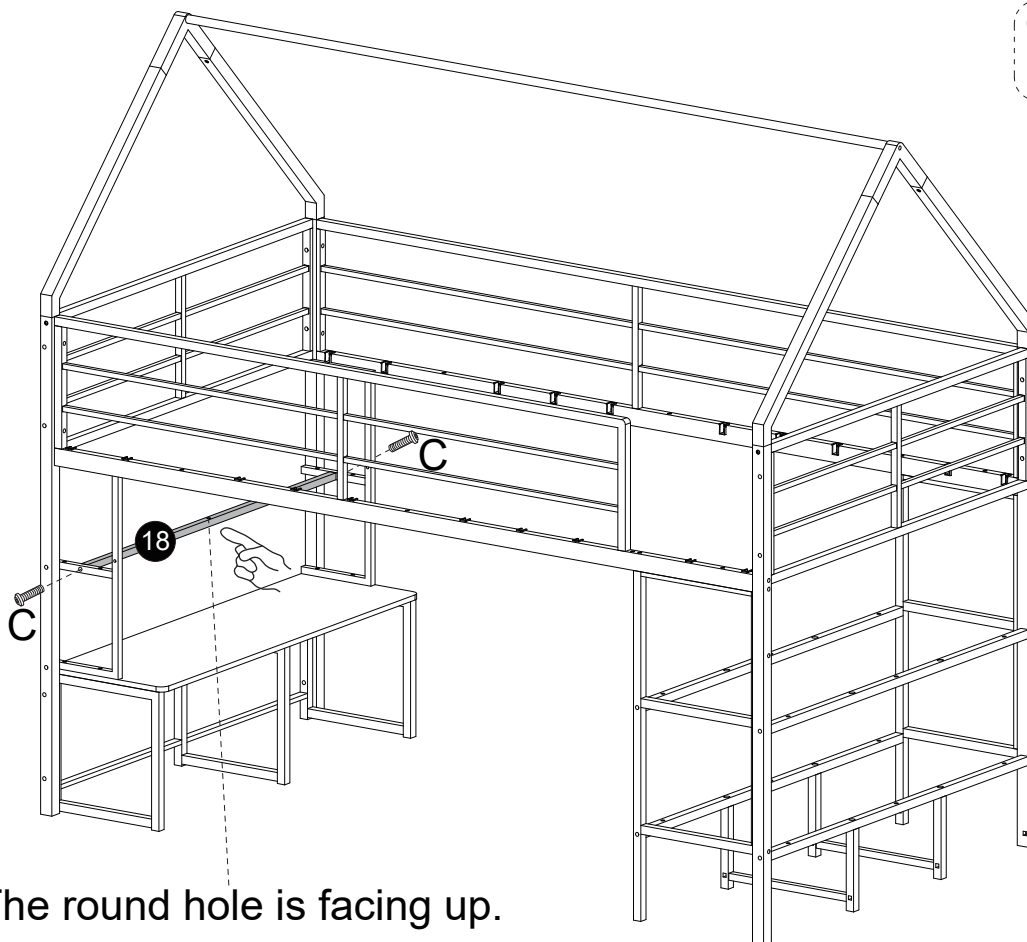

The round hole is facing up.

Assembly Instruction

20



Be careful not to overtighten the screws.

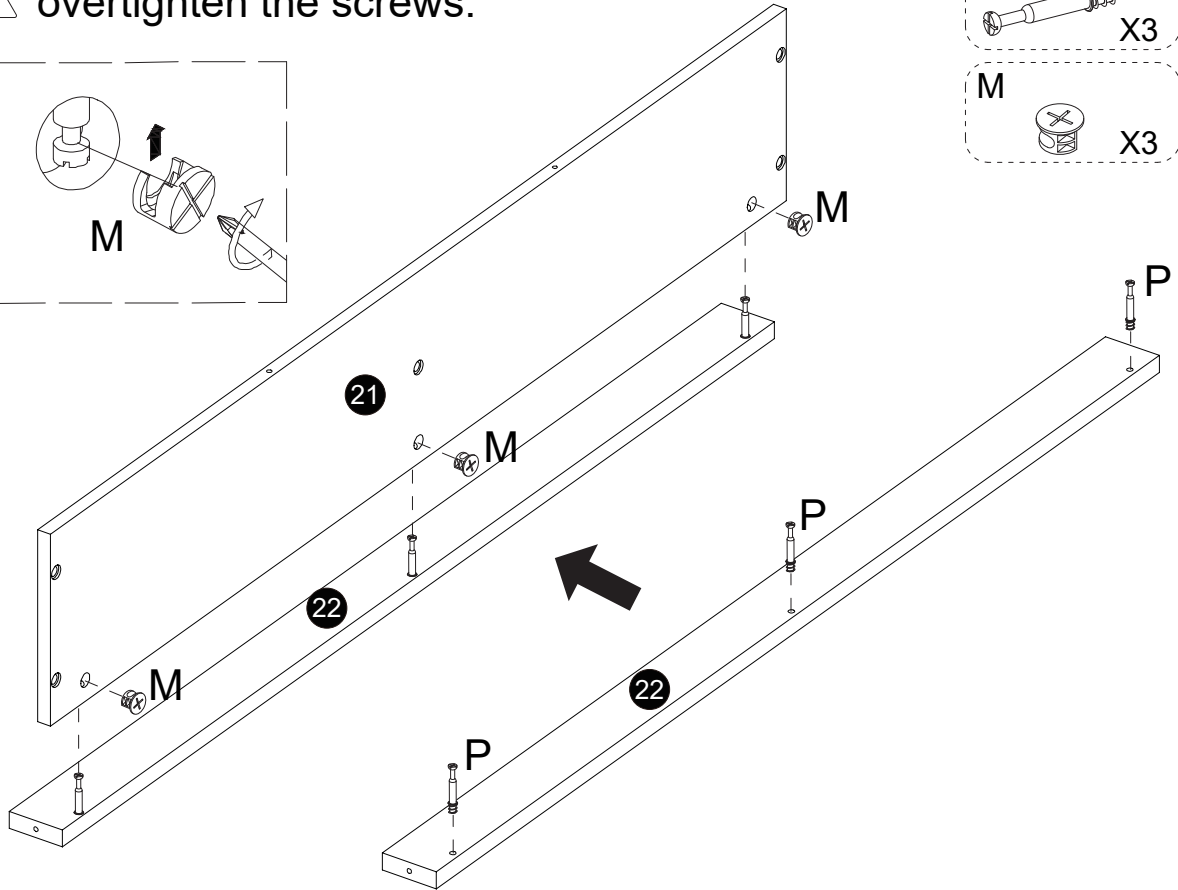
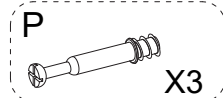
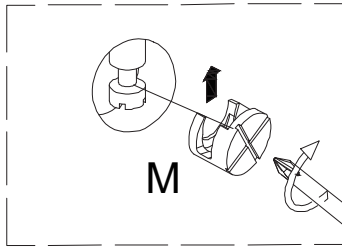

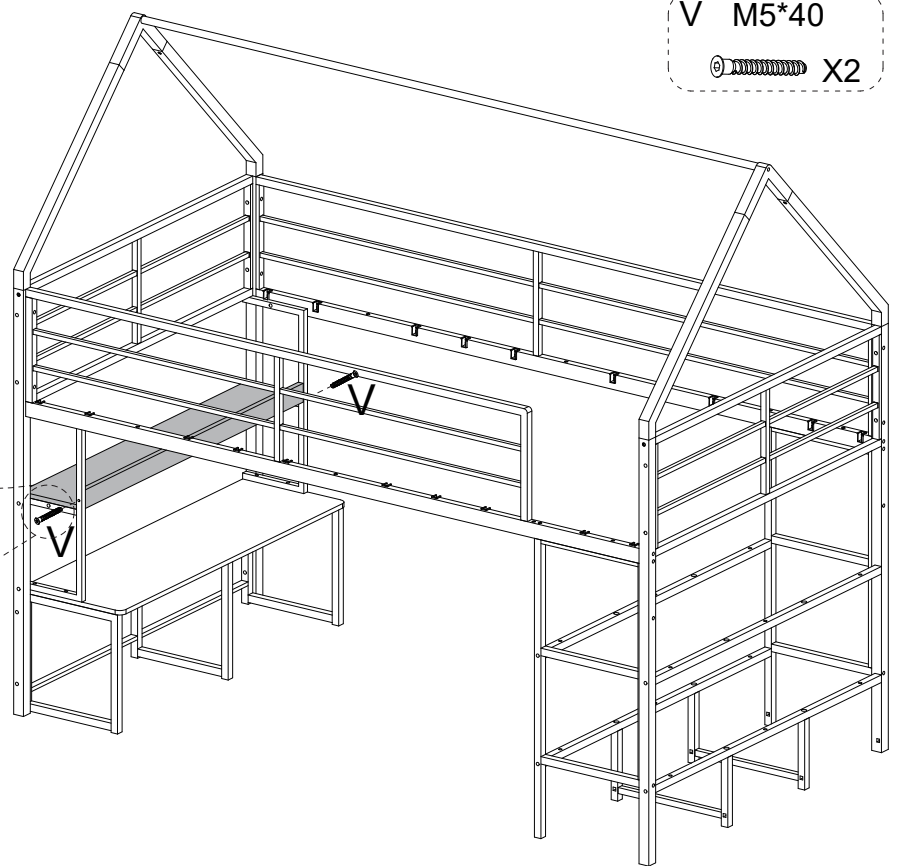
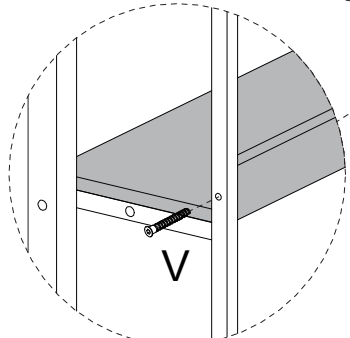
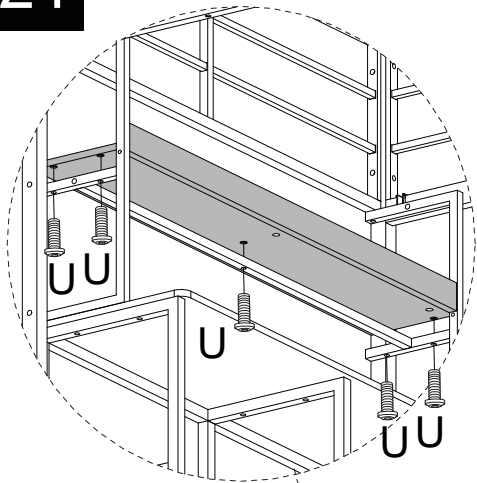
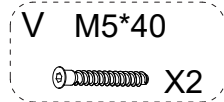

21



Assembly Instruction

22

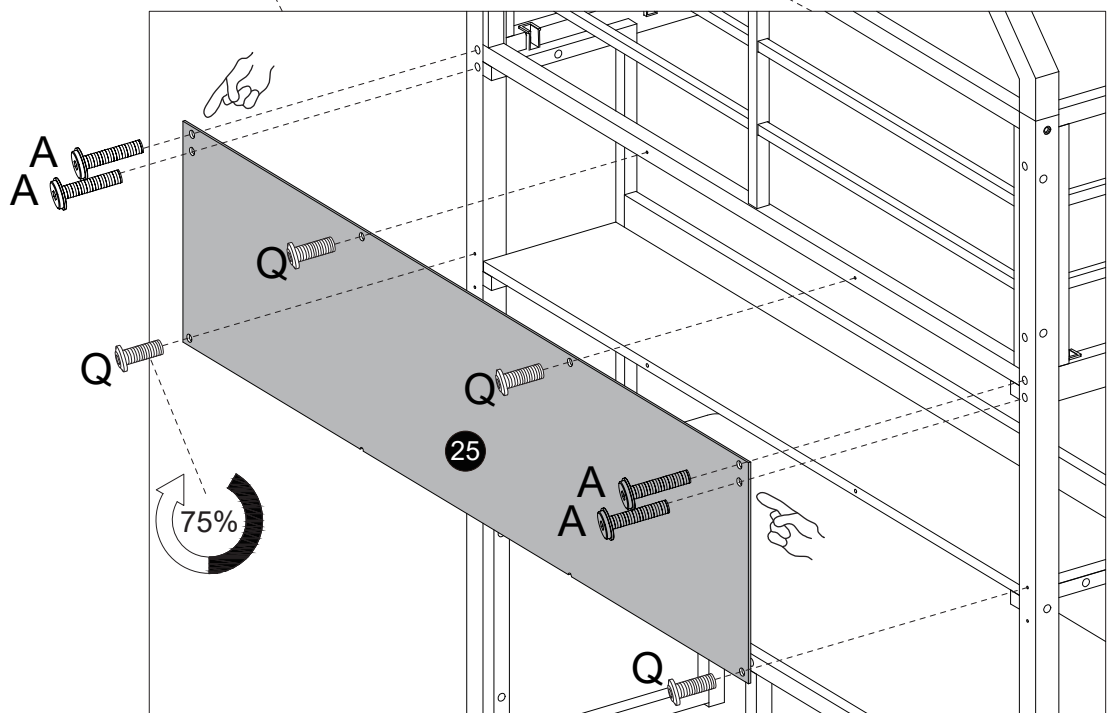
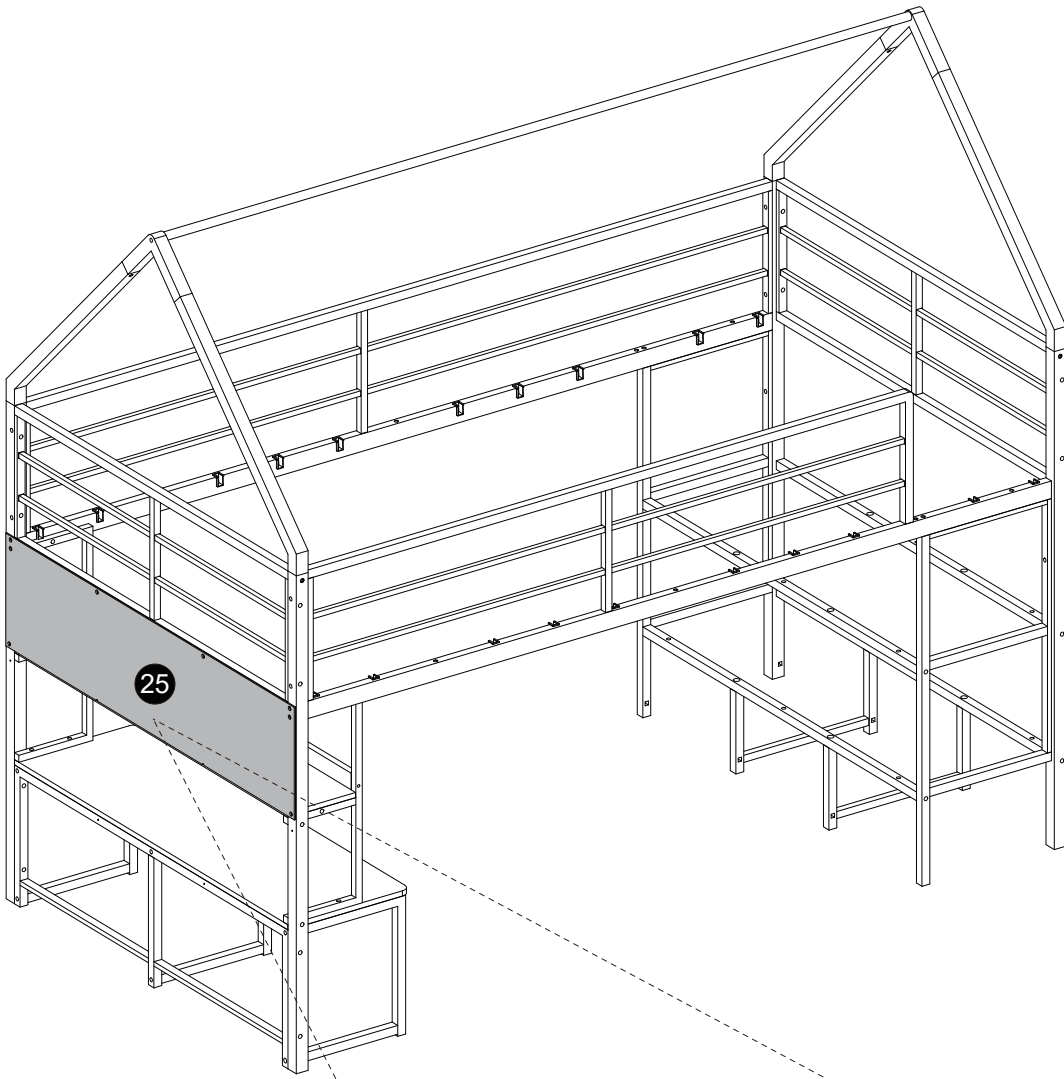

A M8*55
 X4

Q M6*18
 X4



Assembly Instruction

23

- C M6*40
 X3
- Q M6*18
 X4

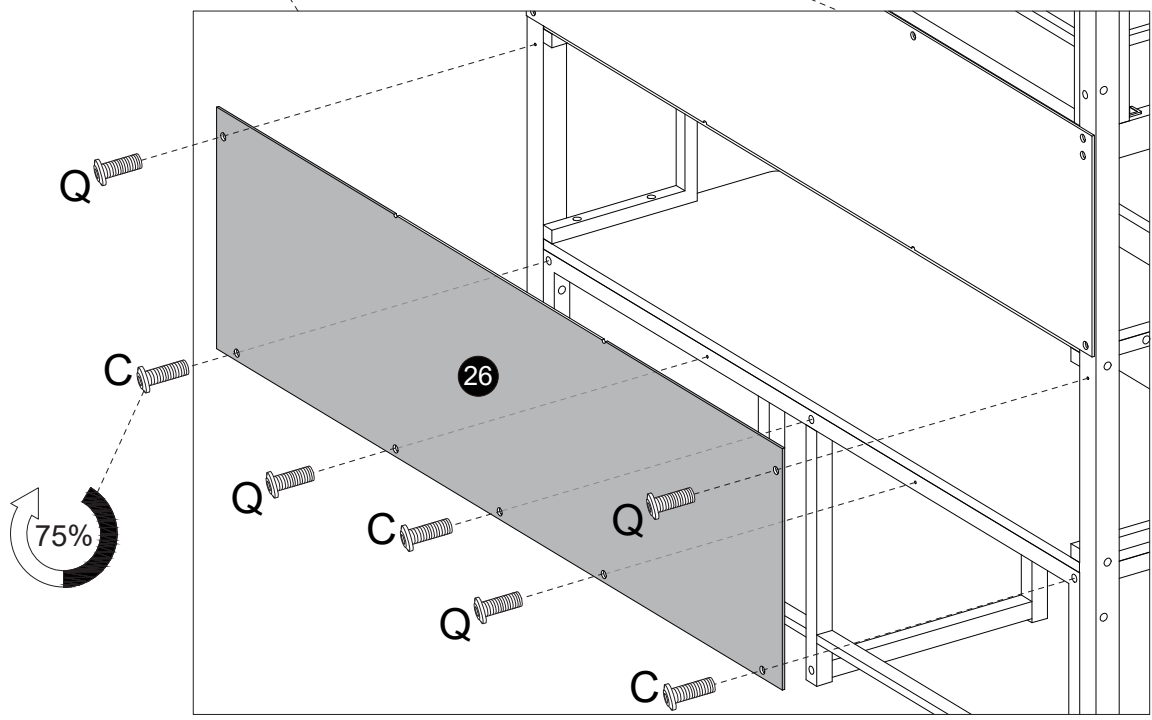
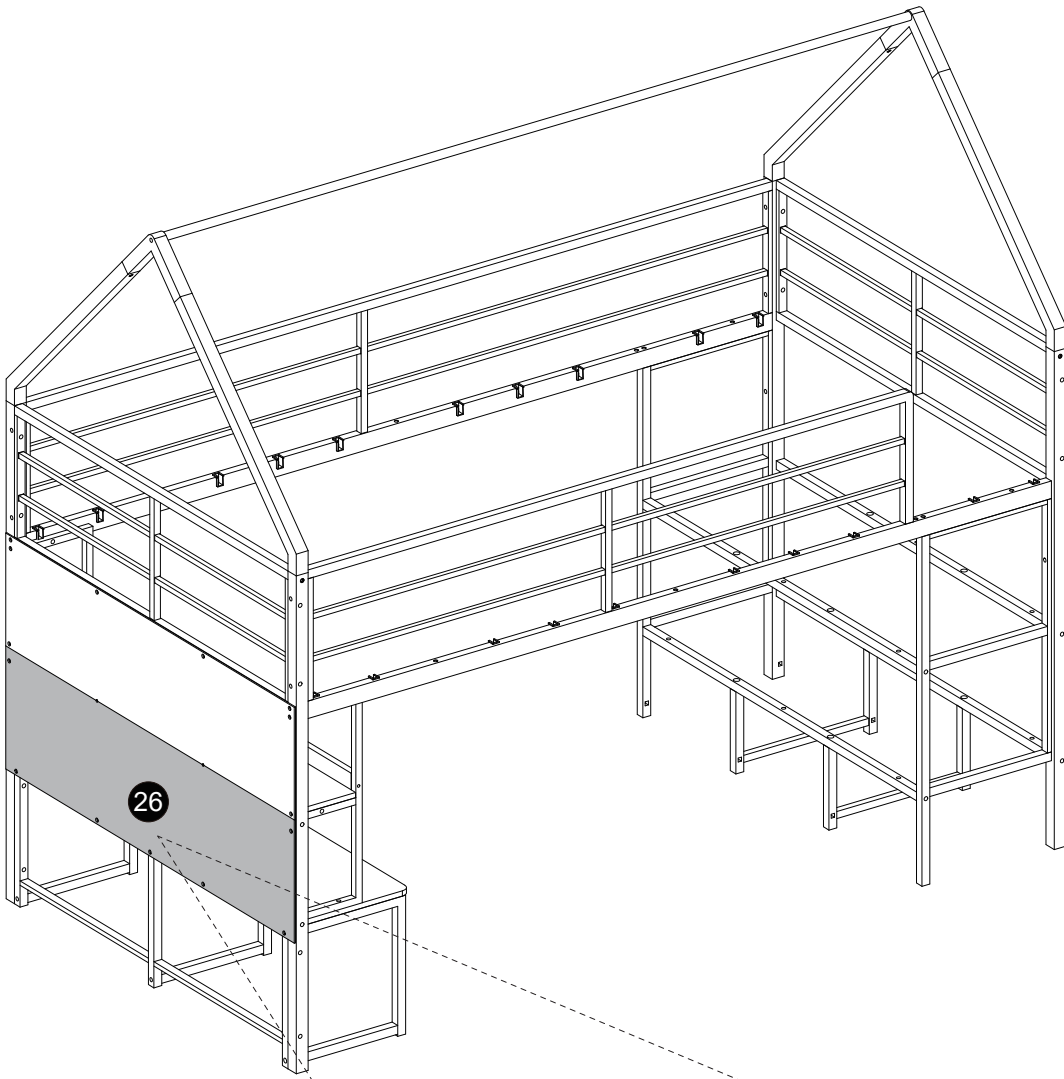

Assembly Instruction

24

V M5*40 X2

A1 X2

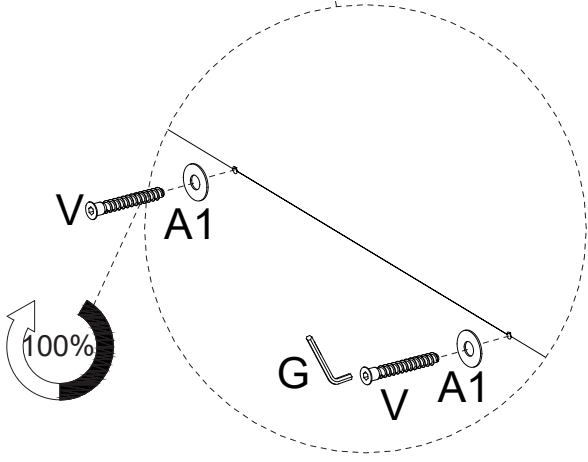
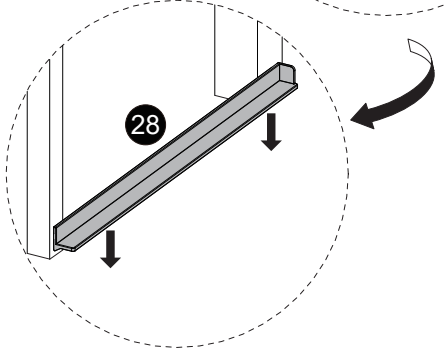
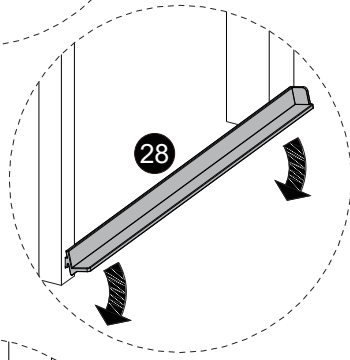
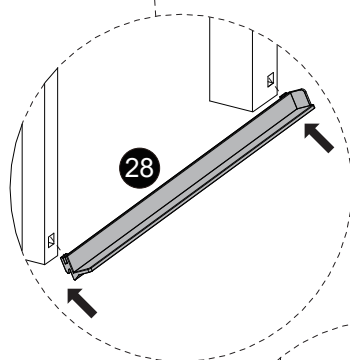
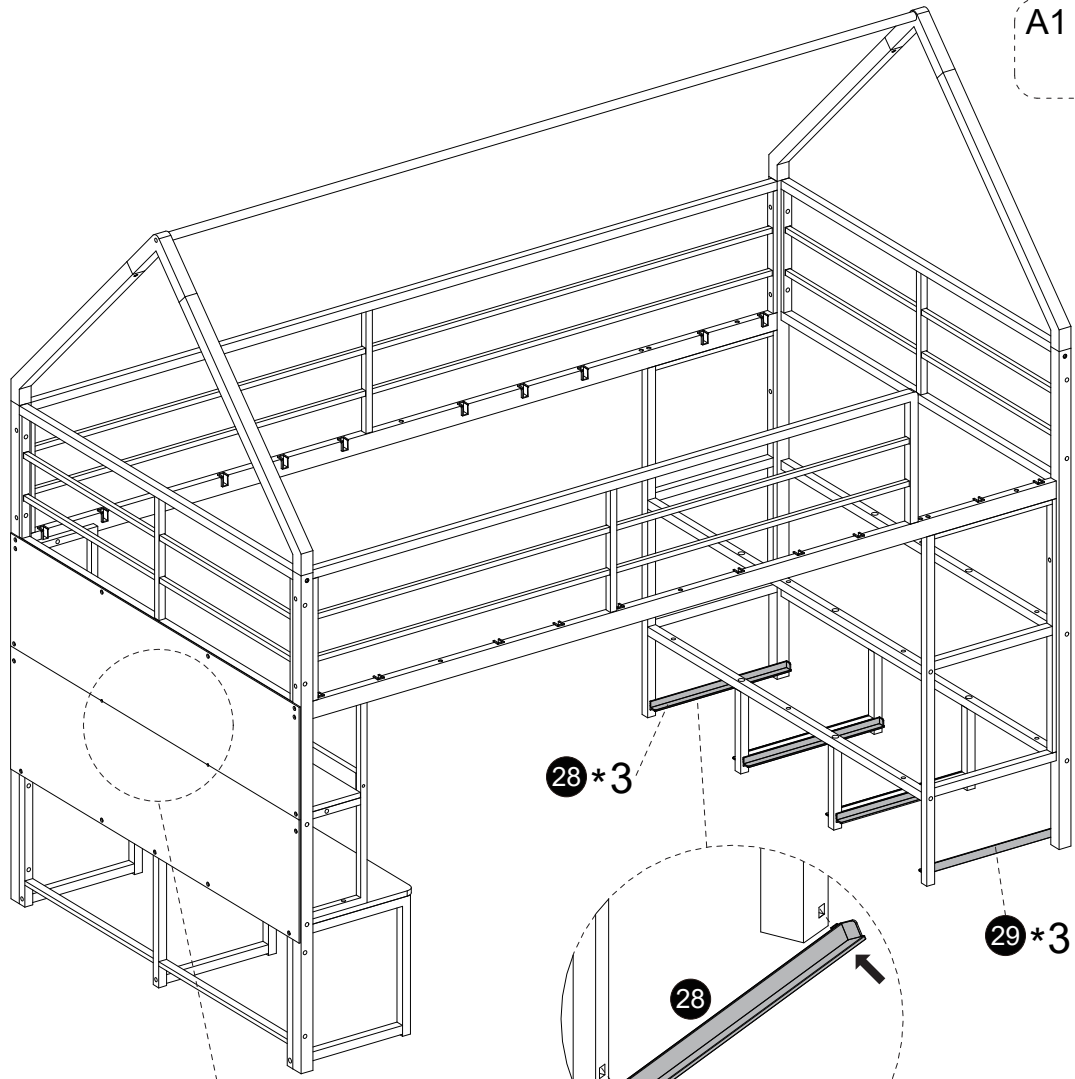

Assembly Instruction

25

L M6*28
X12

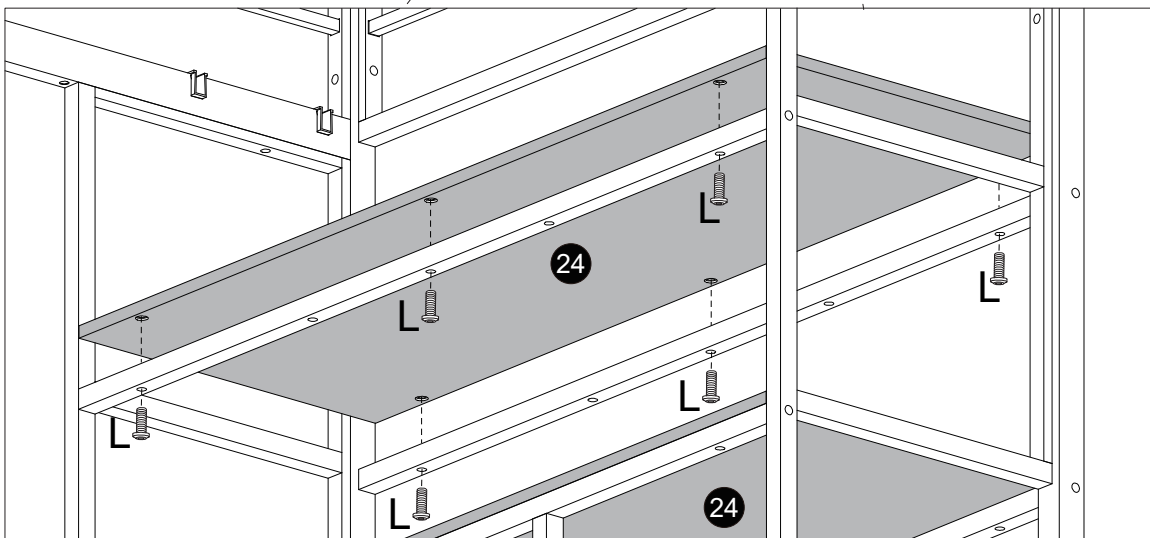
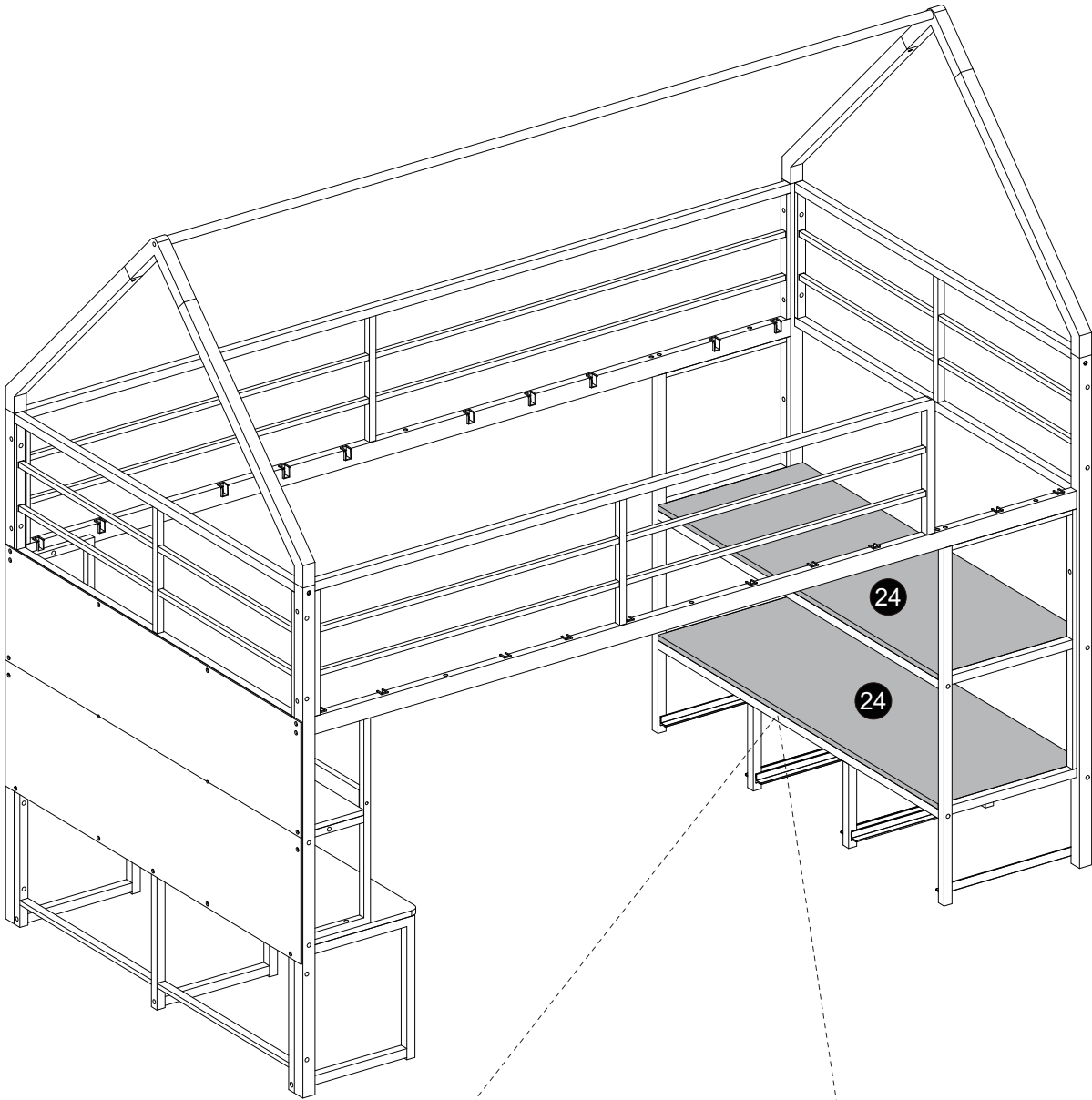

Assembly Instruction

26

- K M4*10 X6
- W X3

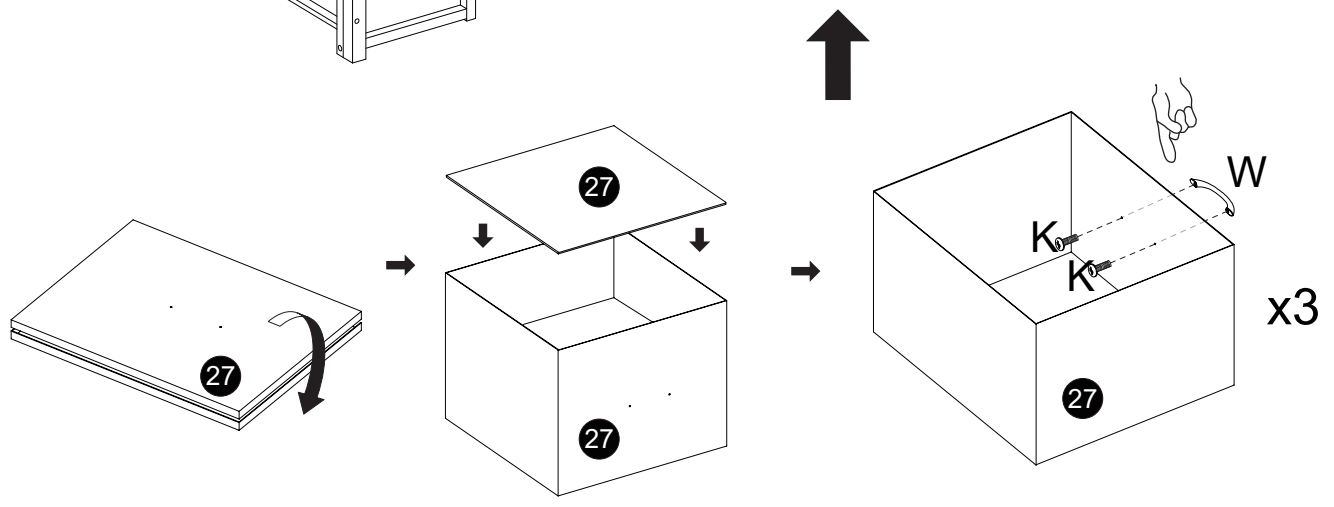
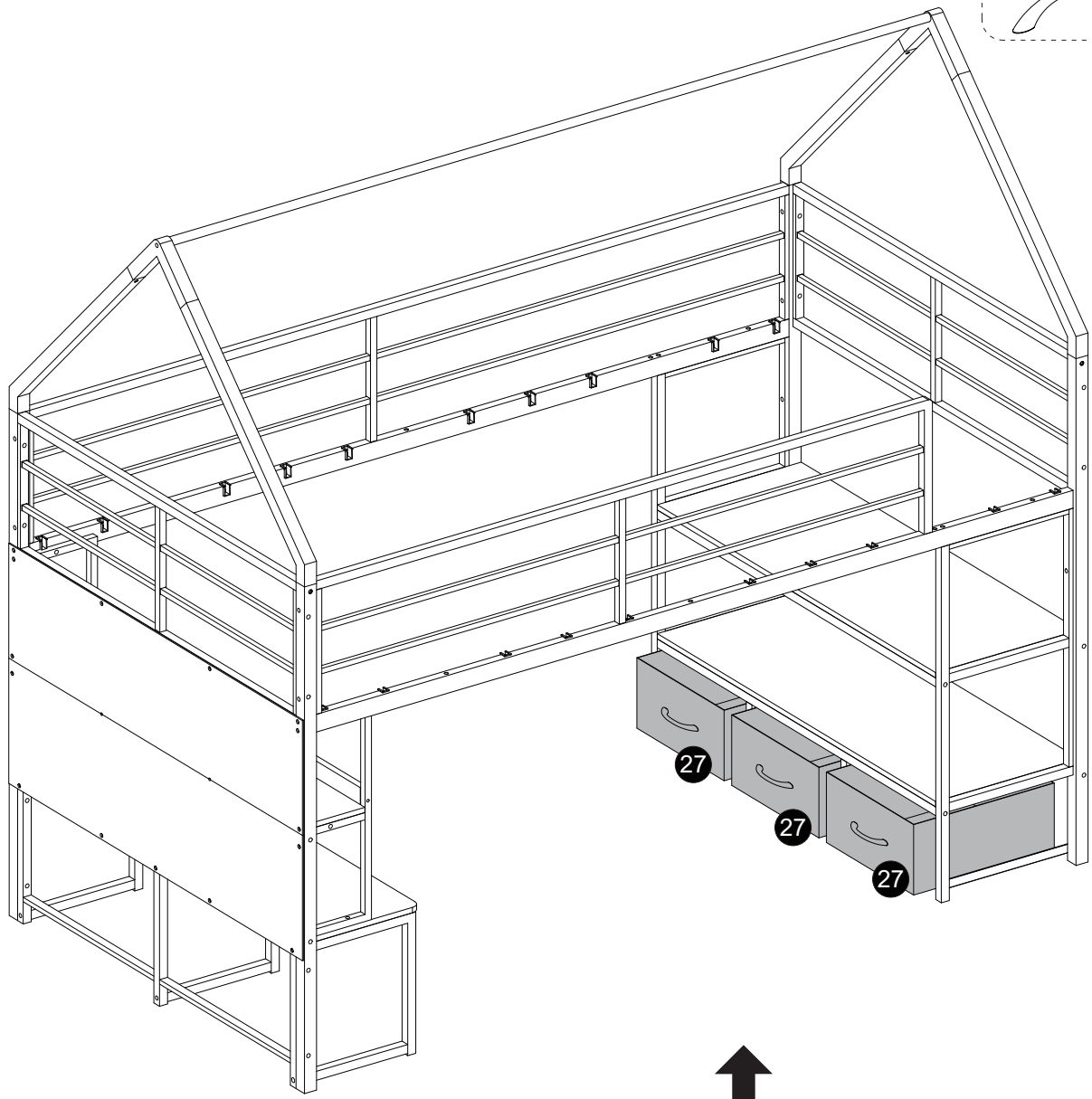

 Be careful not to overtighten the screws.

Assembly Instruction

27

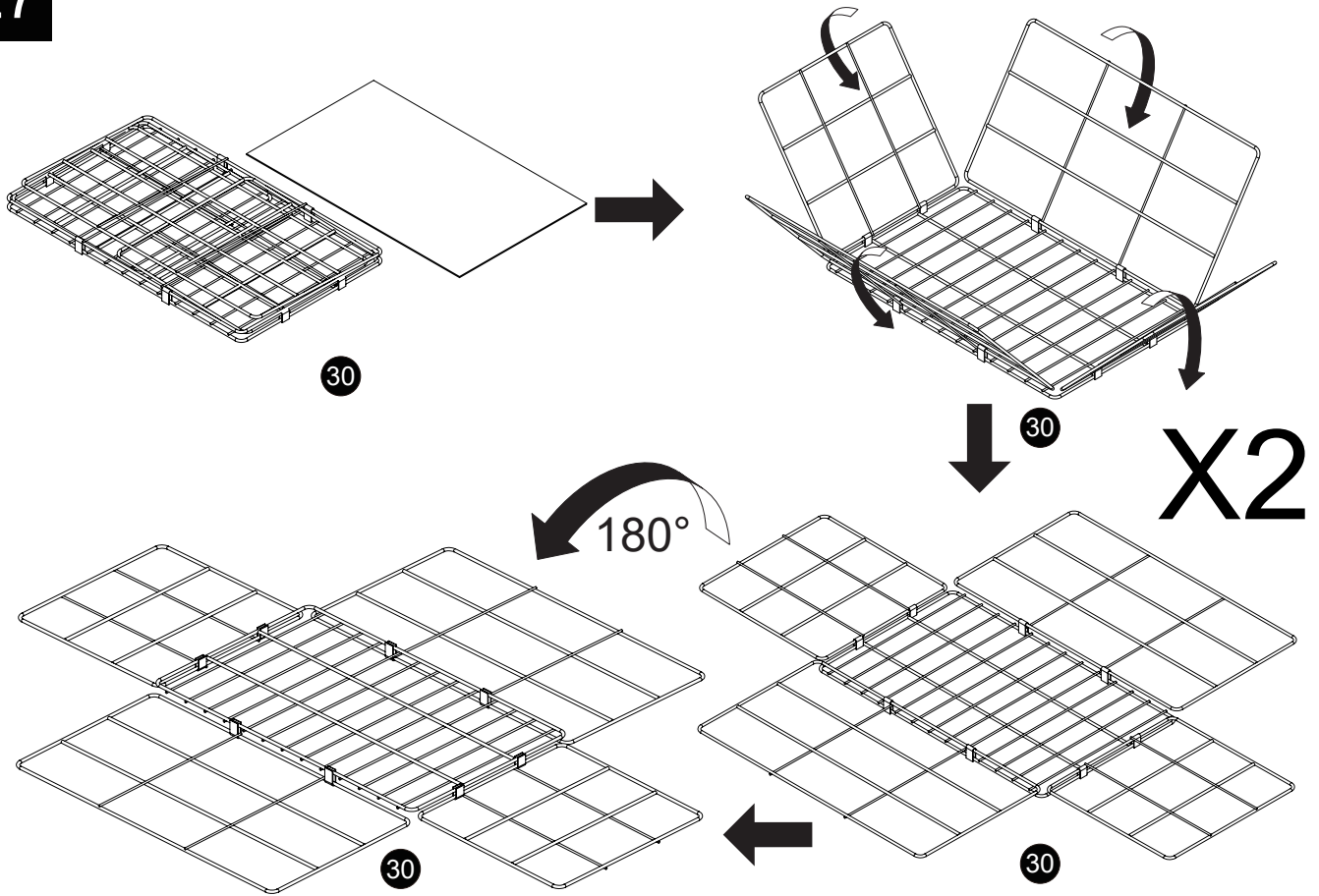

28

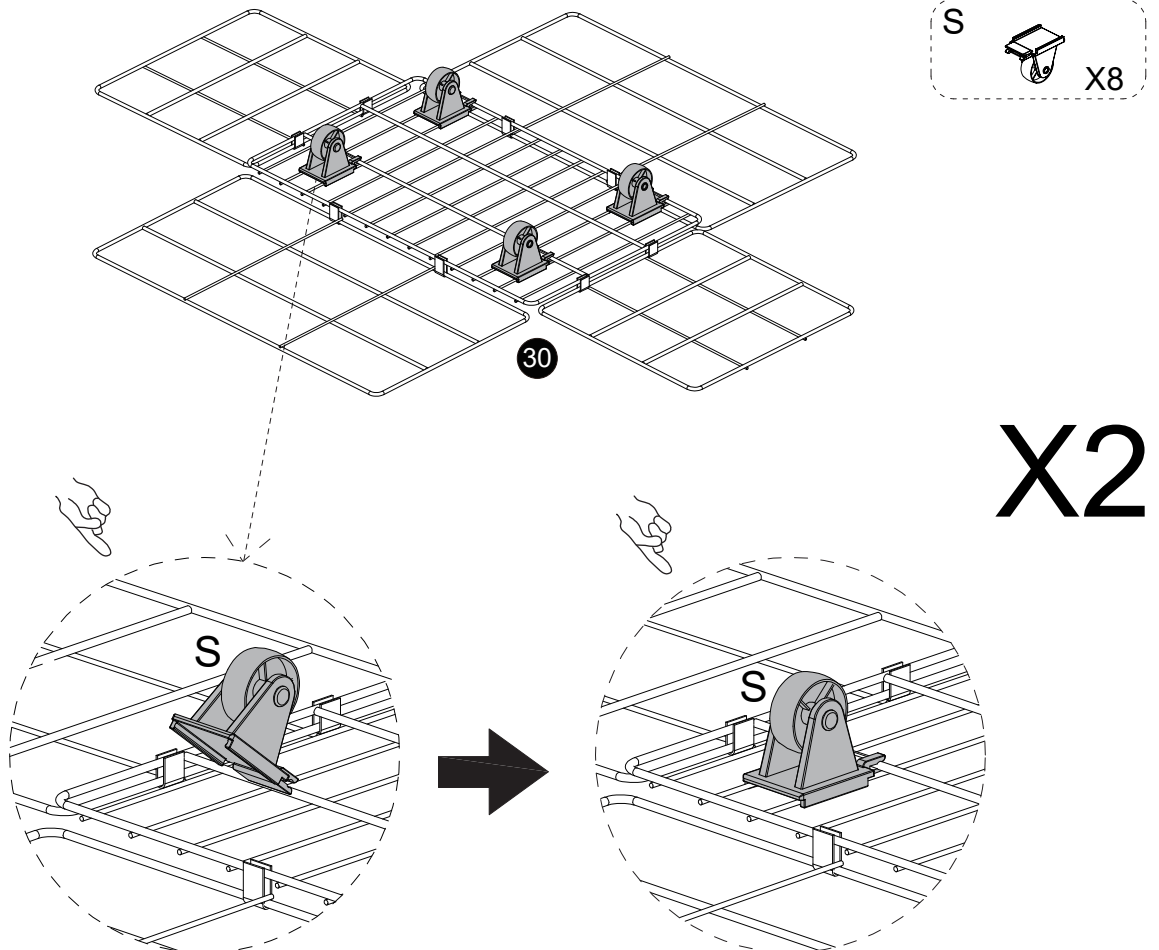

Assembly Instruction

29

J M4*10
 X8

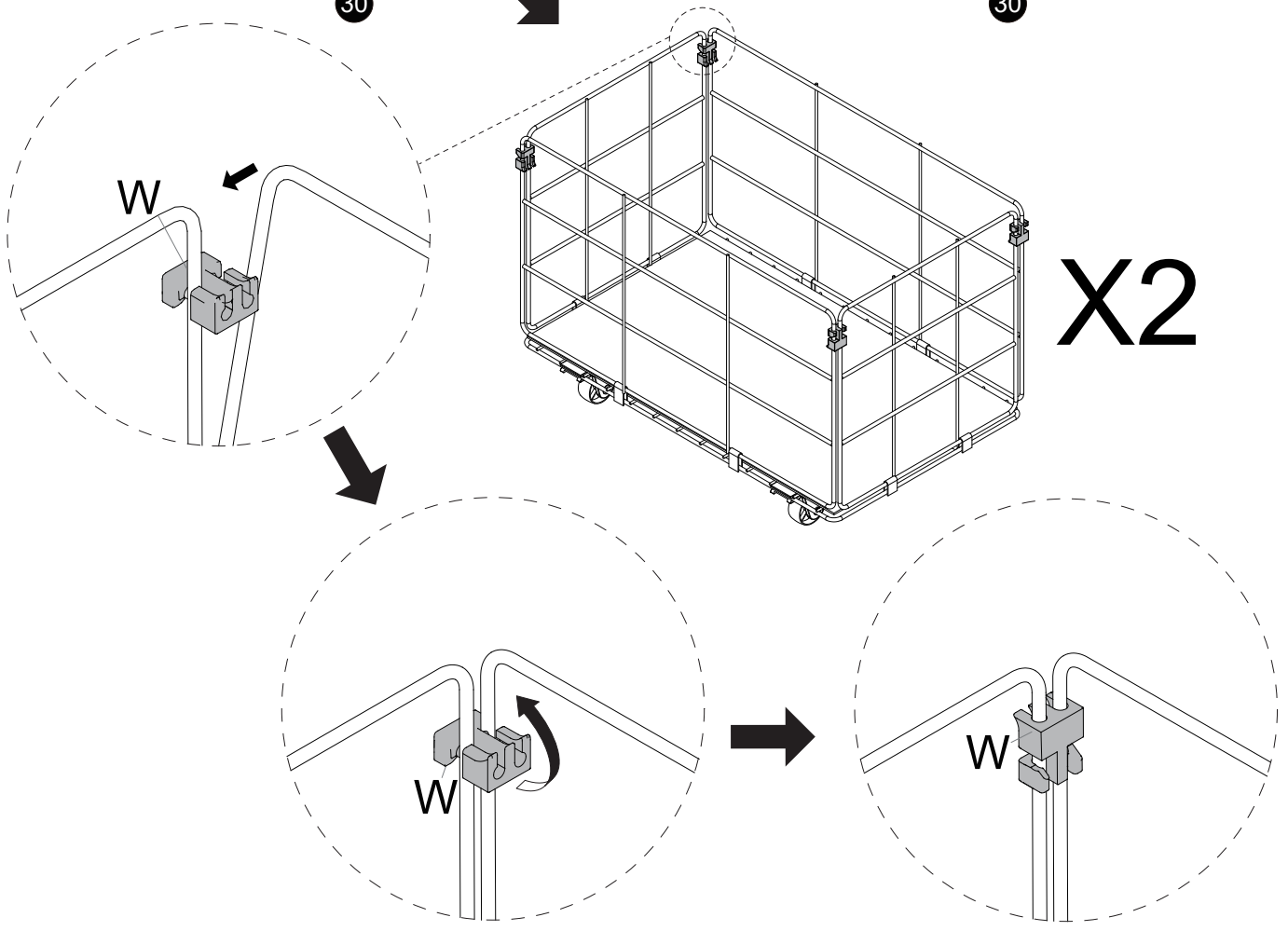
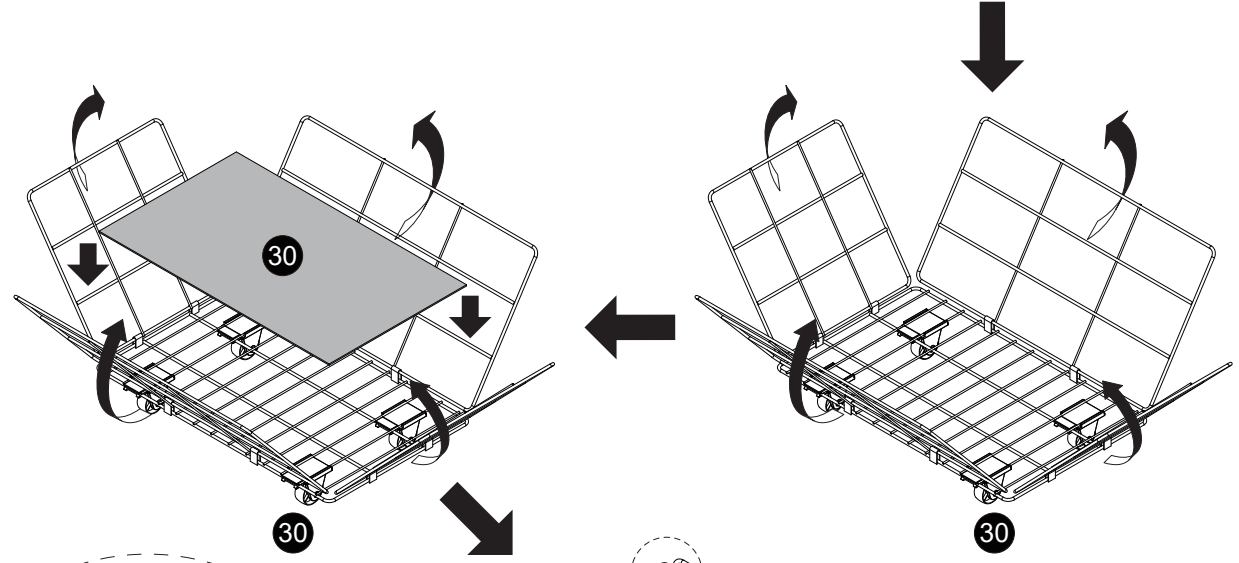
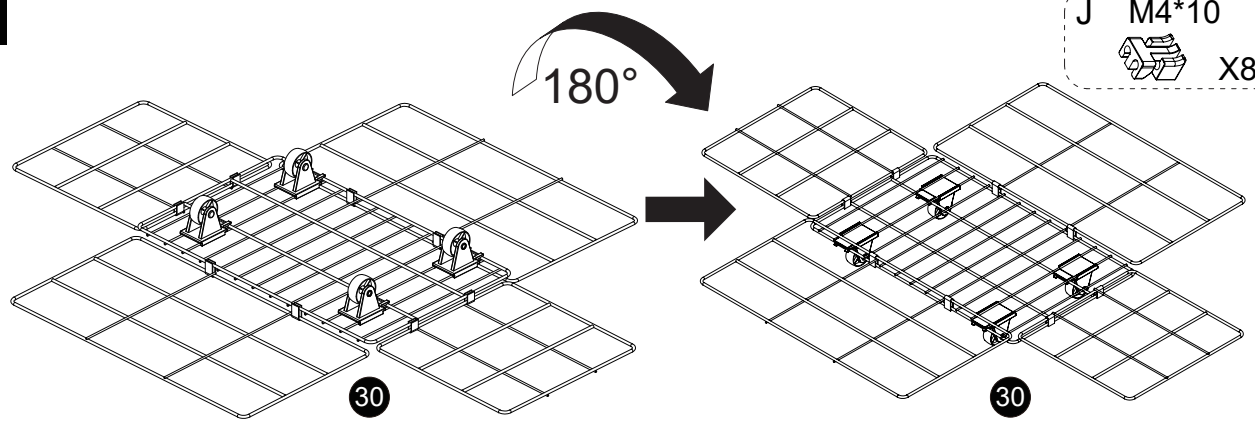

Assembly Instruction

30

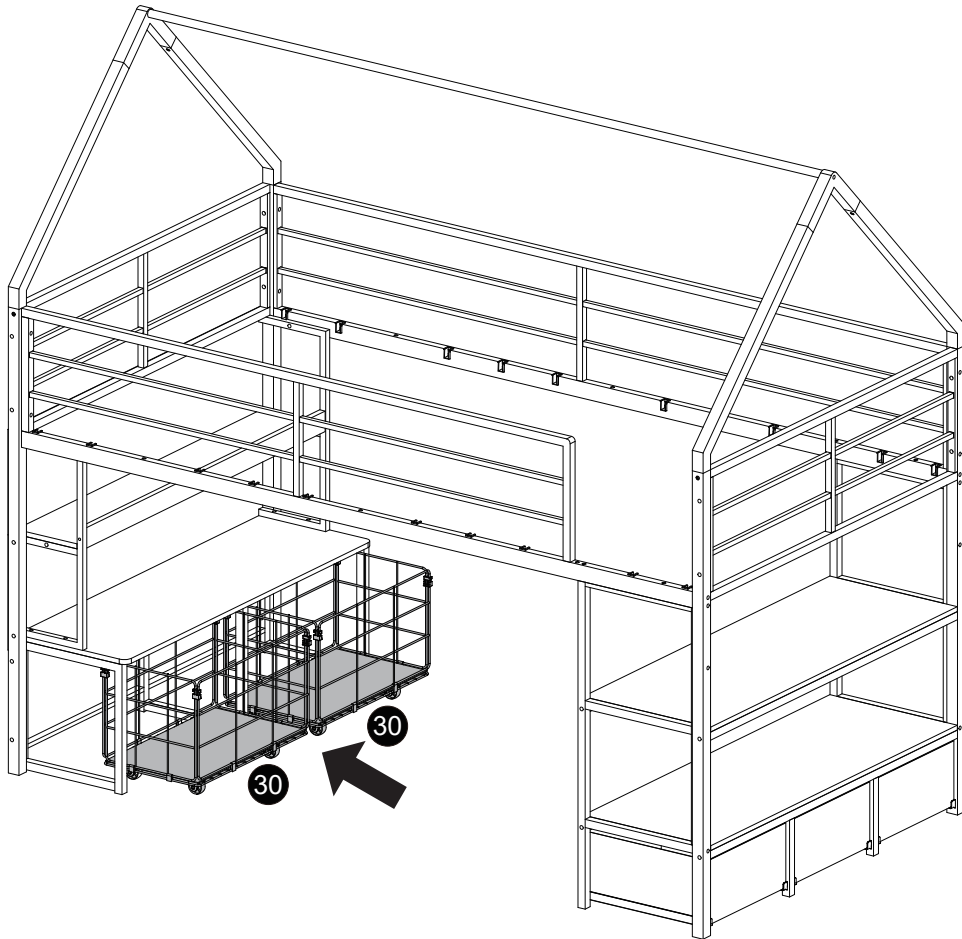

31

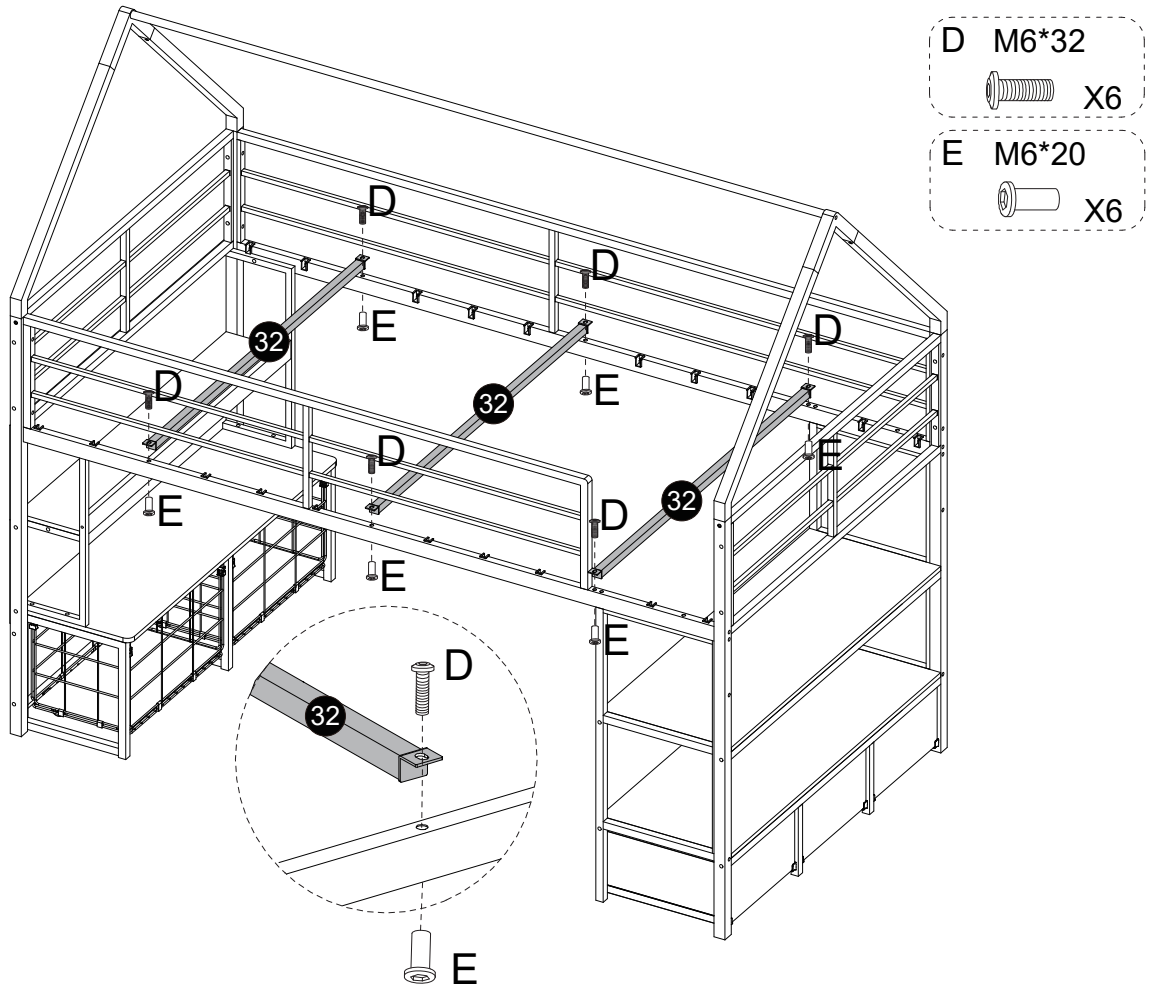

Assembly Instruction

34

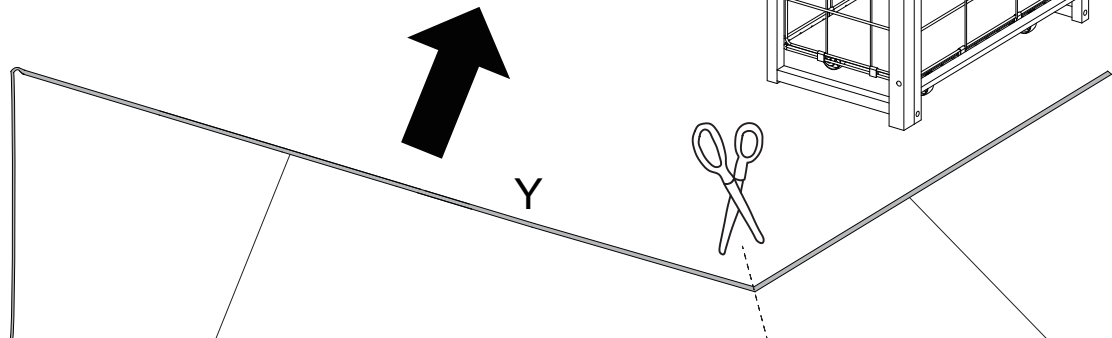
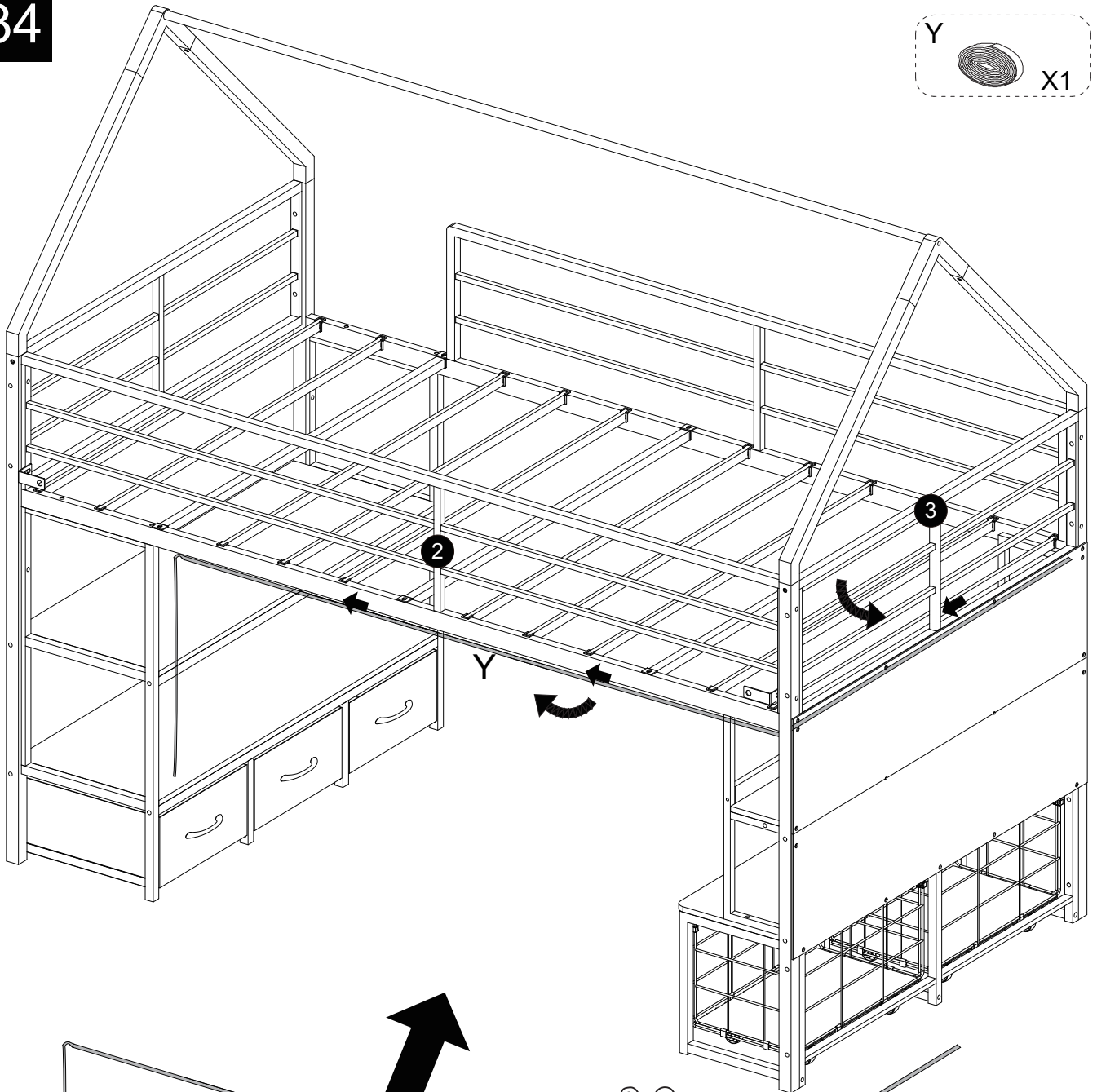

! Stick this part of the Velcro onto the bottom surface of component 2.

! Stick this part of the Velcro onto the bottom surface of inner component 3.

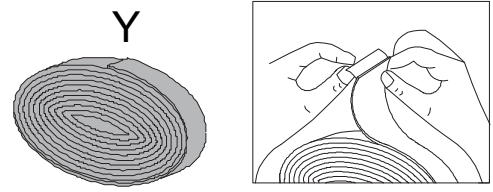

Assembly Instruction

35

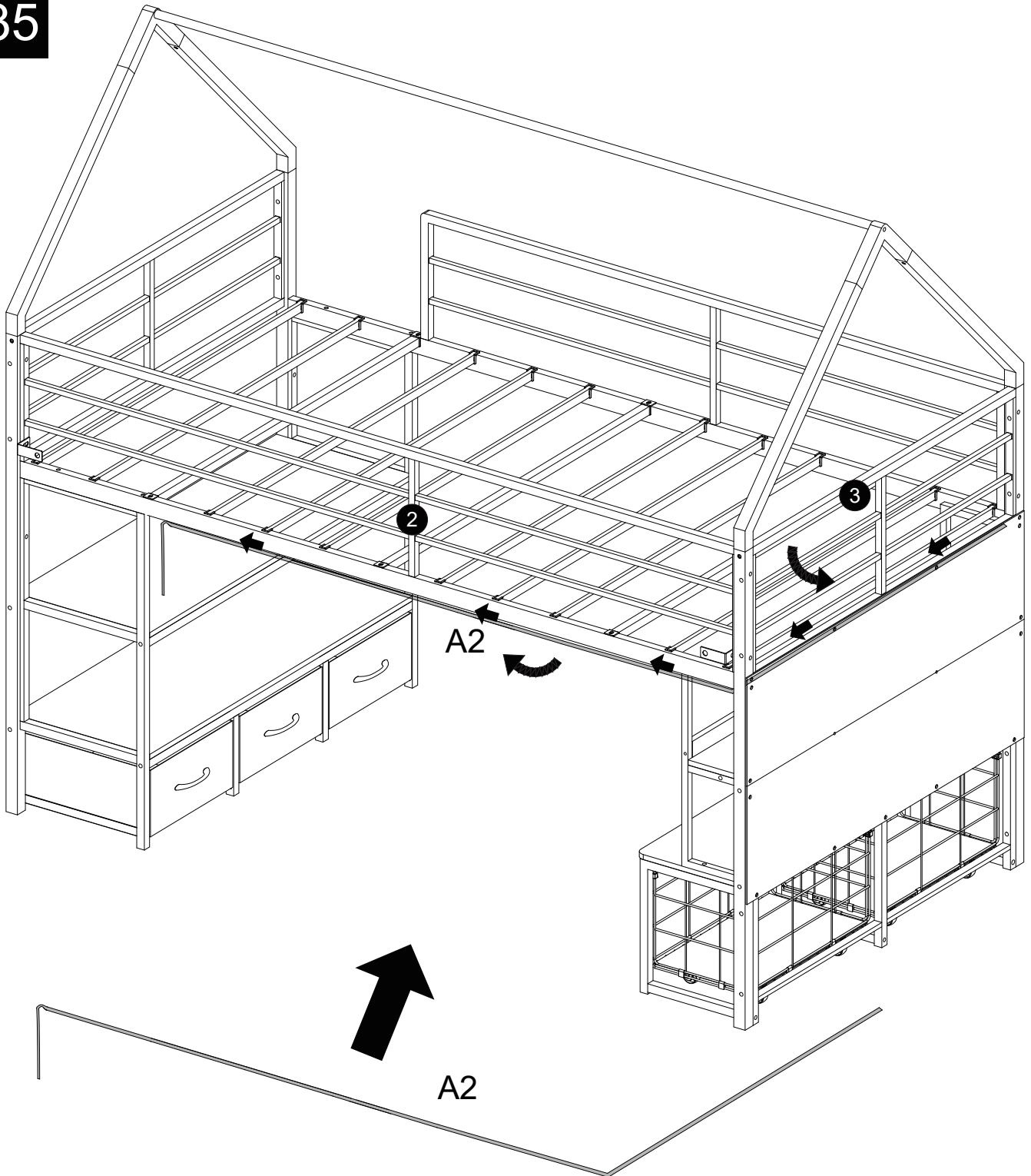

Stick component (A2) onto the two Velcro strips from the previous step.

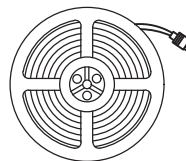

A2 light strip
1PC

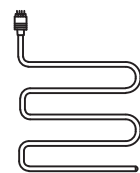
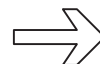

light strip

Assembly Instruction

36

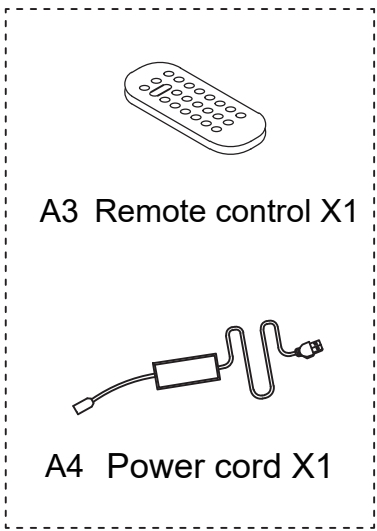

Please loosen the tie and tie it onto the iron pipe. As shown in the figure.

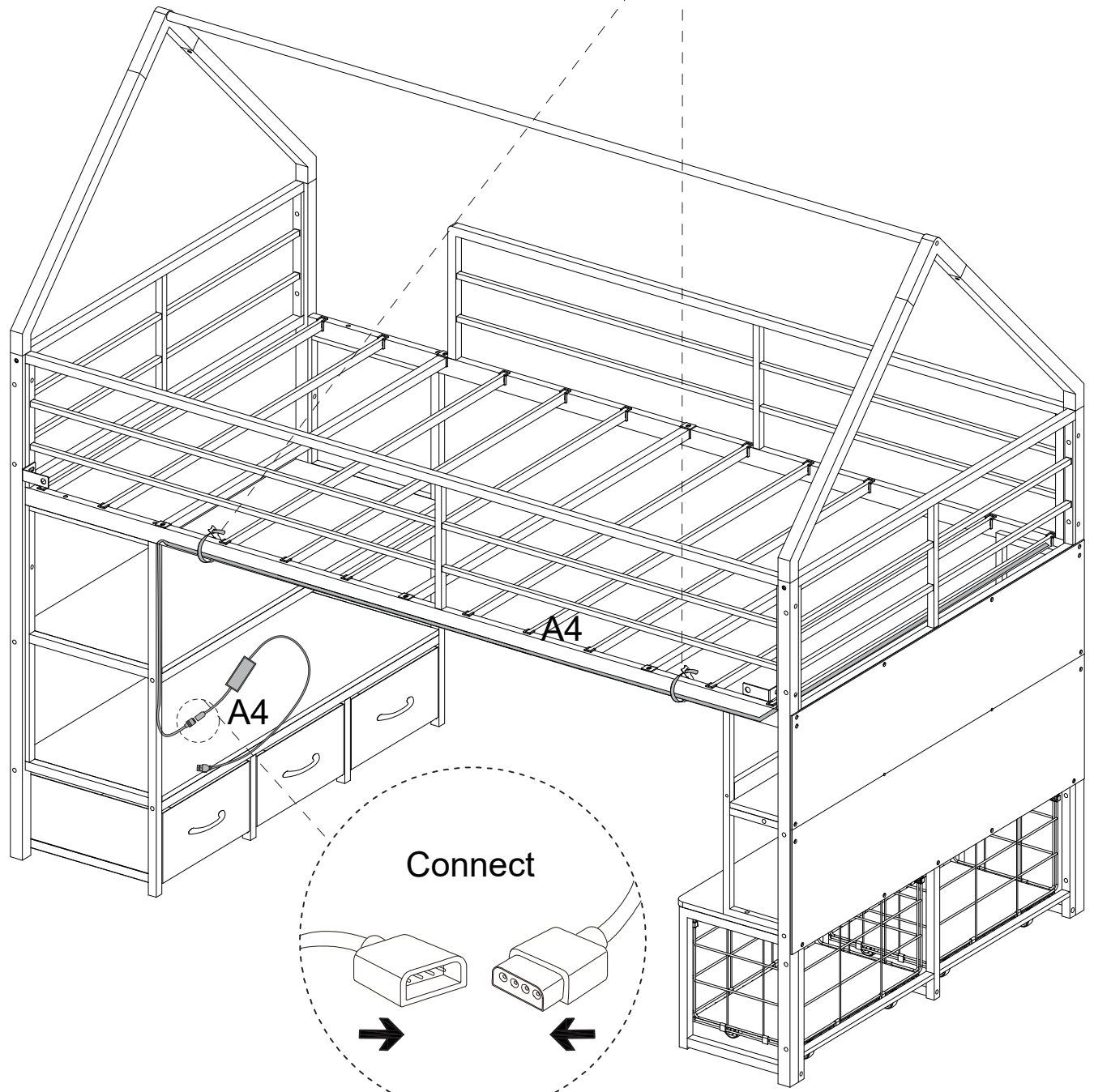
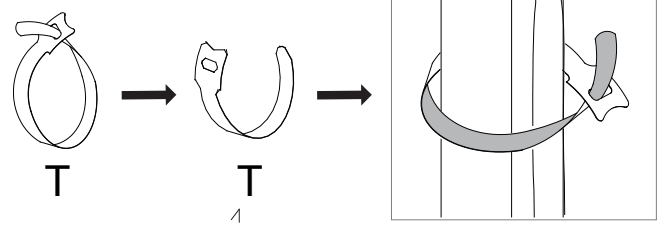

Assembly Instruction

37

T X1

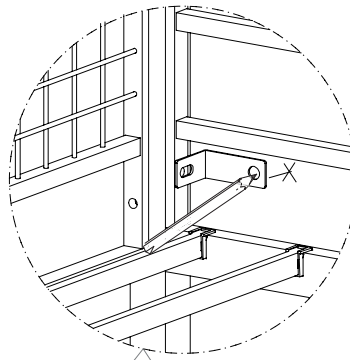

wall

wall

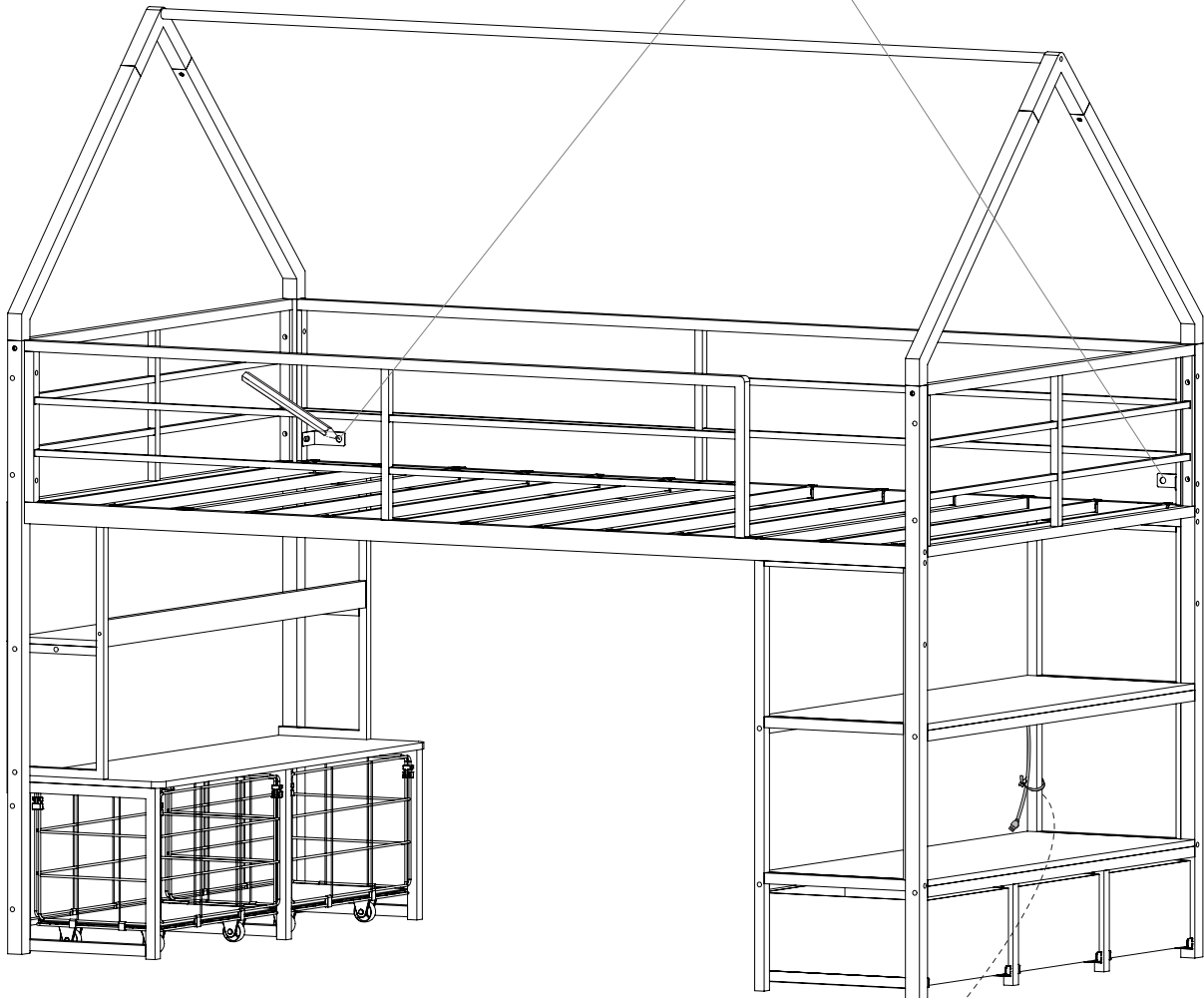

Please loosen the tie and tie it onto the iron pipe. As shown in the figure.

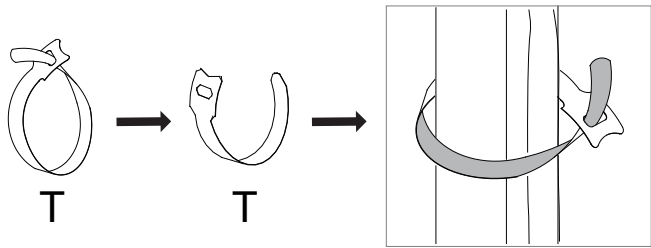

Assembly Instruction

38

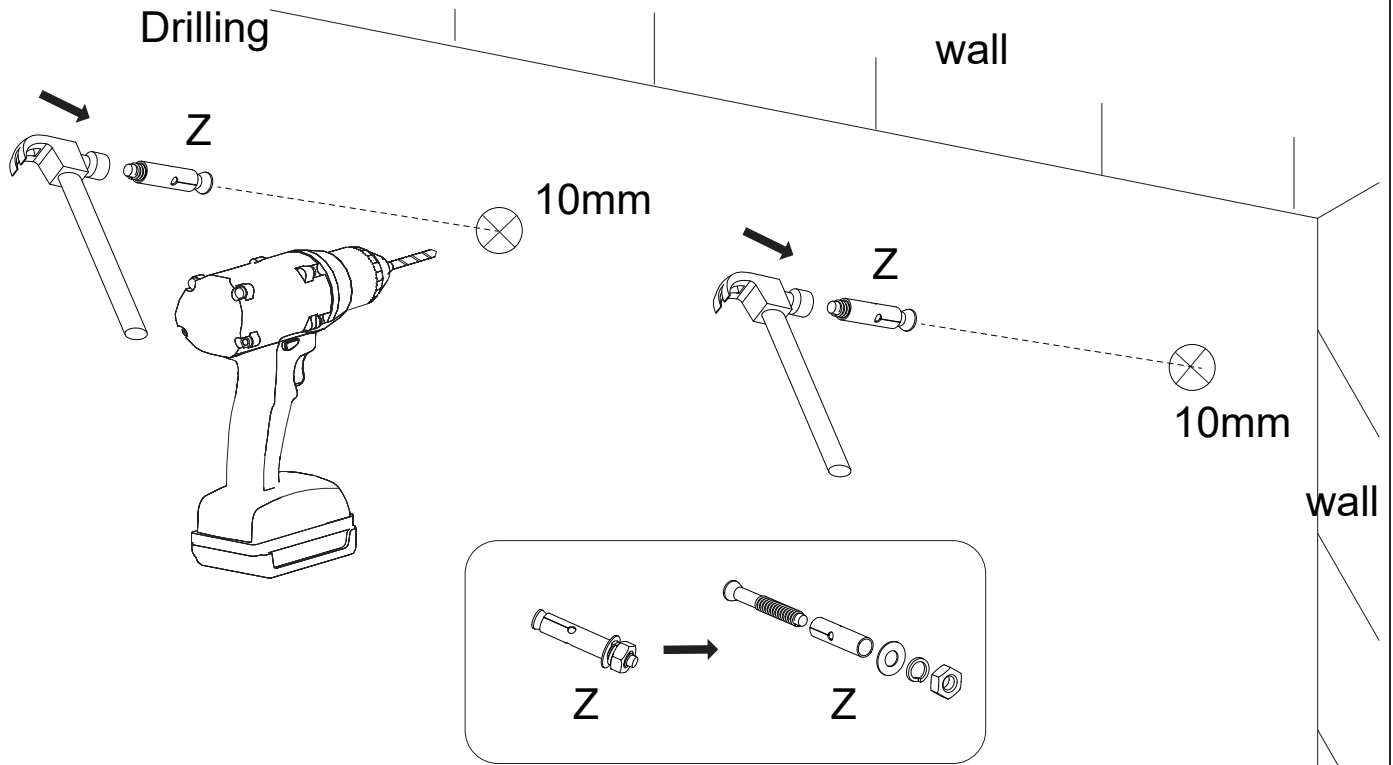

Please lock the expansion screw onto the wall.

39

