

ASSEMBLY INSTRUCTIONS

Bench

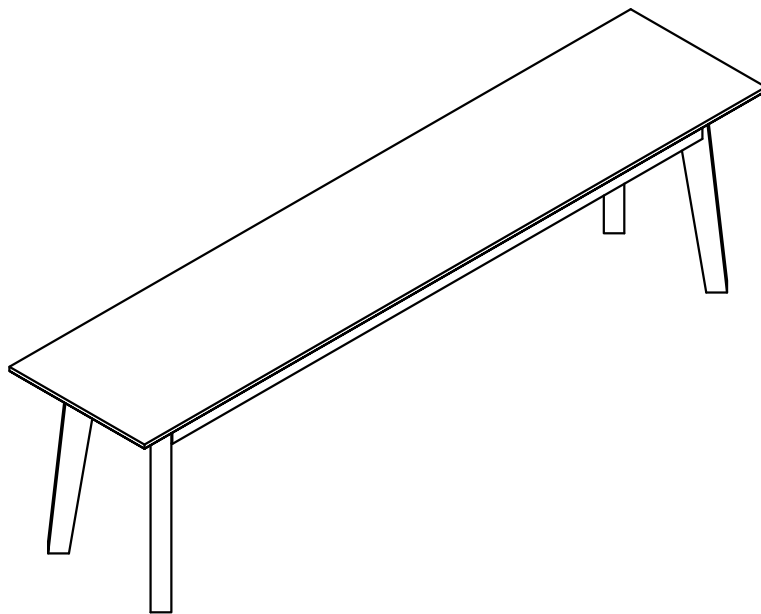

- Unpack all hardware bags and components to ensure you have all parts -



- Read instructions, cover to cover -



- Have 2 adults on hand for assembly -



- Do not assemble on flooring or carpet -



- Assemble on a clean non-marking surface (packing foam) -



- Save all packaging until finished -

ASSEMBLY INSTRUCTIONS

A. (M10x70) x8



B. (Ø10/Ø22mm)x8



C. (17mm) x1



① x1

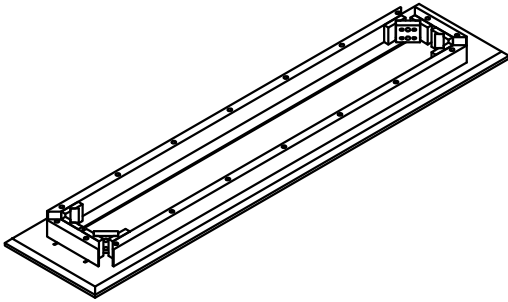

② x4



STEP 1



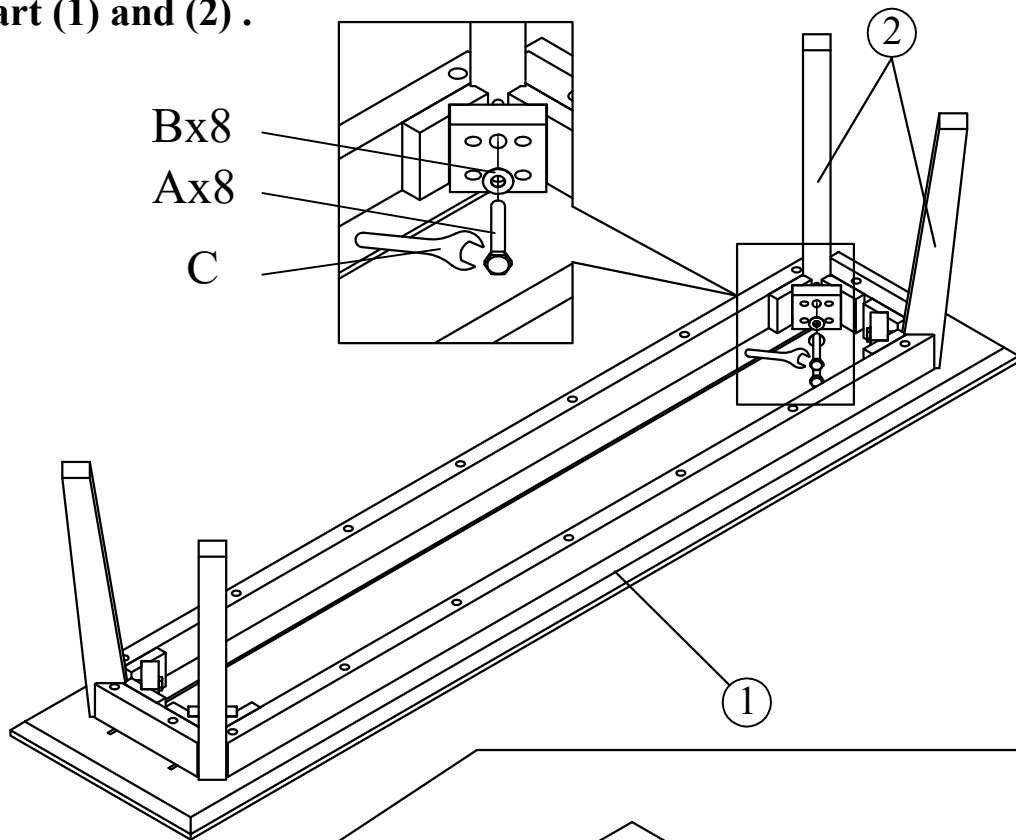

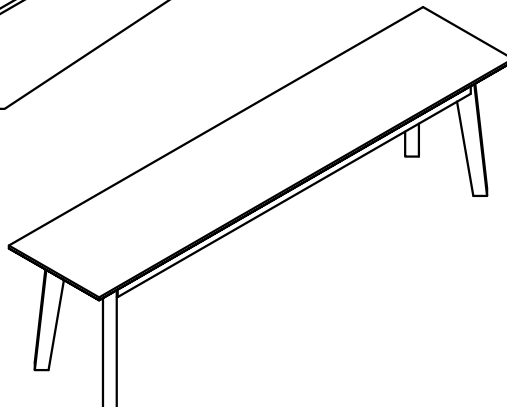

Assemble part (1) and (2).



Assembly is complete.



CARE & MAINTENANCE

-  Do not put hot items directly on furniture surface.
 -  Do not clean furniture with harsh cleansers or polish.
 -  Do not place furniture near heating or cooling vents.
 -  Do not write on furniture without a padded barrier to protect the surface.
 -  Not for commercial use. For residential use only.
 -  Stains may be removed with mild soap solution and damp cloth.
 -  Indoor / outdoor use
(Rust resistant / -15 degrees Celsius / - 59 degrees Fahrenheit)
-

-  Dust and pick-up spills using a clean, non-colored, lint-free cloth.