

ASSEMBLY INSTRUCTIONS

Item No : WF299164AAK

Description : DRESSER

Thank you for purchasing this quality product. Be sure to check all packing material carefully for small part that may have come loose inside carton during shipment.



WF299164AAK

ASSEMBLY INSTRUCTIONS

Item No : WF299164AAK

Description : DRESSER

Thank you for purchasing this quality product. Be sure to check all packing material carefully for small part that may have come loose inside carton during shipment.

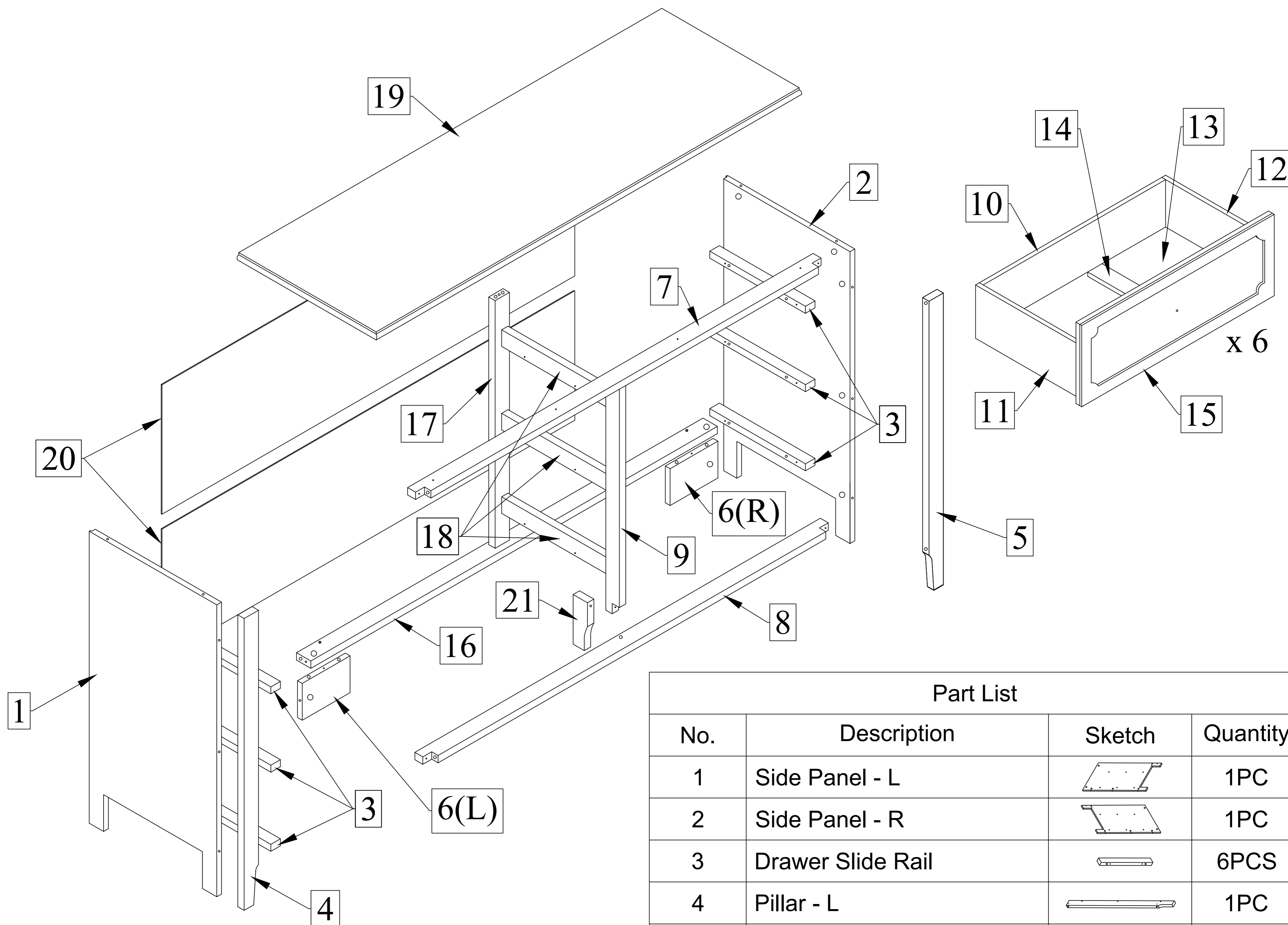

Part List

No.	Description	Sketch	Quantity
1	Side Panel - L		1PC
2	Side Panel - R		1PC
3	Drawer Slide Rail		6PCS
4	Pillar - L		1PC
5	Pillar - R		1PC
6	Leg (L & R)	L R	2PCS
7	Top Rail		1PC
8	Bottom Rail		1PC
9	Middle Rail (Front)		1PC
10	Drawer Back		6PCS
11	Drawer Side - L		6PCS
12	Drawer Side - R		6PCS
13	Drawer Base		6PCS
14	Drawer Base Support		6PCS
15	Drawer Front - 3L3R		6PCS
16	Back Rail		1PC
17	Middle Rail (Back)		1PC
18	Center Rail		3PCS
19	Top Panel		1PC
20	Back Panel		2PCS
21	Center Leg		1PC

TOOLS REQUIRED (Not provided)

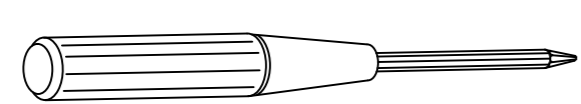

Screwdriver

Hardware List

No.	Description	Sketch	Quantity
A	Wood Dowel M8x30MM		40PCS
B	Minifix + Cap	B1 B2	14SETS
C	Wood Dowel M6x30MM		48PCS
D	Minifix + Cap [Drawer]	D1 D2	36SETS
E	H Connector		1PC
F	Screw M4 x 32MM		54PCS
G	Drawer Slide	G1 G2	6SETS
H	Screw M3 x 12MM		114PCS
I	Handle with Screw	I1 I2	6SETS

ASSEMBLY INSTRUCTIONS

Item No : WF299164AAK

Description : DRESSER

Thank you for purchasing this quality product. Be sure to check all packing material carefully for small part that may have come loose inside carton during shipment.

Step 1 : Attach Wood Dowel (A) and Minifix (B1) to parts (1,2,3,4,5,6,7,8,9,16,17,18,19) accordingly. Attached Wood Dowel (C) and Minifix [Drawer] (D1) to drawer box parts (10,11,12,15) accordingly. Slot Back Panel (20) into H Connector (E).

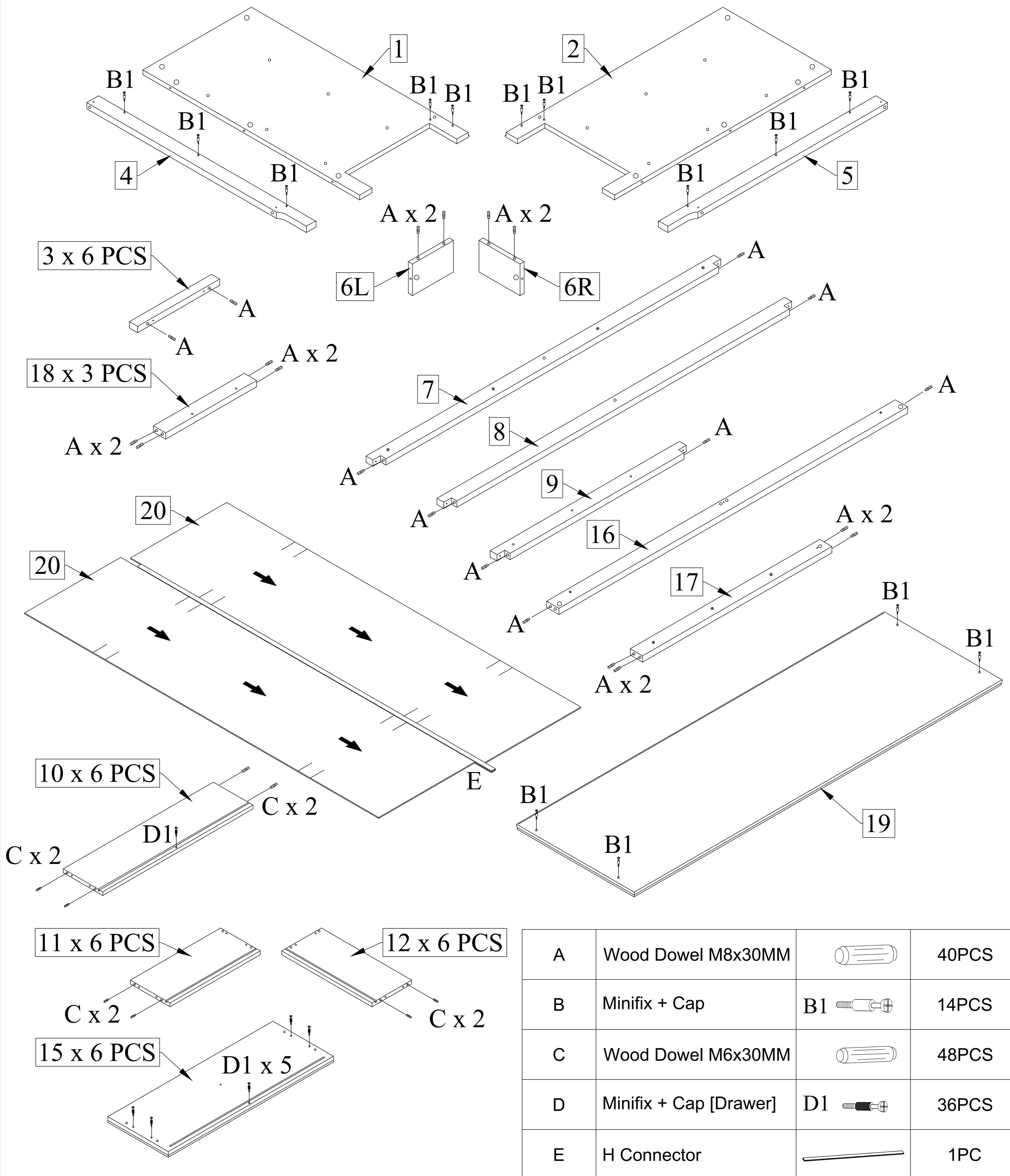

ASSEMBLY INSTRUCTIONS

Item No : WF299164AAK

Description : DRESSER

Thank you for purchasing this quality product. Be sure to check all packing material carefully for small part that may have come loose inside carton during shipment.

Step 2 : Connect Drawer Slide Rail (3) to Side Panel (1,2) with Screw (F).

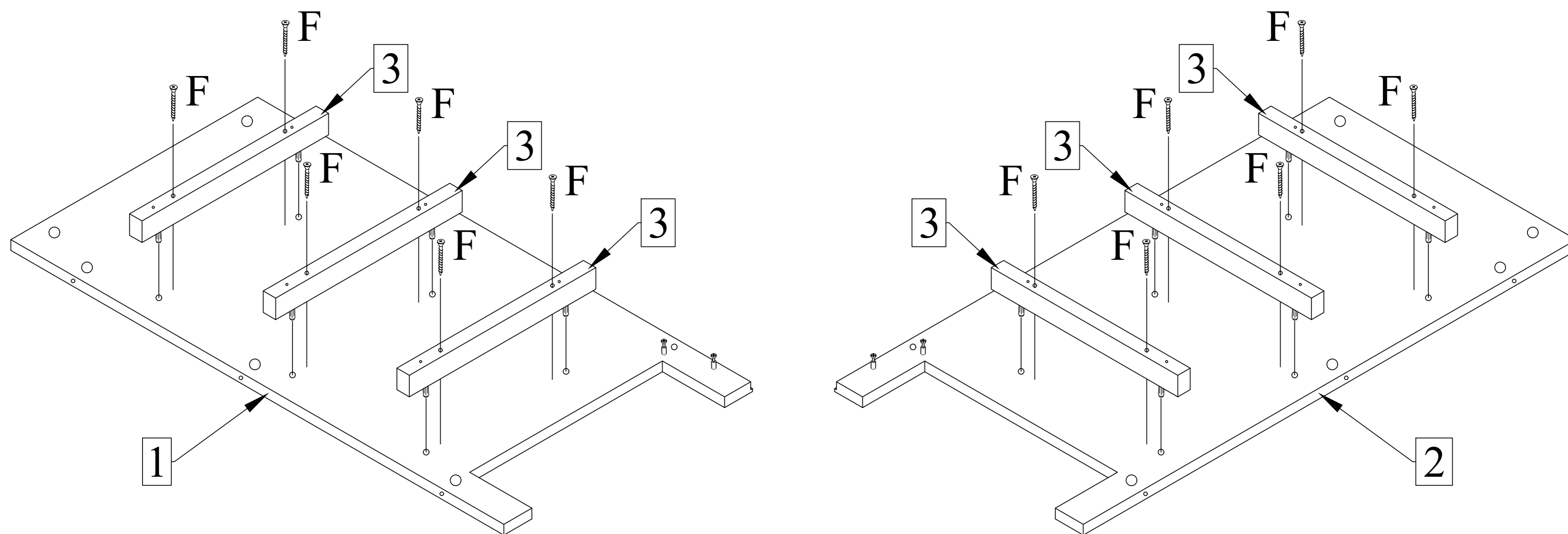

F	Screw M4 x 32MM		12PCS
---	-----------------	---	-------

Step 3 : Attach Drawer Slide (G1) onto the Rail on Side Panel using Screw (H).

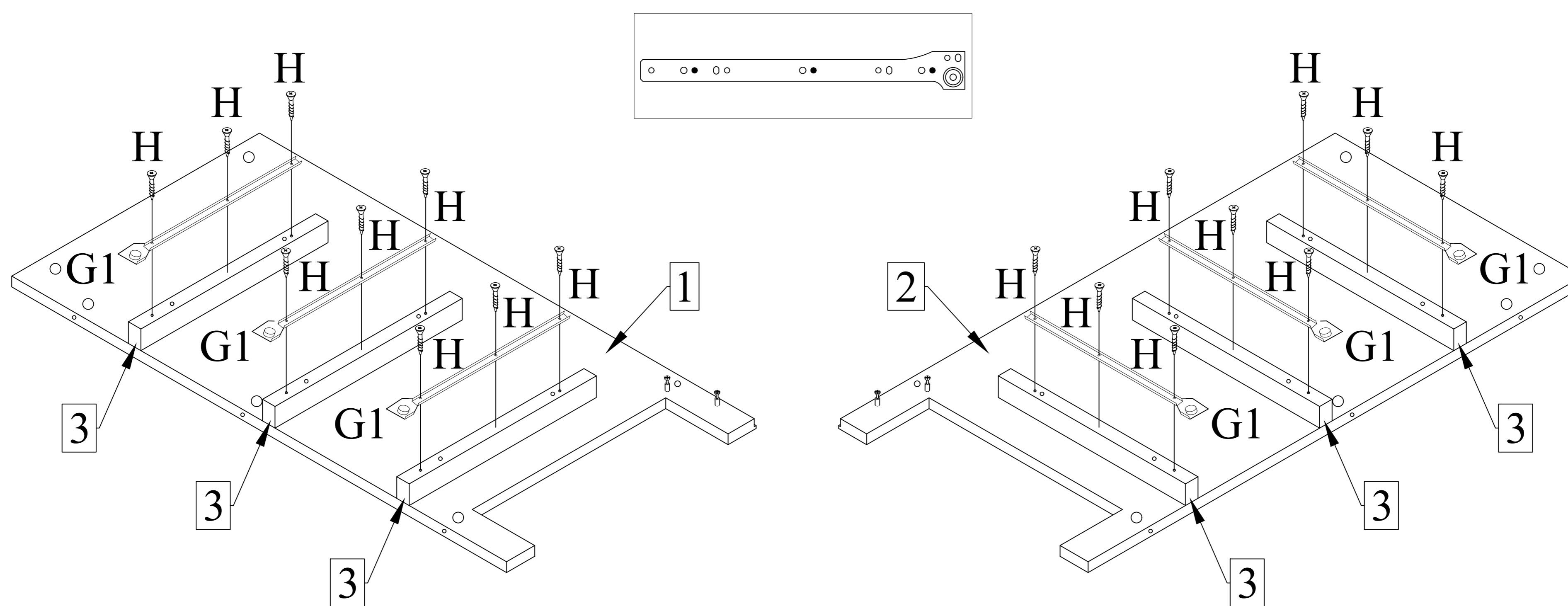

G	Drawer Slide		3SETS
H	Screw M3 x 12MM		18PCS

ASSEMBLY INSTRUCTIONS

Item No : WF299164AAK

Description : DRESSER

Thank you for purchasing this quality product. Be sure to check all packing material carefully for small part that may have come loose inside carton during shipment.

Step 4 : Connect Pillar (4,5) to Side Panel and lock Minifix Cap (B2).

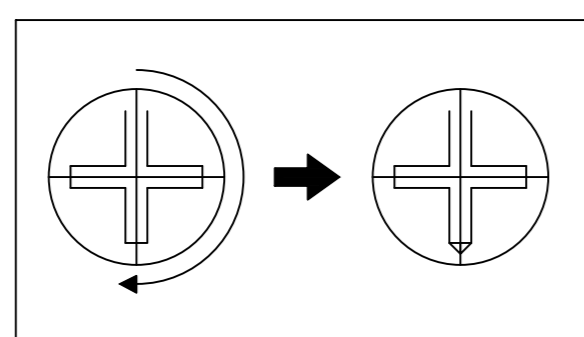
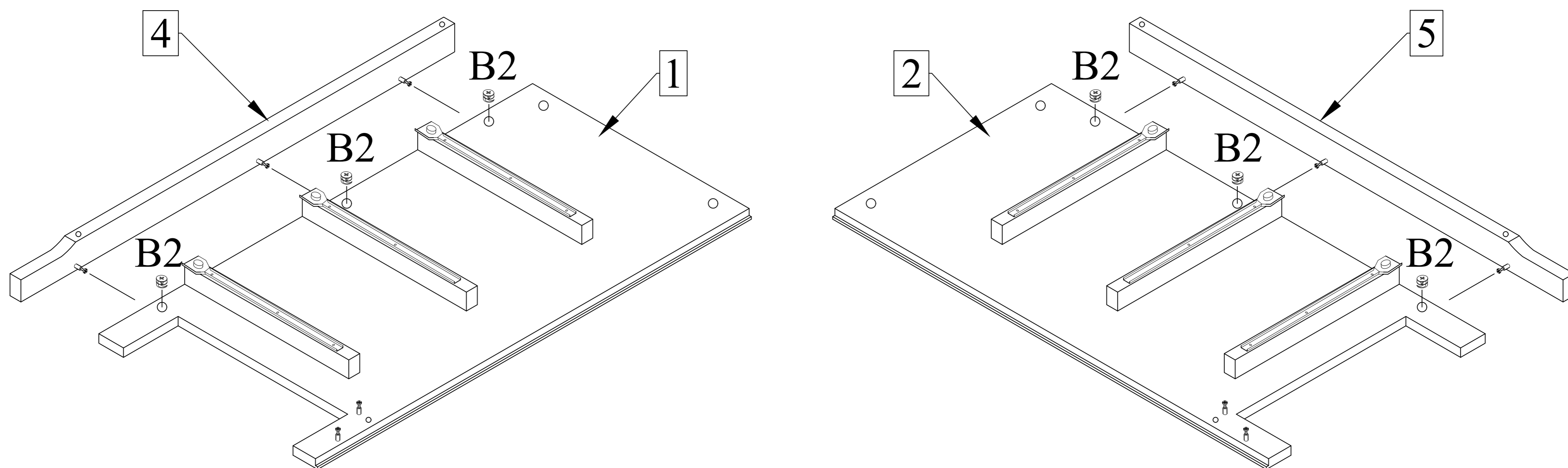

Lock Minifix cap clockwise

B	Minifix Cap	B2 	6PCS
---	-------------	--	------

Step 5 : Attach Drawer Slide (G1) to Center Rail (18) with Screw (H). Connect the Center Rail (18) to Middle Rails (9,17) with Screw (F,H). Attach Leg (6) onto Back Rail (16) using Screw (F). Then, connect these connected parts with Top & Bottom Rails (7,8) with Screw (F).

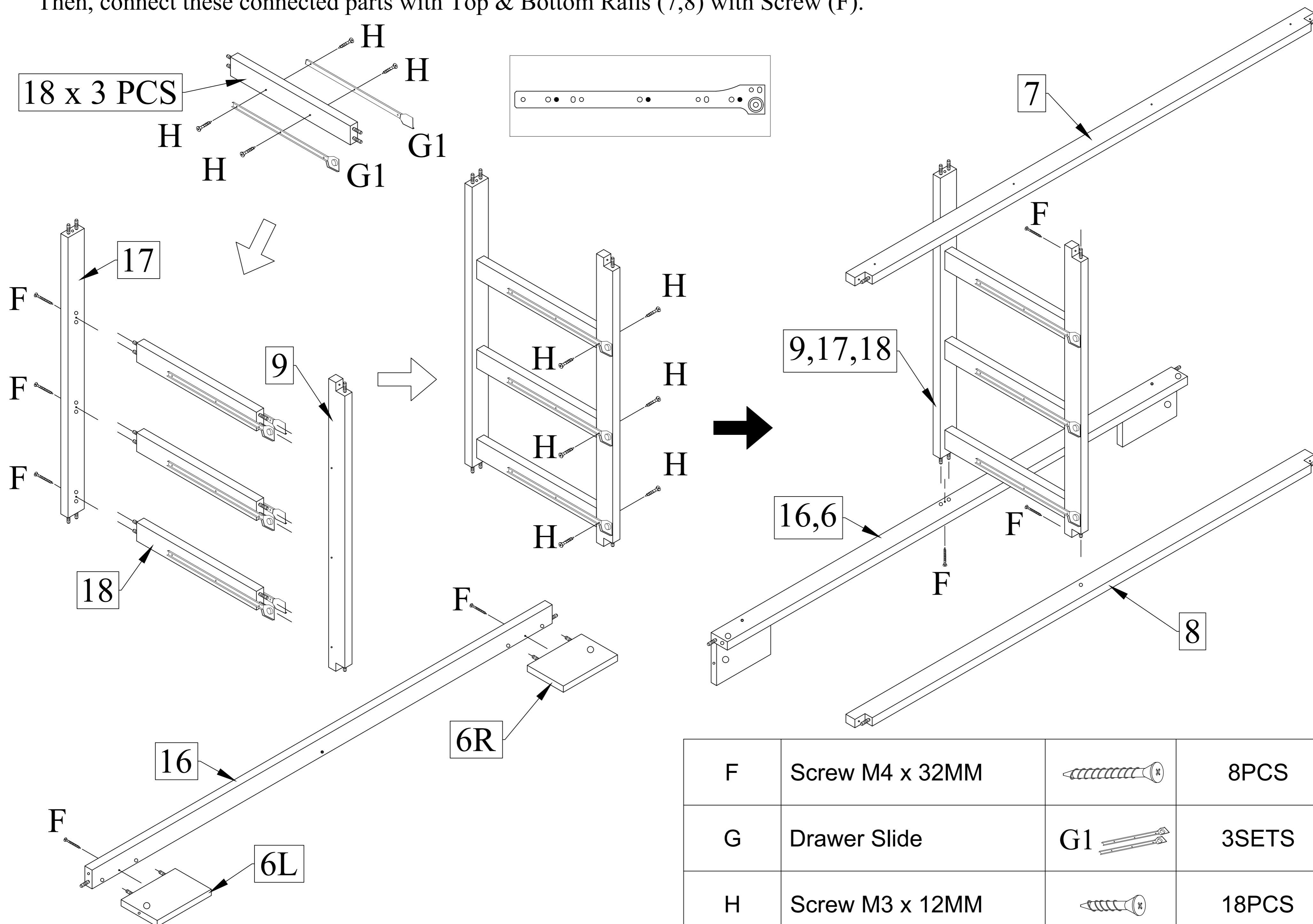

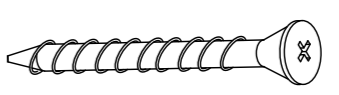
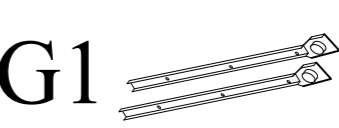
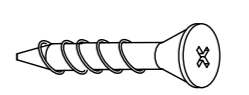
F	Screw M4 x 32MM		8PCS
G	Drawer Slide	G1 	3SETS
H	Screw M3 x 12MM		18PCS

ASSEMBLY INSTRUCTIONS

Item No : WF299164AAK

Description : DRESSER

Thank you for purchasing this quality product. Be sure to check all packing material carefully for small part that may have come loose inside carton during shipment.

Step 6 : Attach Center Leg (21) onto the connected parts with Screw (F).
Connect Side Panels (1,2) with Screw (F) and lock Minifix Cap (B2).

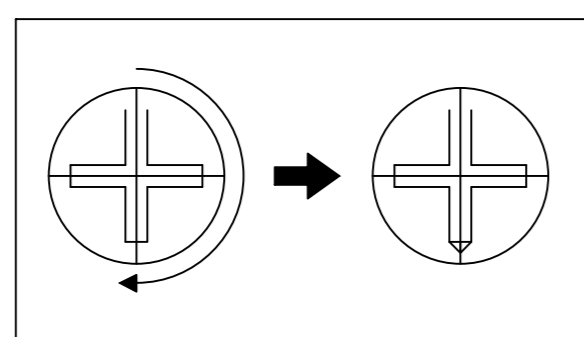
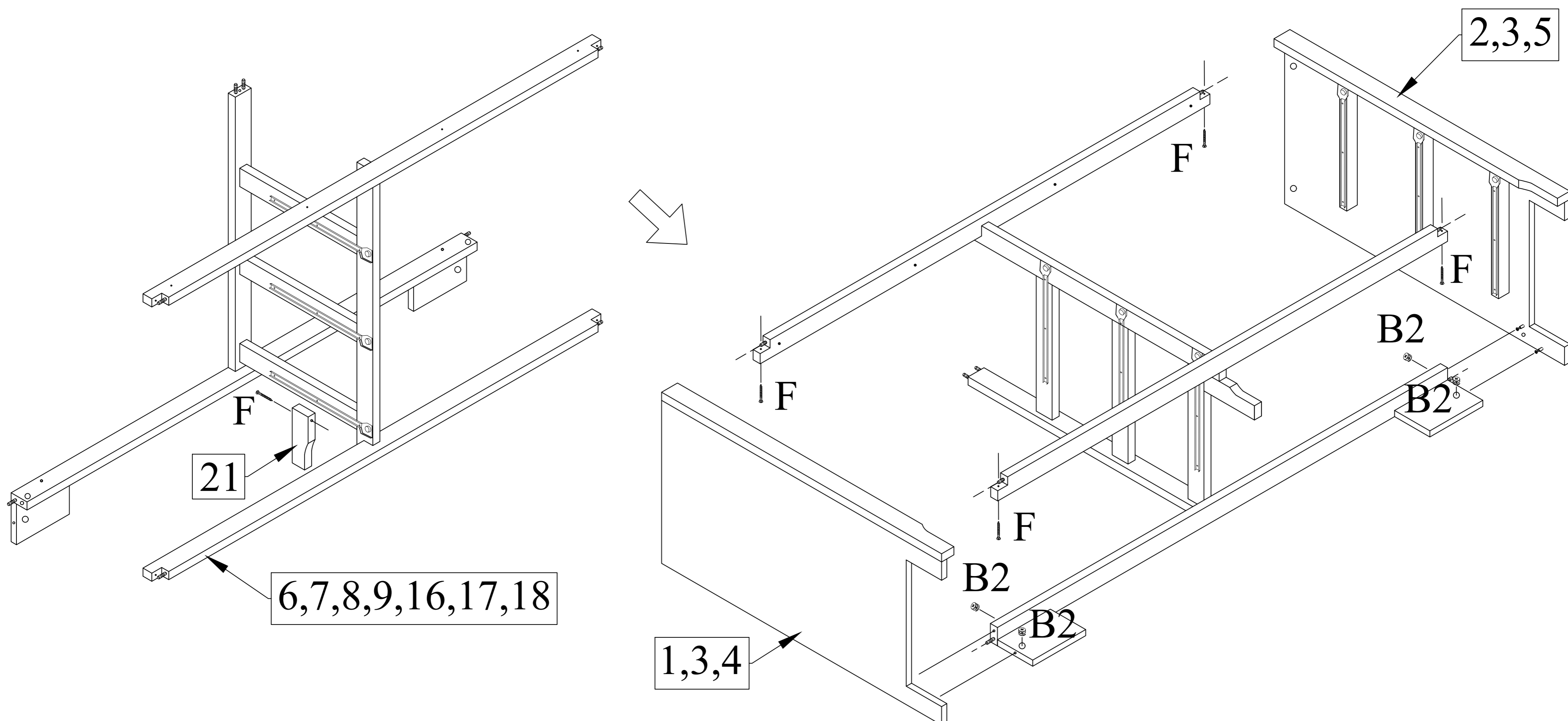

Lock Minifix cap clockwise

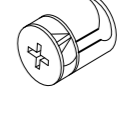
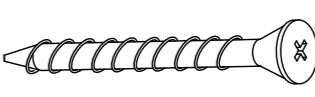
B	Minifix Cap	B2 	4PCS
F	Screw M4 x 32MM		5PCS

Step 7 : Attach Top Panel (19) and lock with Minifix Cap (B2) and Screw (F).

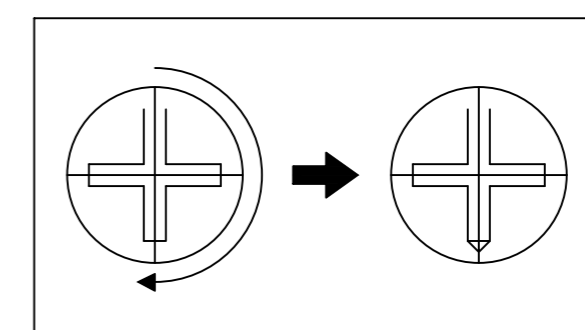
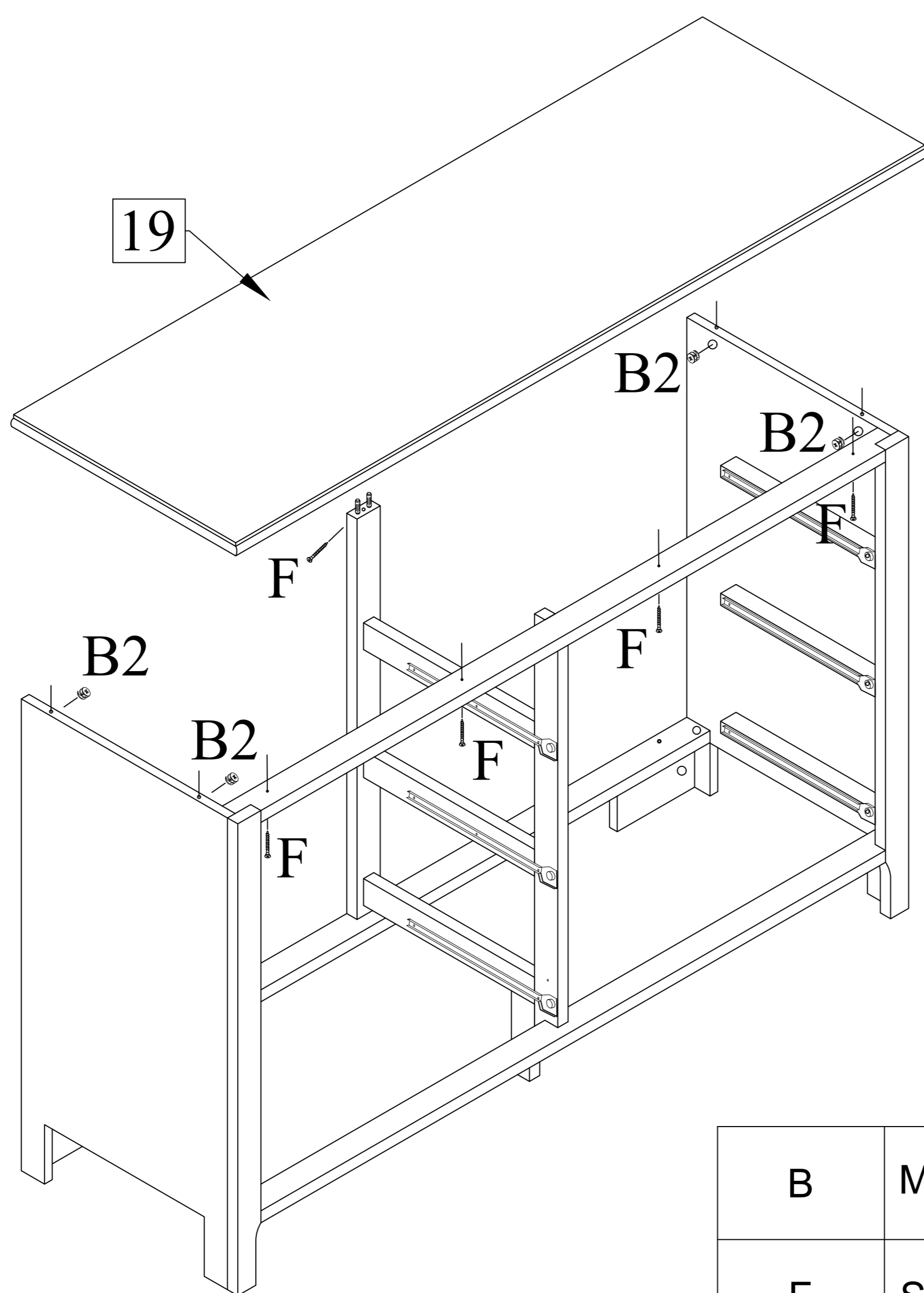

Lock Minifix cap clockwise

B	Minifix Cap	B2 	4PCS
F	Screw M4 x 32MM		5PCS

ASSEMBLY INSTRUCTIONS

Item No : WF299164AAK

Description : DRESSER

Thank you for purchasing this quality product. Be sure to check all packing material carefully for small part that may have come loose inside carton during shipment.

Step 8 : Insert Back Panel (20) from behind using Screw (H).

Make sure marking line on back panel facing out, it will be a guidance to attach matching mirror WF299174AAK

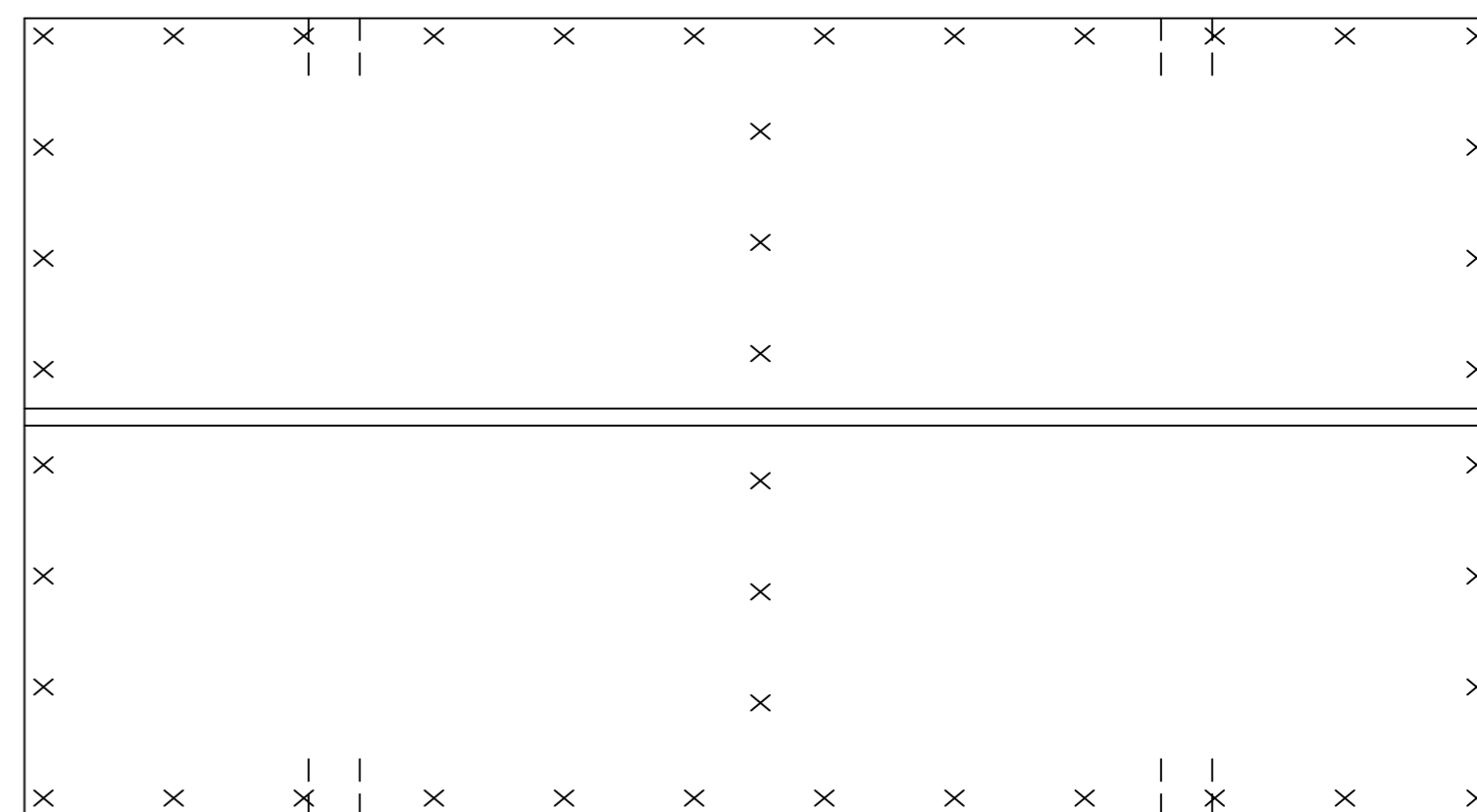
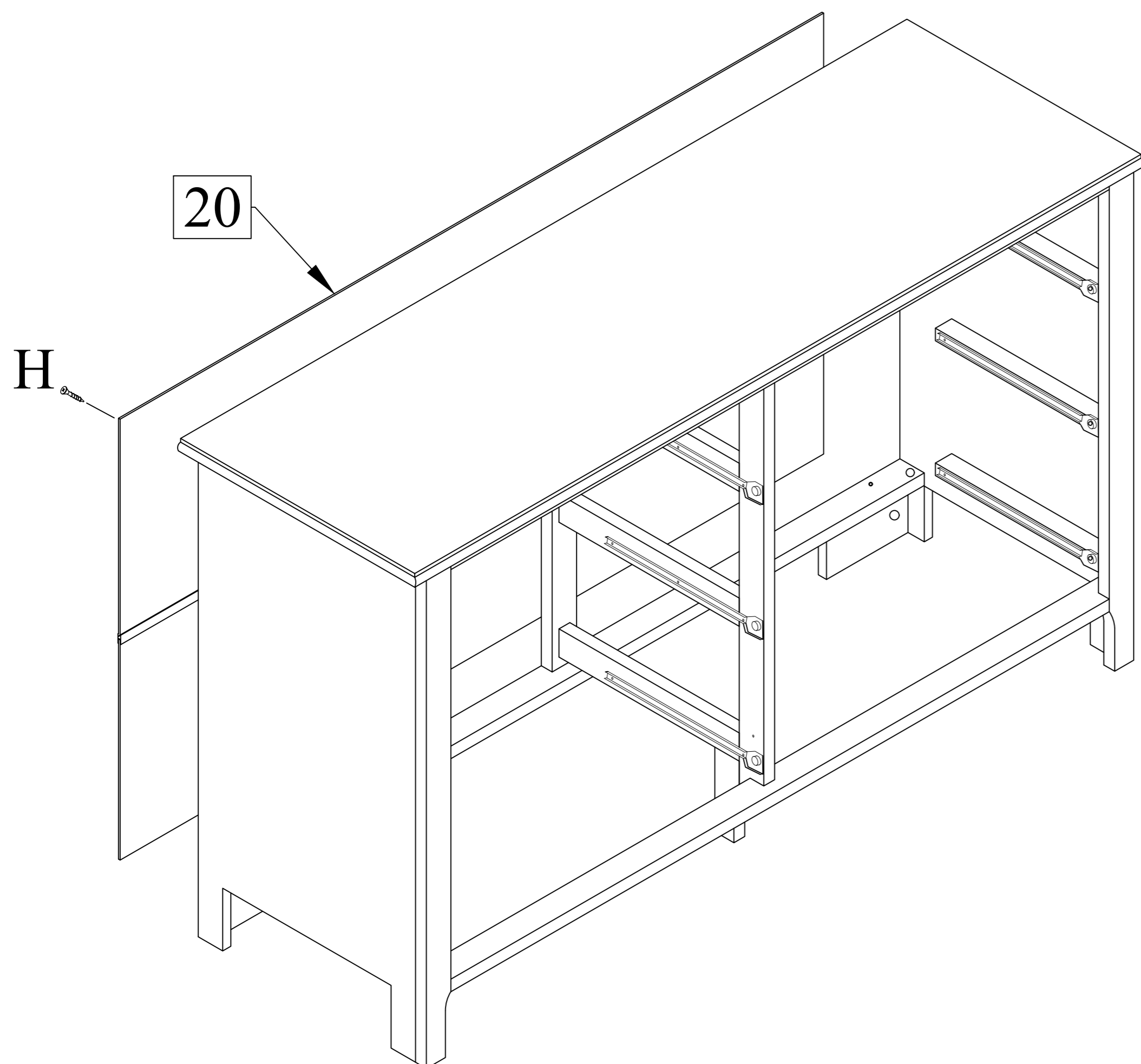

Guidance of screw array

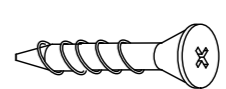
H	Screw M3 x 12MM		42PCS
---	-----------------	---	-------

Step 9 : Drawer assembly.

First connect Drawer Back (10) to Drawer Side - L (11) and Drawer Side - R (12) with Screw (F).

Slot the Drawer Base Support (14) into Drawer Back (10). Next, slot in the Drawer Base (13).



Then, install the Handle with Screw (I1&I2) onto Drawer Front (15). Attach the Drawer Front (15) to the drawer box and lock Minifix Cap [Drawer] (D2).

Finally, install Drawer Slide (G2) onto the drawer box using Screw (H).

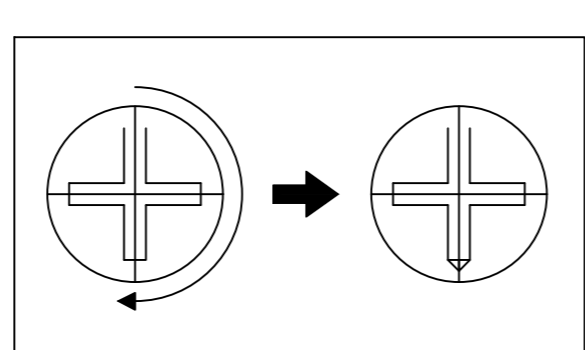
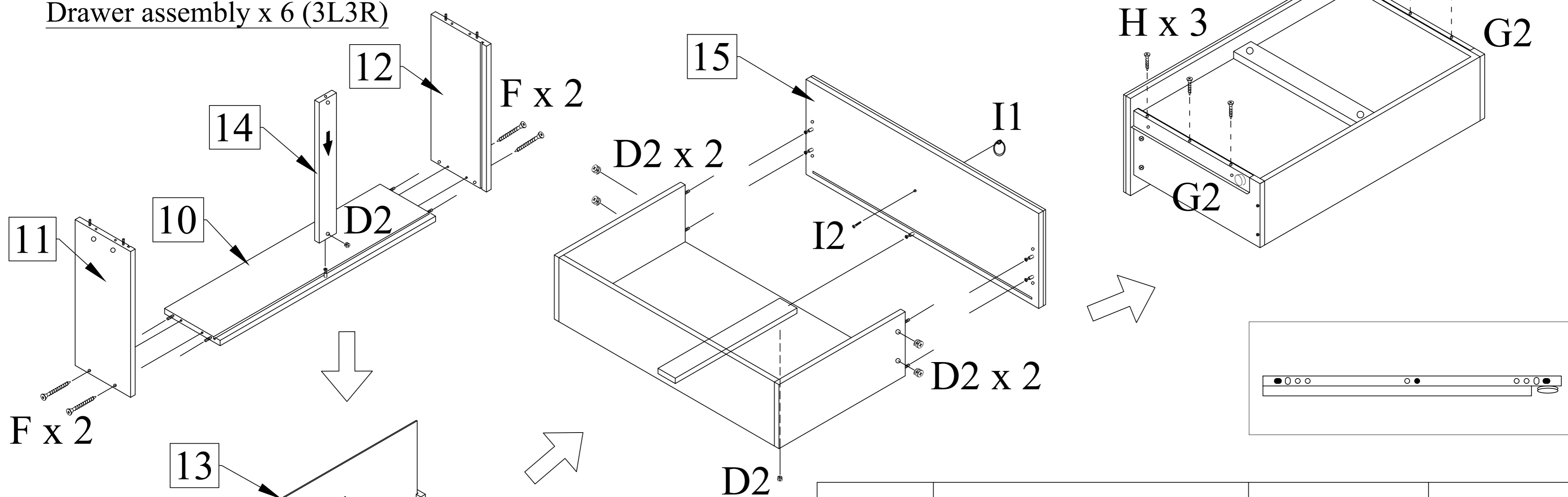
Drawer assembly x 6 (3L3R)

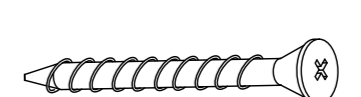
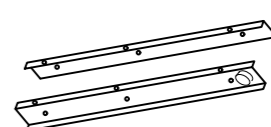
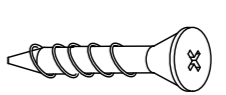

Lock Minifix cap clockwise

D	Minifix Cap [Drawer]	D2 	36PCS
F	Screw M4 x 32MM		24PCS
G	Drawer Slide	G2 	6SETS
H	Screw M3 x 12MM		36PCS
I	Handle with Screw	I1  I2 	6SETS

ASSEMBLY INSTRUCTIONS

Item No : WF299164AAK

Description : DRESSER

Thank you for purchasing this quality product. Be sure to check all packing material carefully for small part that may have come loose inside carton during shipment.

Step 10 : Insert the drawer box.

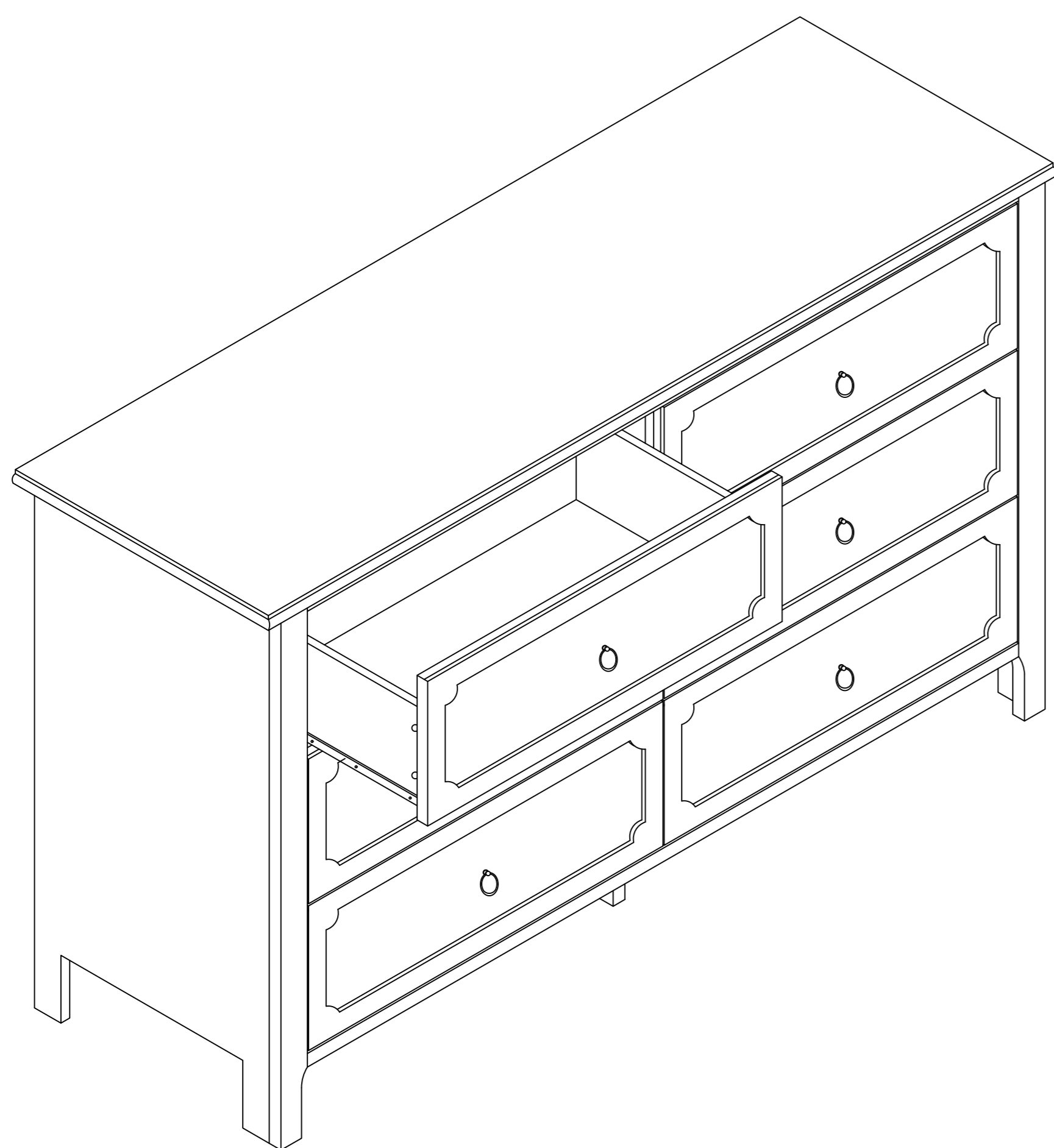

ANCHORING DRESSER

To anchor your dresser, use the anchor kit as seen in the diagram below. Choose a suitable wall fixing that matches your wall style and then fasten the strap to the wall as shown using appropriate fixings.

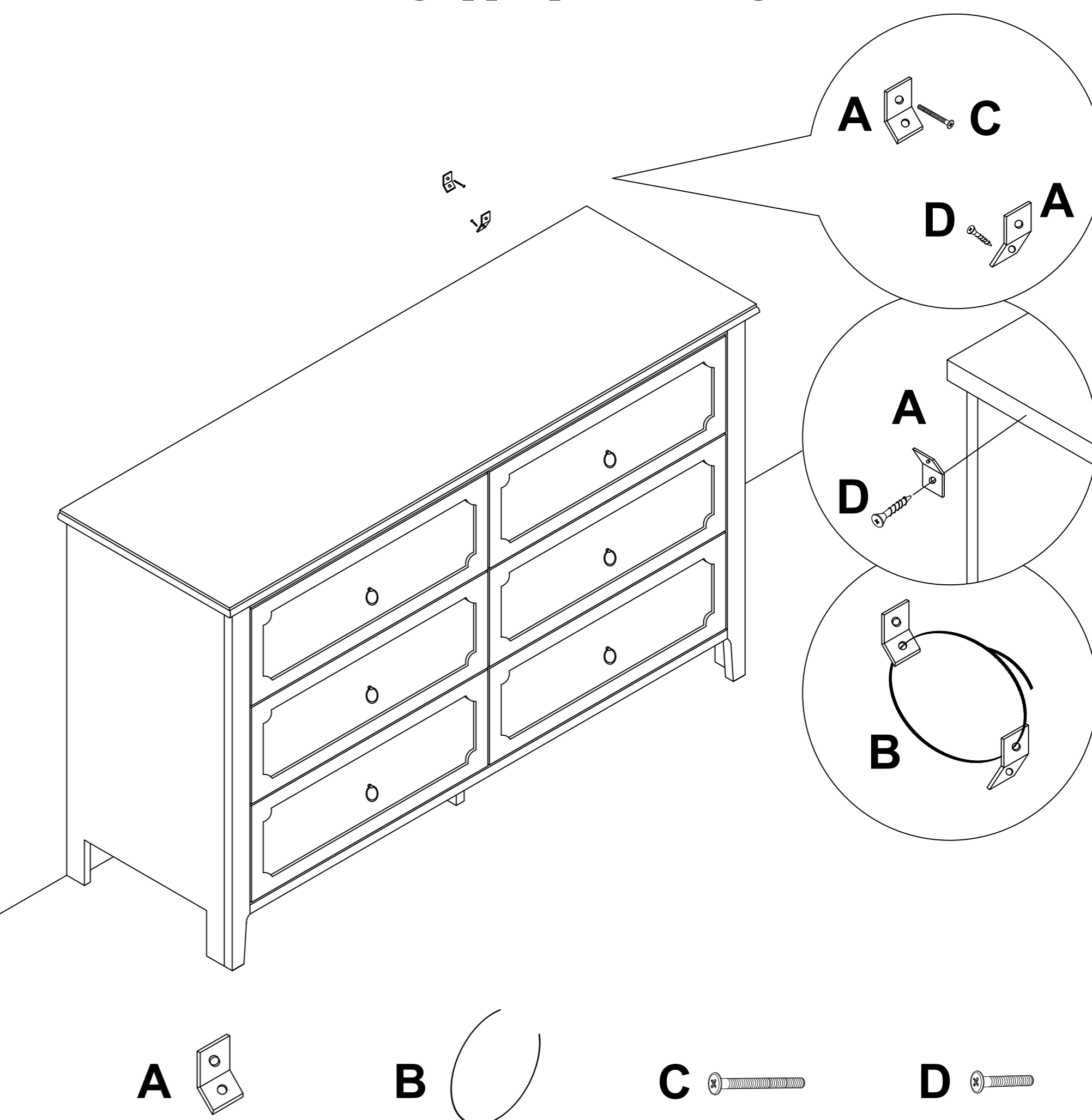

Completed assembly.

