

# MANUAL INSTRUCTION

TV Stand

PXYJHM044MS-A

PXYJHM044WH-A

PXYJHM044BK-A

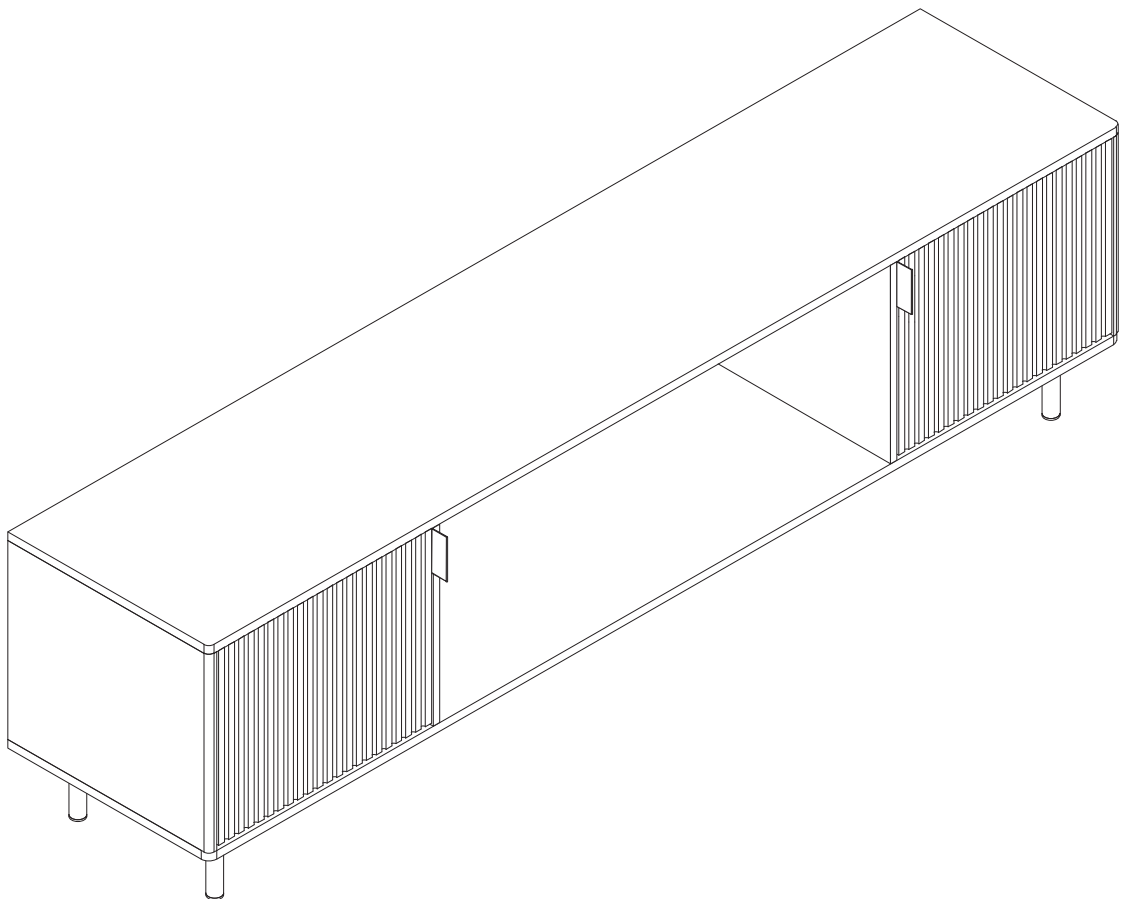

TV Stand PXYJHM044MS-A PXYJHM044WH-A PXYJHM044BK-A



**We offer a diverse range of  
products  
to meet the needs of customers**

- 1. The product must be assembled and used in accordance with the provisions of the manual. The seller does not assume any responsibility or liability with respect to any damage caused by incorrect assembly or improper use.**
- 2. Periodically inspect screw tightness while the product is in use. If necessary, retighten to ensure structural integrity.**
- 3. Please read assembly instructions before start.**
- 4. Please remember : This summary may not include every detail of all variations or considered steps.**

## **Warnings**

- 1. It is strictly prohibited to sit or stand on the product.**
- 2. Please put this item on a flat ground.**
- 3. During the assembly process, keep any small parts out of the reach of children. It may be fatal if swallowed or inhaled**
- 4. To avoid the potential dangers of suffocation, please keep all parts and packaging (films, plastic bags and foam, etc.) away from babies and children.**
- 5. If there is/are defective and/or missing part(s) after unpacking, please cease assembly immediately and get in contact with us as soon as possible.**

## **Tools Required**

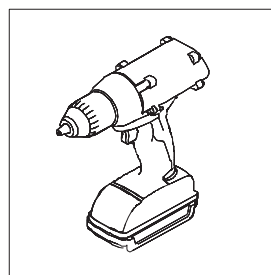
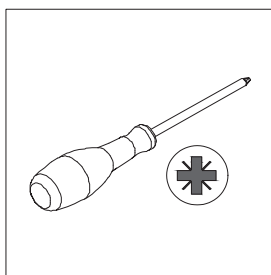
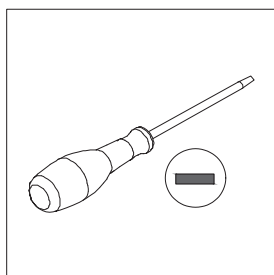
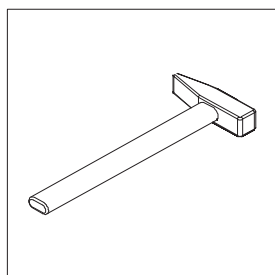

**If electric tools are required, please reduce the torque to prevent product damage during installation.**

# PARTS

 2 Persons Assembly

 Up to 60 Minutes For Assembly



When installing, please carefully confirm whether each screw corresponds to the manual, accessories with similar shapes can be distinguished by size.

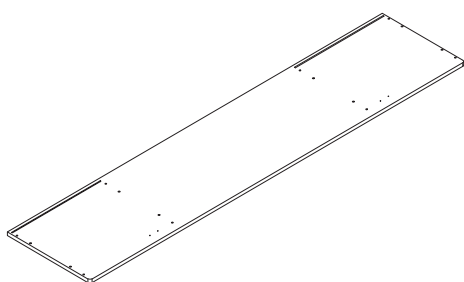

1 x1

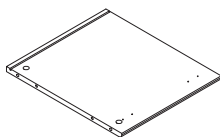

2 x1

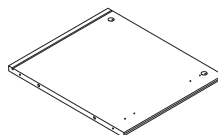

3 x1

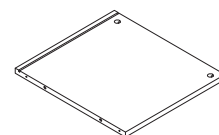

4 x1

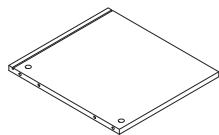

5 x1

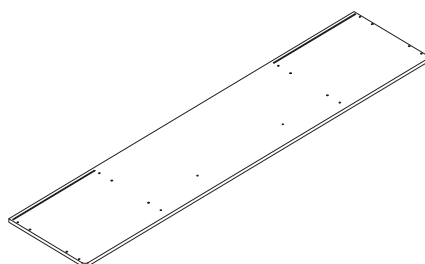

6 x1

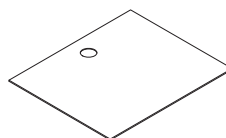

7 x2

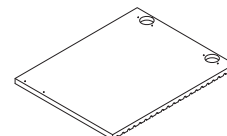

8 x1

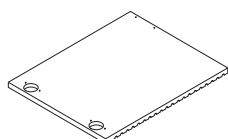

9 x1

# HARDWARE



Φ6x35mm

**A** x8



Φ15x9mm

**B** x8

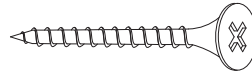

M4x40mm

**C** x8



Φ6x30mm

**D** x16



M3x14mm

**E** x4

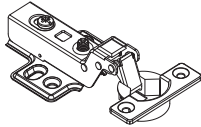

Φ35mm

**F** x4



M3.5x14mm

**G** x24

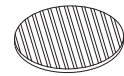

Φ20mm

**H** x8

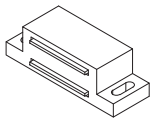

**I** x2

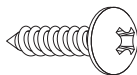

M4x14mm

**J** x24

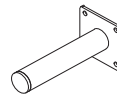

**K** x4

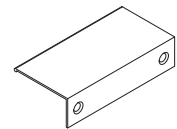

**L** x2



M3x12mm

**M** x4

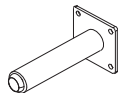

**N** x2

# EXPLOSION DIAGRAM

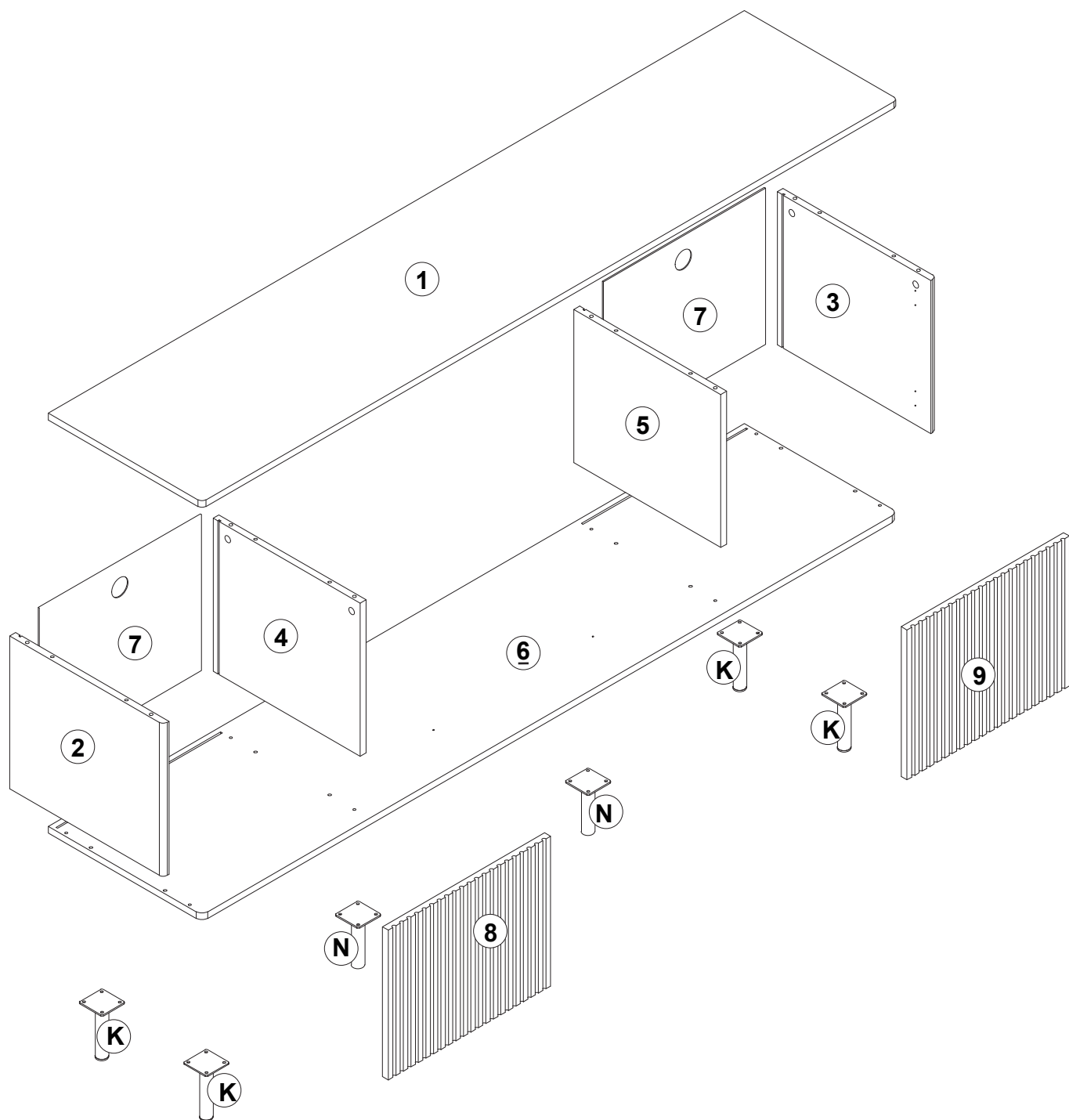

1

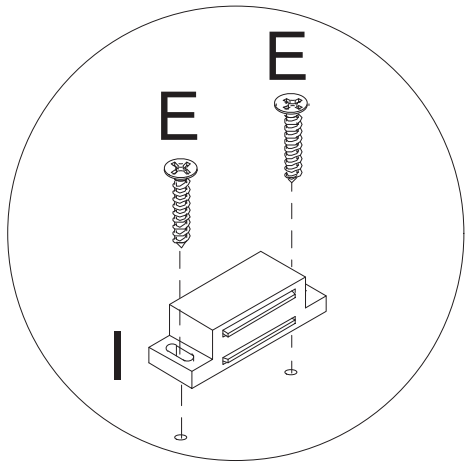
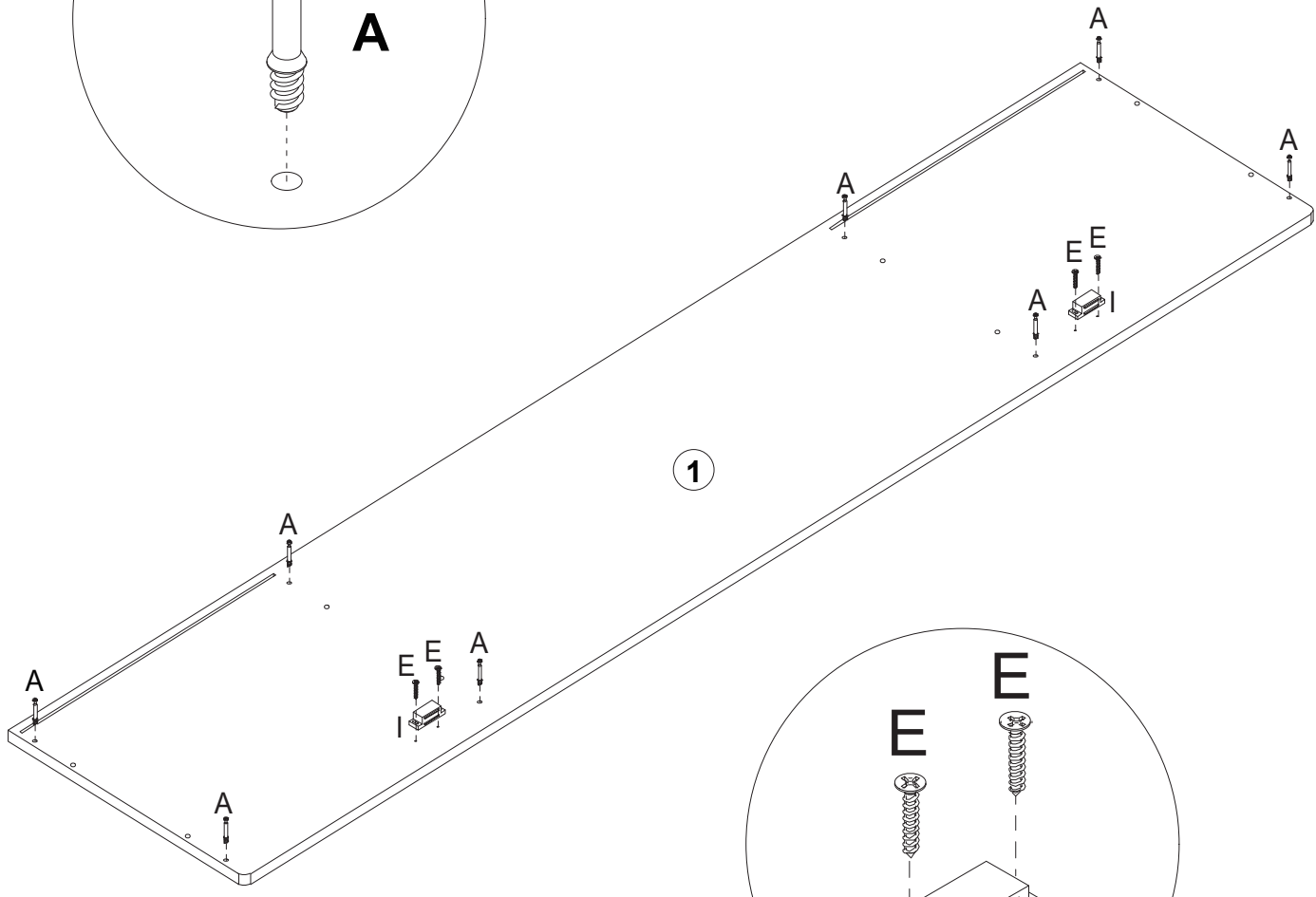
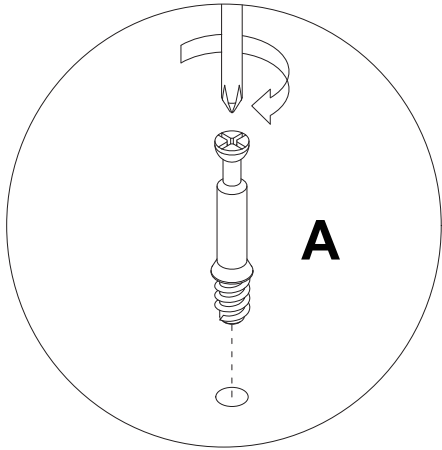
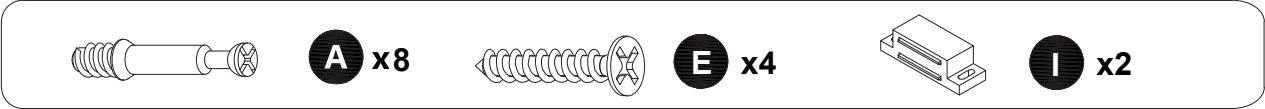

2

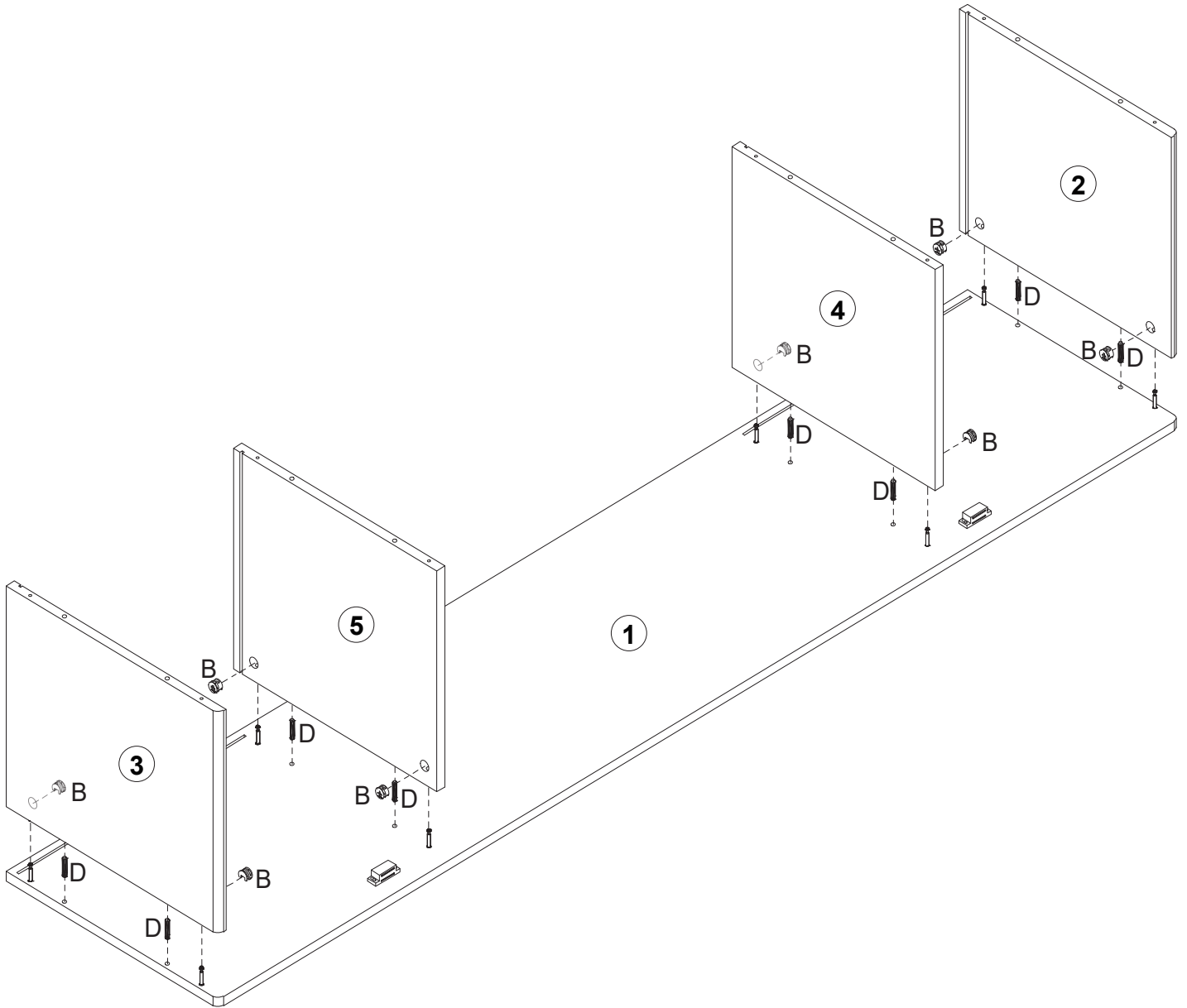
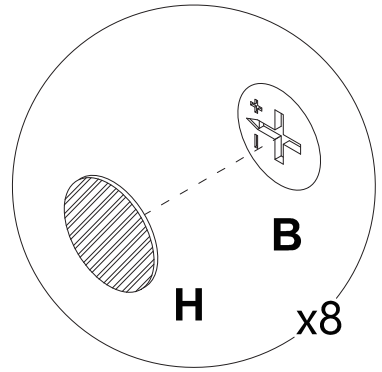
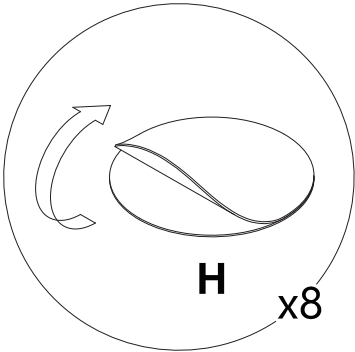
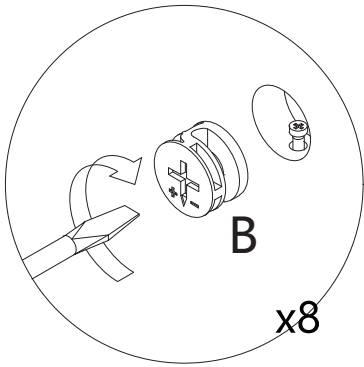
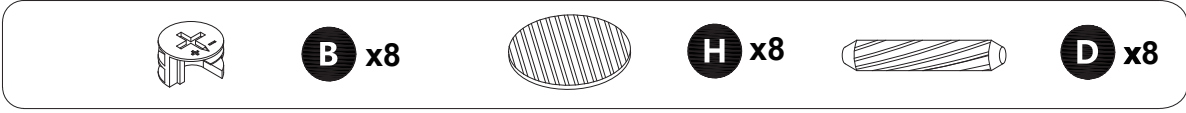

3



**D** x8

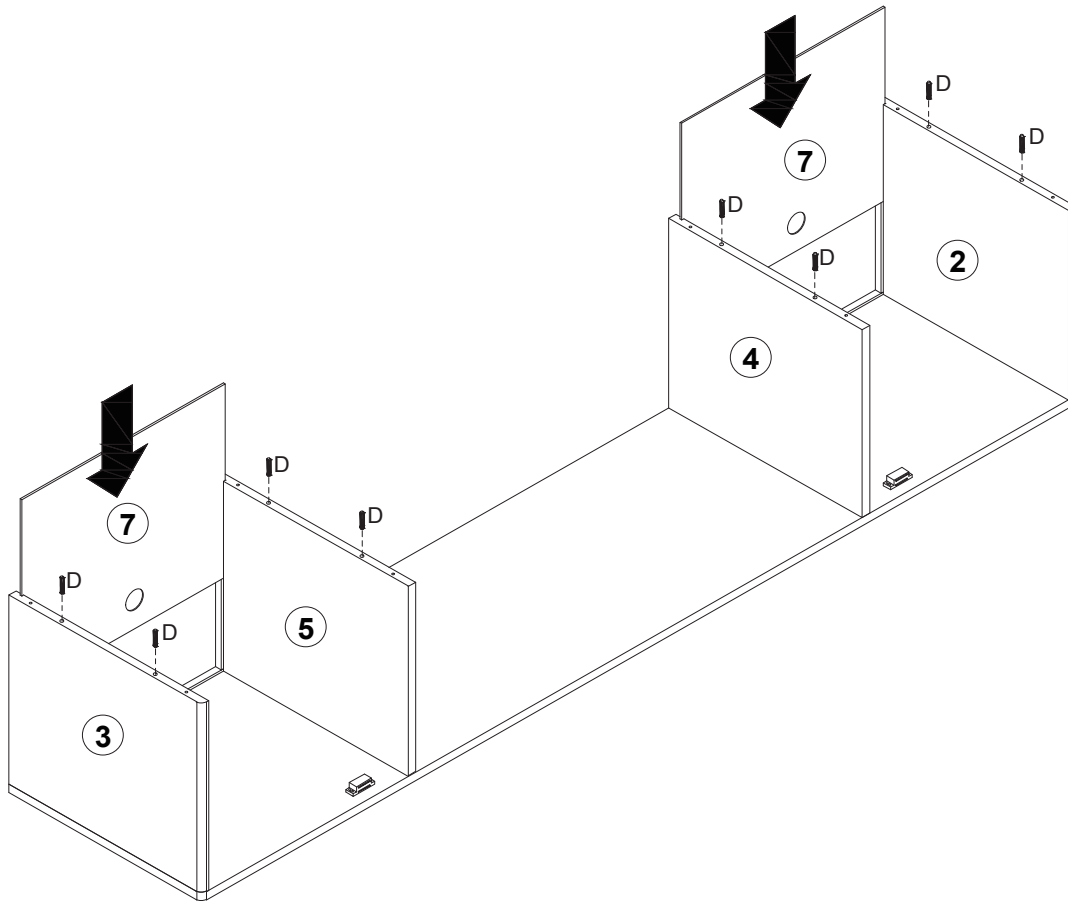

4



**C** x8

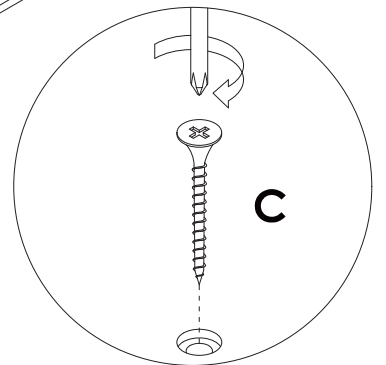
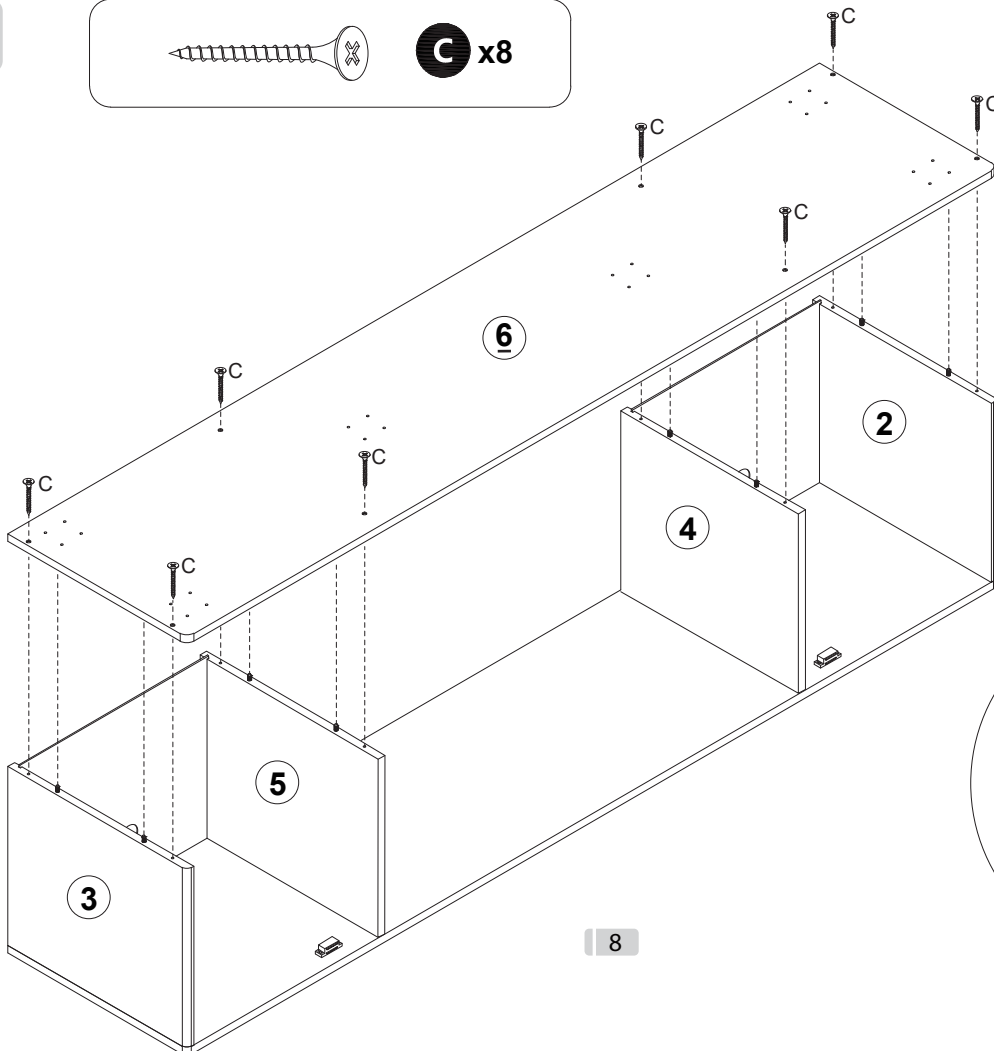

5

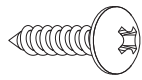

**J** x24

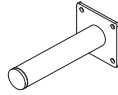

**K** x4

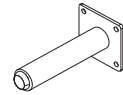

**N** x2

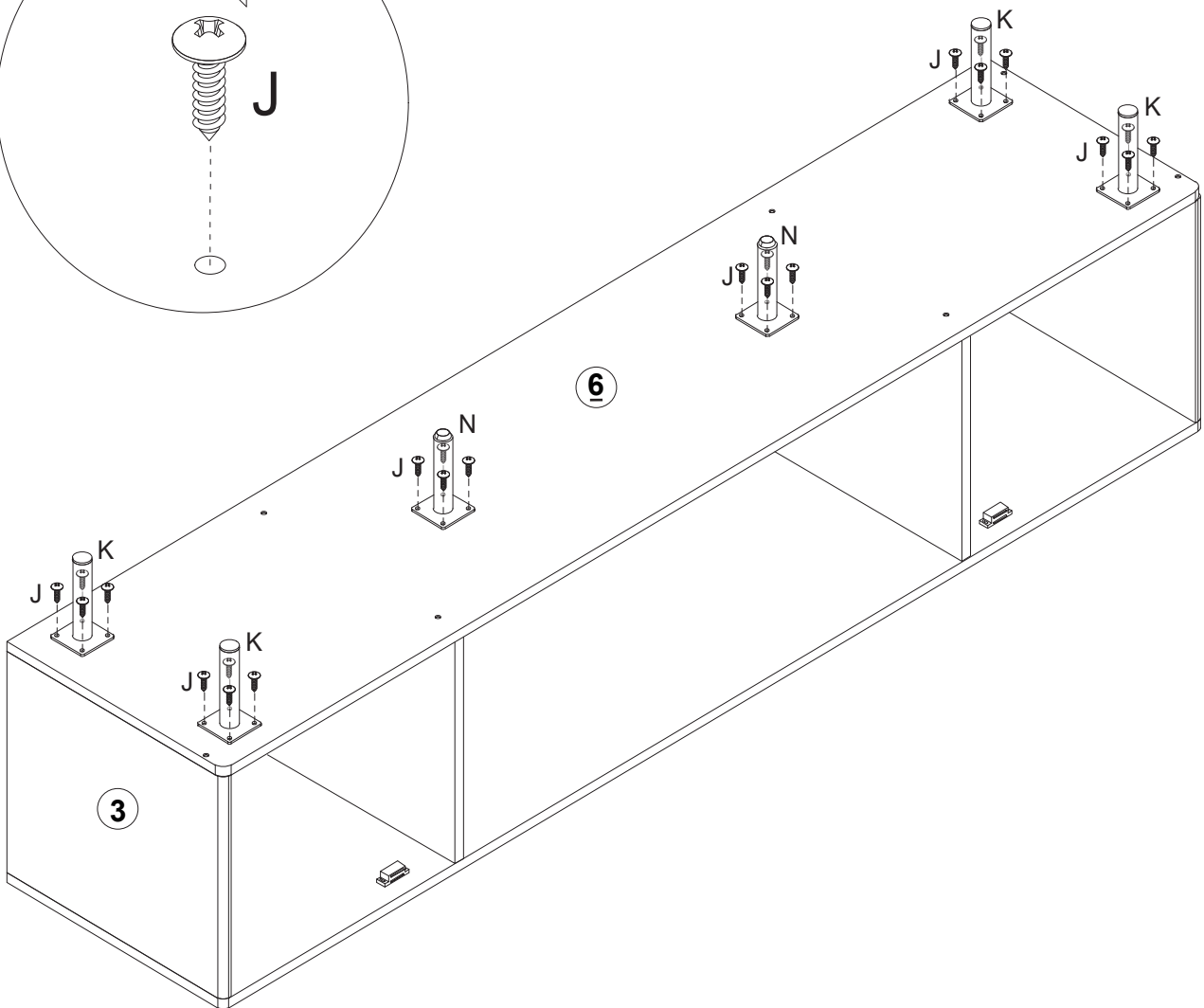
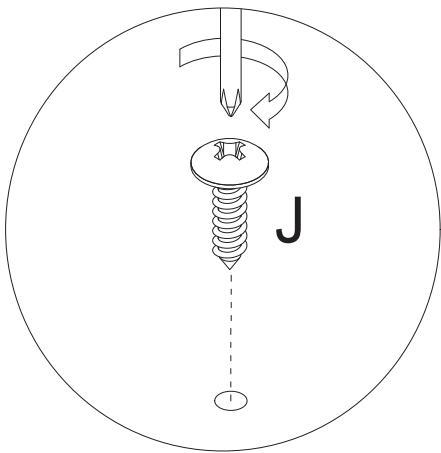

6

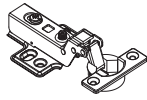

F x4



G x8

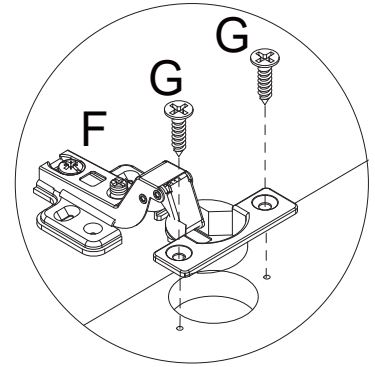
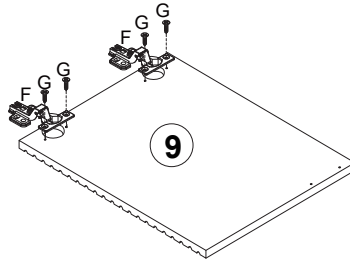
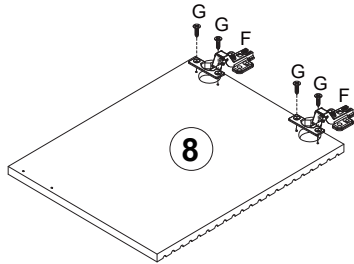

7



G x16

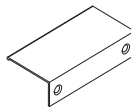

L x2



M x4

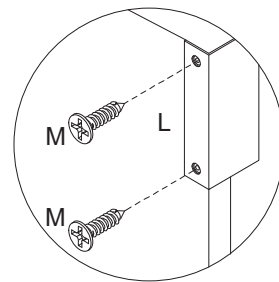
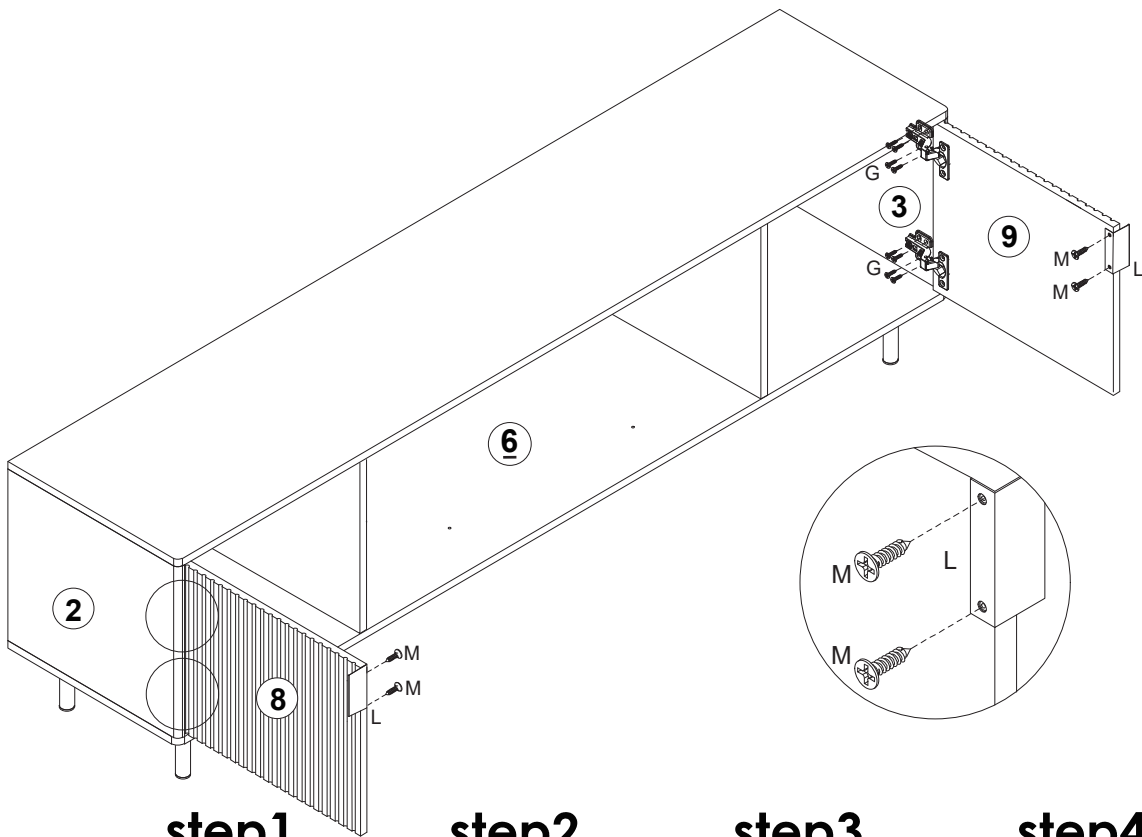

step 1

step 2

step 3

step 4

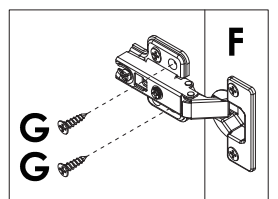
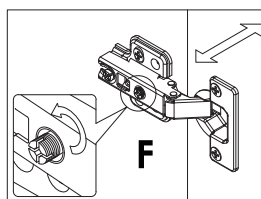
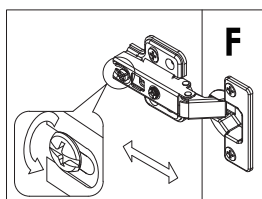
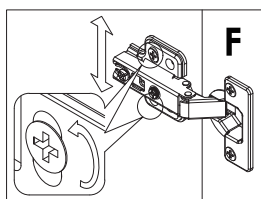
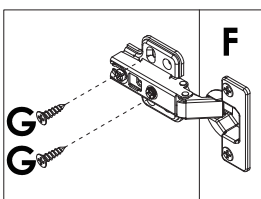

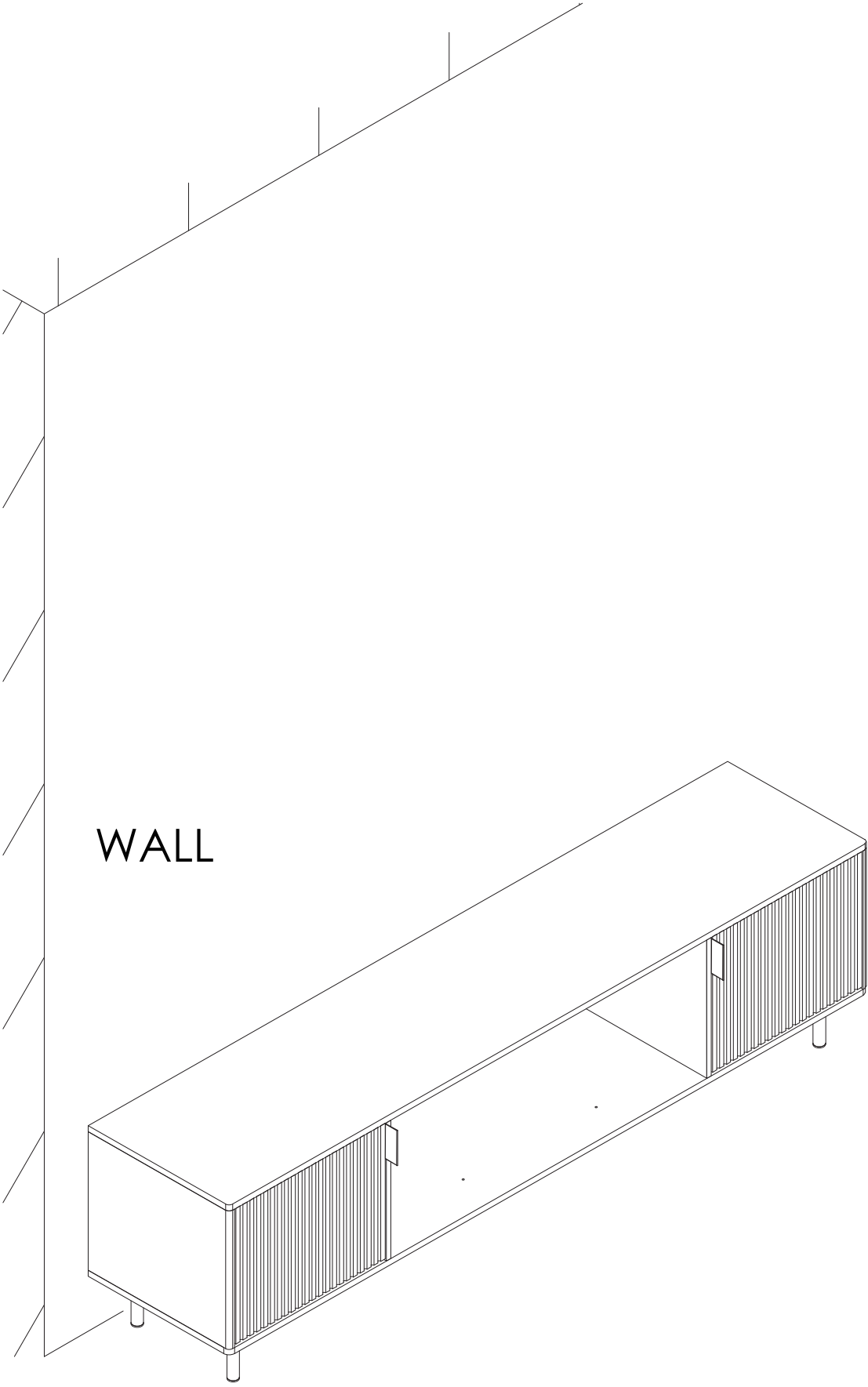

9

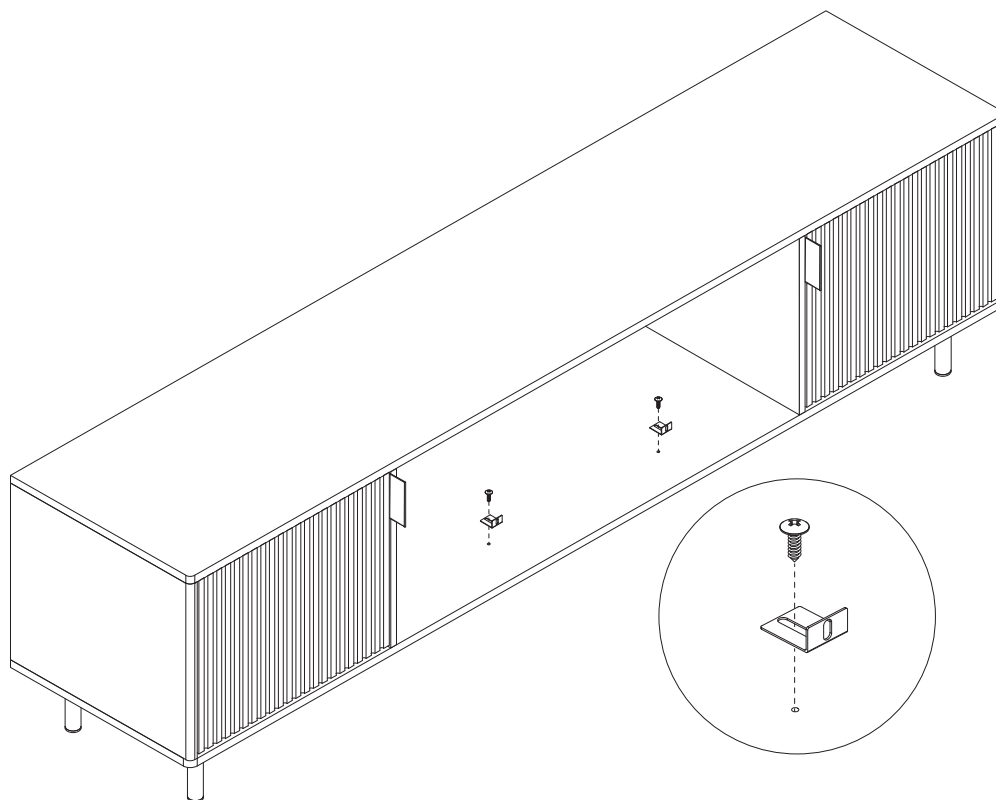

10

The gently put the appliance to the TV Stand by two persons.

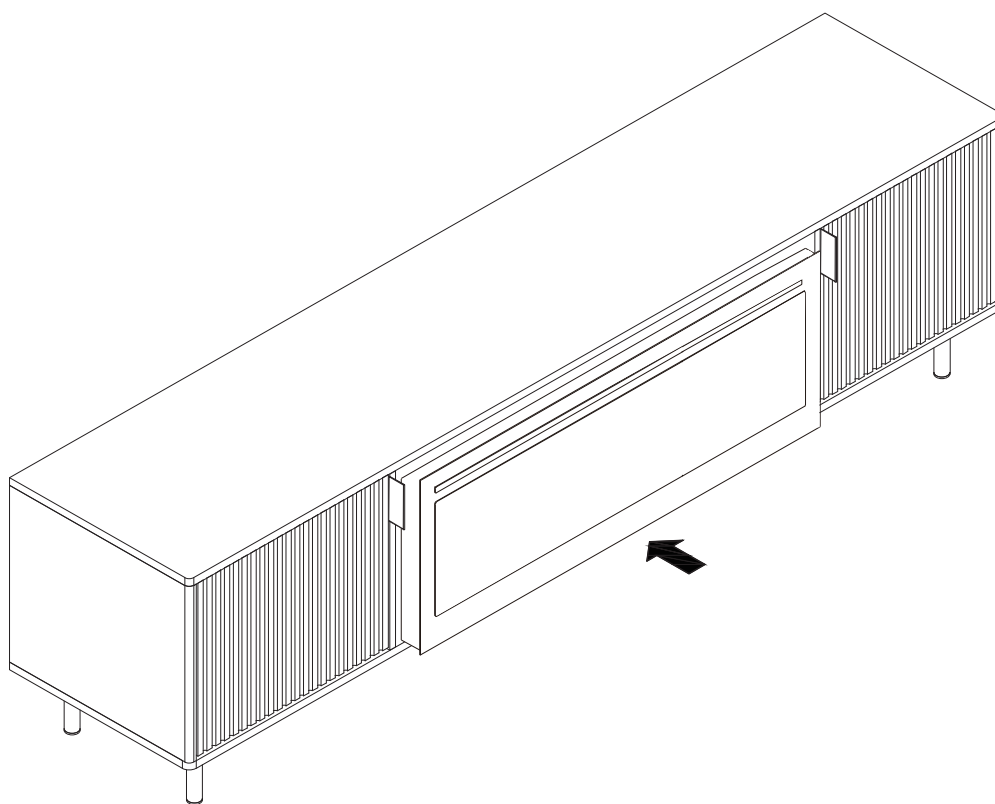

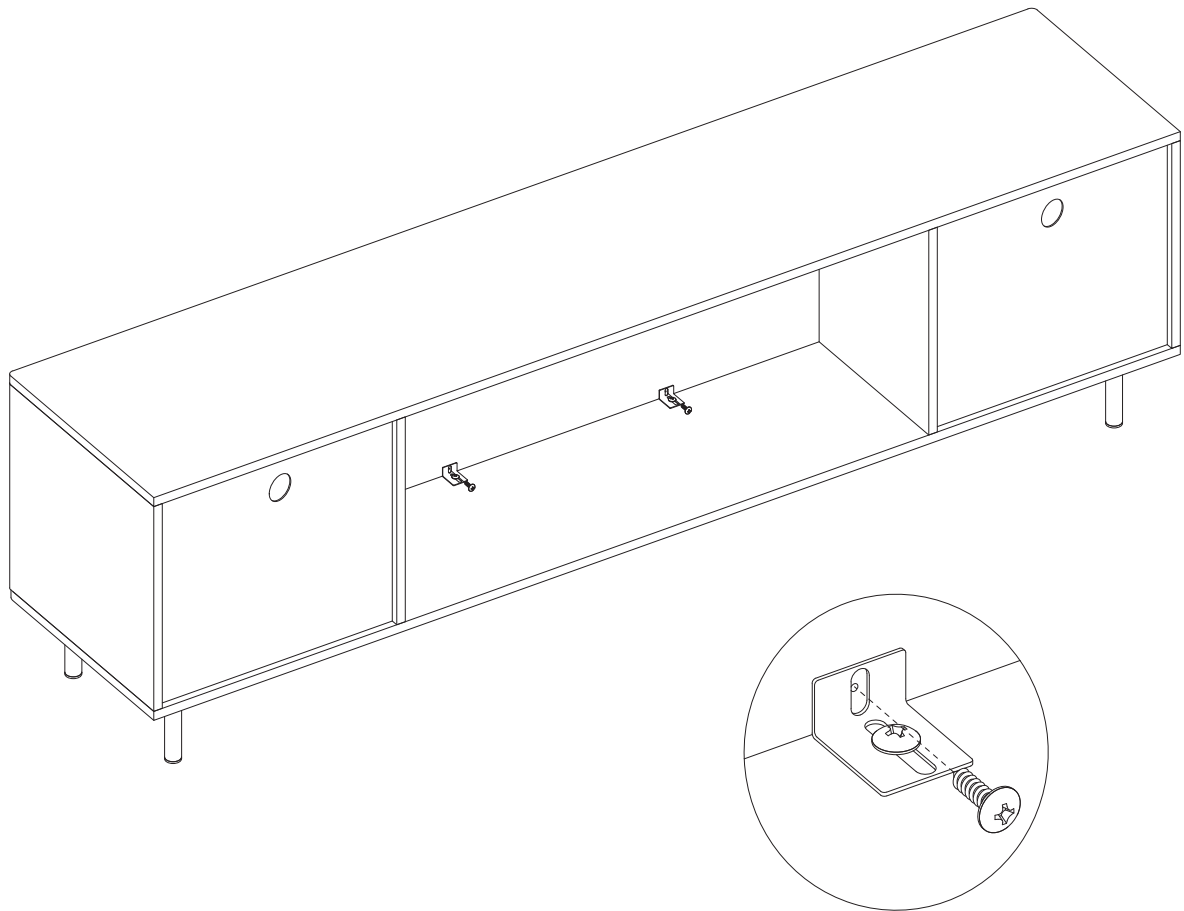

# HELP CENTER

Question about your product? We're here to help. Visit us at:

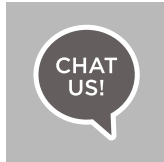

Chat Support



Product Inquiry

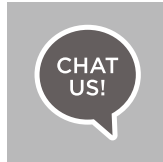

Orders FAQ



Product Assembly



Returns & Refunds

## We Stand Behind the Quality of The Furniture

If you have any issues with your item please let us know!

We will always do our best to come up with a solution that you will be happy with.

Please get in touch with our customer service team before returning the product.

And pls do not throw the original box (es) if you have not finished assembling or confirmed no quality issues.

Length of return period:

Items can be returned within 30 days of purchase.

We will cover the return shipping fees or resend parts/product if:

1. Your item has a manufacturing defect in its materials or workmanship. For example, torn wicker or misaligned screw holes. We will resend you the parts after you provide the corresponding photos.
2. Your item has been damaged in transit. For example, glass is broken or wicker is damaged.

We will resend you the parts after you provide the corresponding photos.

3. You receive the wrong box (es) due to a warehouse error.

Please provide the corresponding photos of the wrong SKU numbers on the outer box (es).

We will resend you the correct product or refund.

4. One or more boxes are lost in transit. We will resend you the correct product or refund.

5. If you want to return the item, please contact our customer service team first.

\*However, we still hope to work with you for a better solution instead of a return.

Please don't hesitate to contact our customer service team.

Customer will cover the return shipping fees if:

1. You don't like the product(s) after receiving the box (es).
2. You no longer need the product(s) but you have received the box (es).
3. You buy the product(s) by mistake but you have received the box (es).
4. Order/Shipment cancellation failed and you have received the box (es).
5. If you want other solutions, please contact our customer service team first.

---

## Return Request

In order to get a full refund as described in this return policy, all items must be:

(1) In a brand new/unused condition, please provide photos before and after packaging.

(2) When returning, all accessories and parts are firmly packed in all original packaging.

If your return does not meet the requirements, you may not get a full refund.

When will I be refunded?

The refund is released once the goods have been returned to our warehouse.

What if the product is damaged/defective outside of the valid return period?

We want you to be a happy customer.

Please reach out to us by email and we will come up with a solution to make sure you are satisfied.