

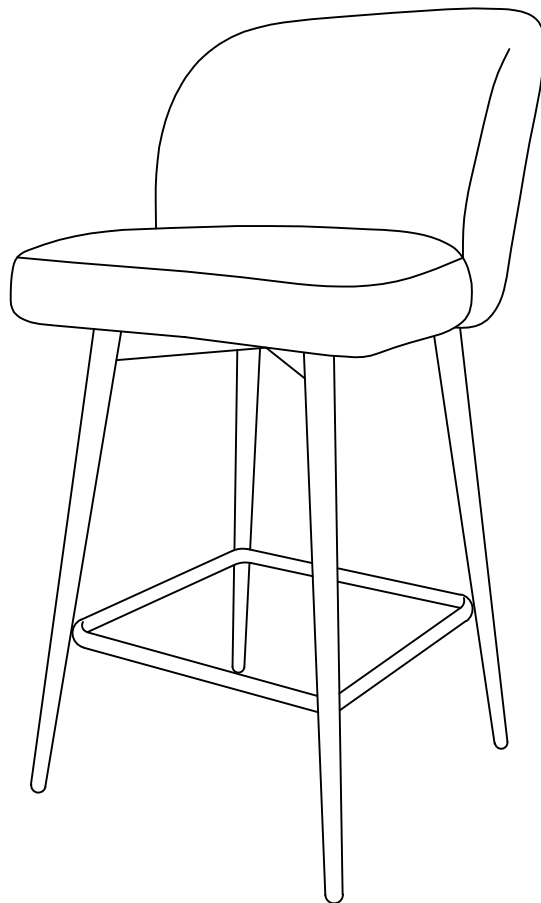

Assembly Manual

Counter & Bar Height Swivel Stool

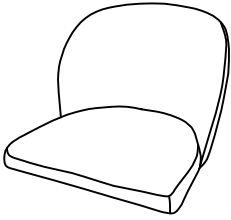
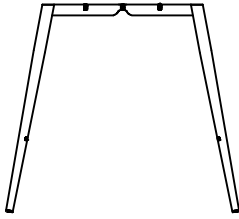
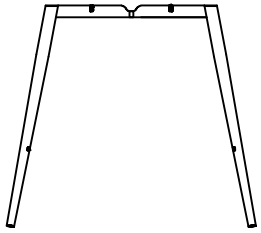
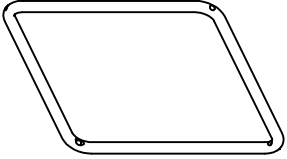
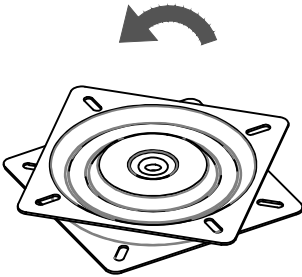
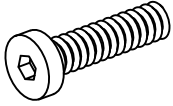
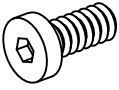

 **CAUTION**

THIS ASSEMBLY MANUAL CONTAINS IMPORTANT SAFETY INFORMATION.
PLEASE READ AND KEEP FOR FUTURE REFERENCE.

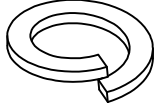
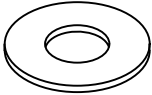
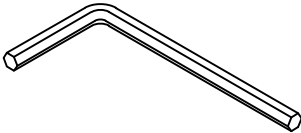
<p>Ax1</p> 	<p>Bx1</p> 	<p>Cx1</p> 
<p>Dx1</p> 	<p>Ex1</p> 	<p>Fx5</p>  <p>M6 x 30mm</p>
<p>Gx4</p>  <p>M6 x 20mm</p>	<p>Hx4</p>  <p>M6 x 25mm</p>	<p>Ix9</p>  <p>M6</p>
<p>Jx9</p>  <p>M6</p>	<p>Kx1</p>  <p>4#</p>	

Please read through the instructions below to familiarize yourself with the parts and steps before assembly.

Note: Do NOT use power tools for assembly.

ASSEMBLY INSTRUCTIONS

- ① Unpack and place seat (A), legs (B&C), foot rest (D) and swivel plate (E) on a clean surface.

Attach leg (B) to leg (C), using longest bolt (F), lock washer (I), flat washer (J) and allen wrench (K).

Note: Do not fully tighten yet.

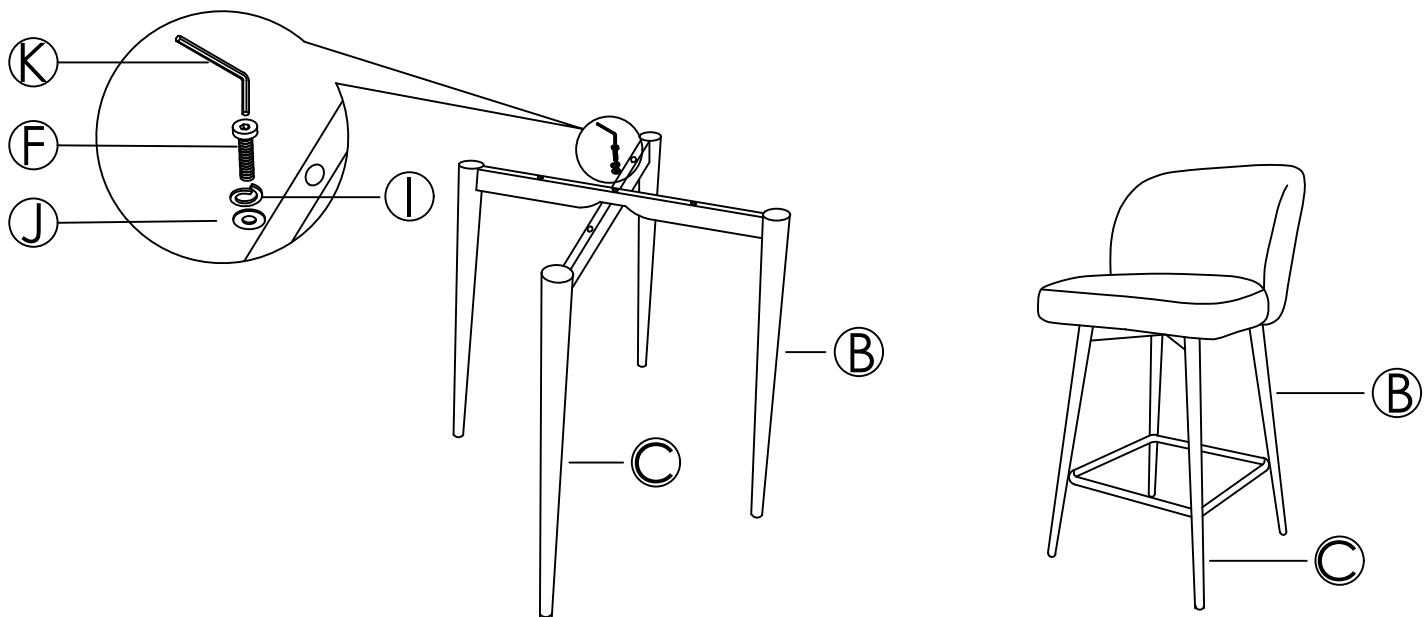

- ② **Loosely** attach the bolts (H) one by one and **keep them loose. Do not fully tighten.** After **loosely** attach the first bolt, move on to the diagonal bolt. After all 4 bolts are attached, use allen wrench (K) to tighten.

Note: Do NOT use power tools for assembly.

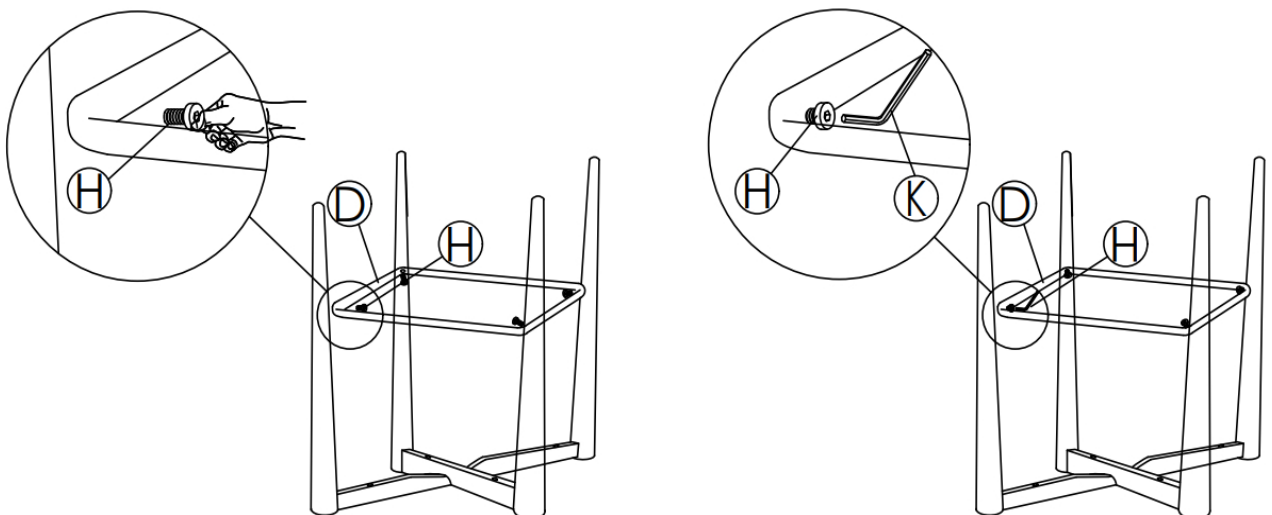

- ③ Fully tighten the longest bolt (F) in step 1 with allen wrench (K). Then attach swivel plate (E) to assembled legs in step 2, using longest bolts (F), lock washers (I), flat washers (J) and allen wrench (K). **Do not fully tighten yet.**

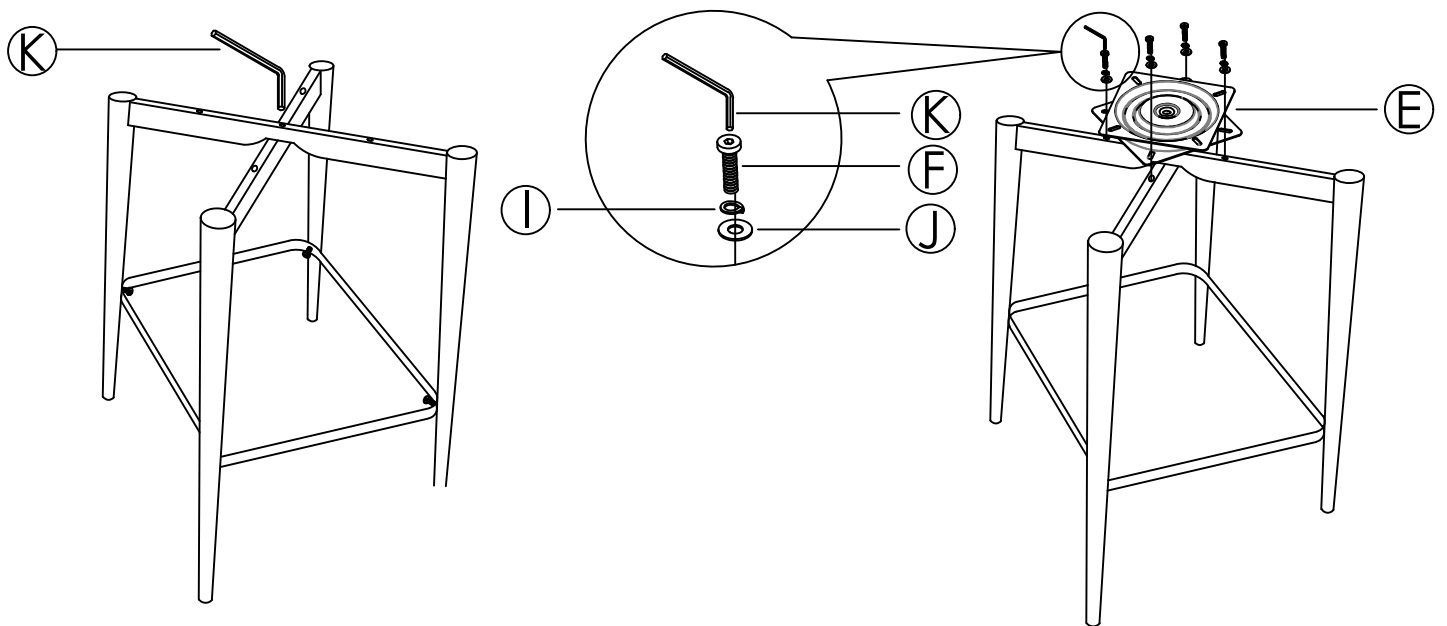

- ④ Put assembled legs in step 3 on a flat surface. Push legs up or down as necessary to level. Once level, tighten all bolts.

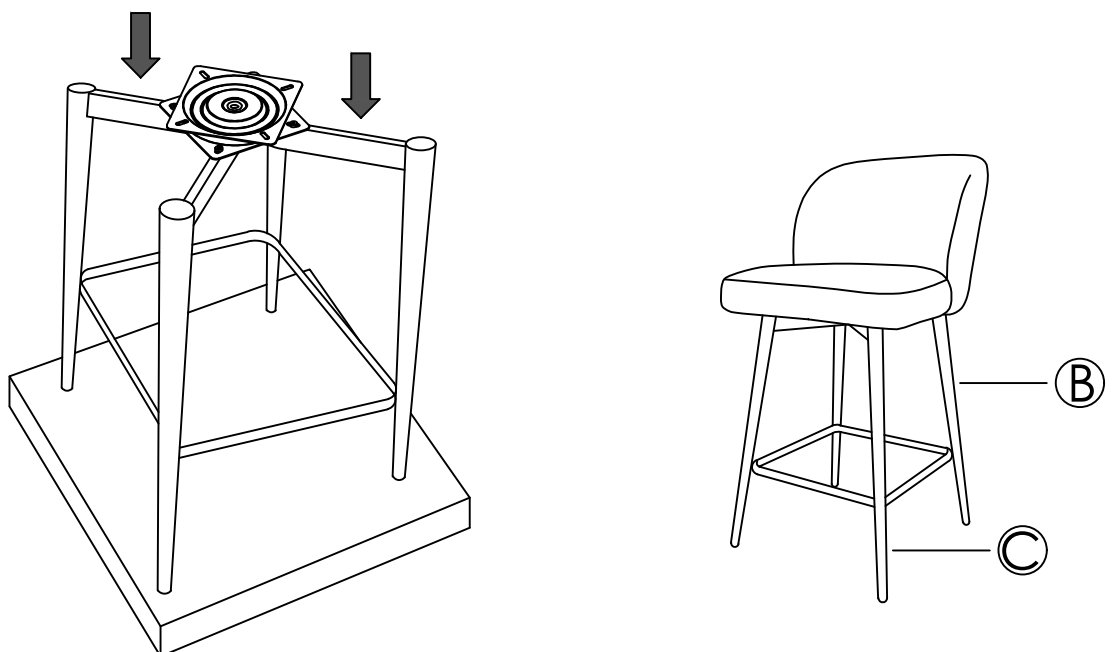

- ⑤ Turn assembled legs in step 3 upside down, and attach them to seat (A), using shortest bolts (G), lock washers(I), flat washers(J) and allen wrench(K).
Note: Tighten all bolts.

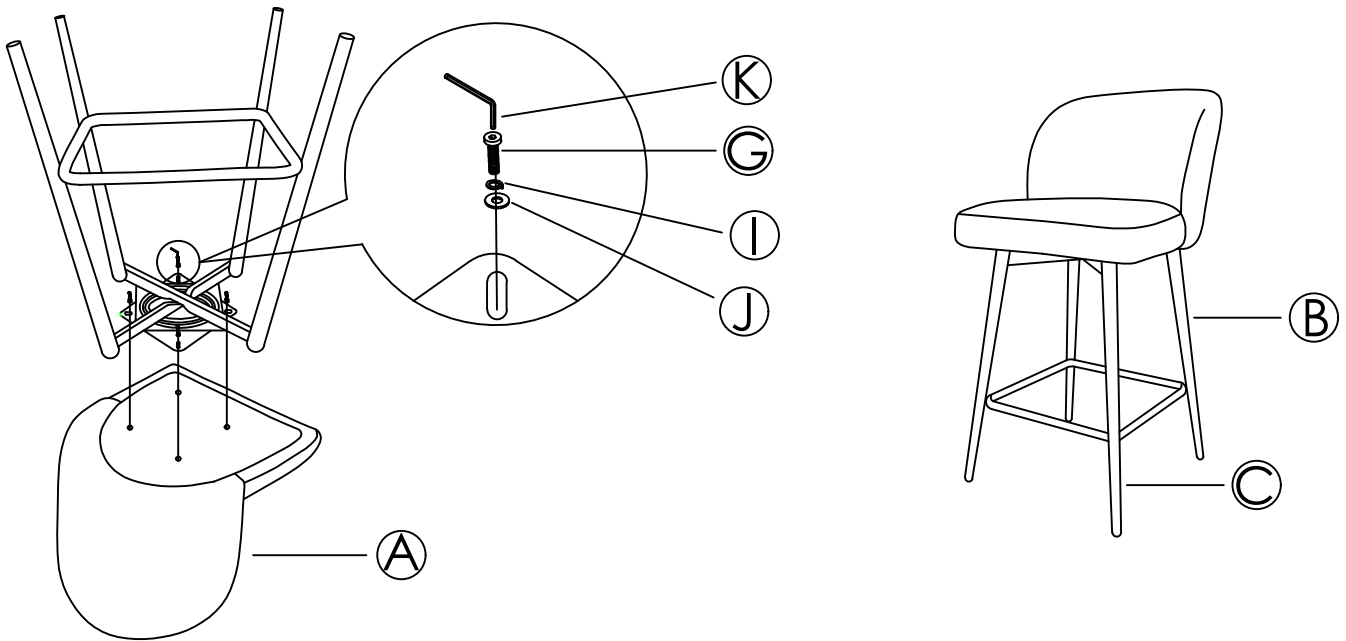

- ⑥ Turn assembled chair upright and place on a flat surface.
Note: Each leg has an adjustable foot leveler to help level your chair.

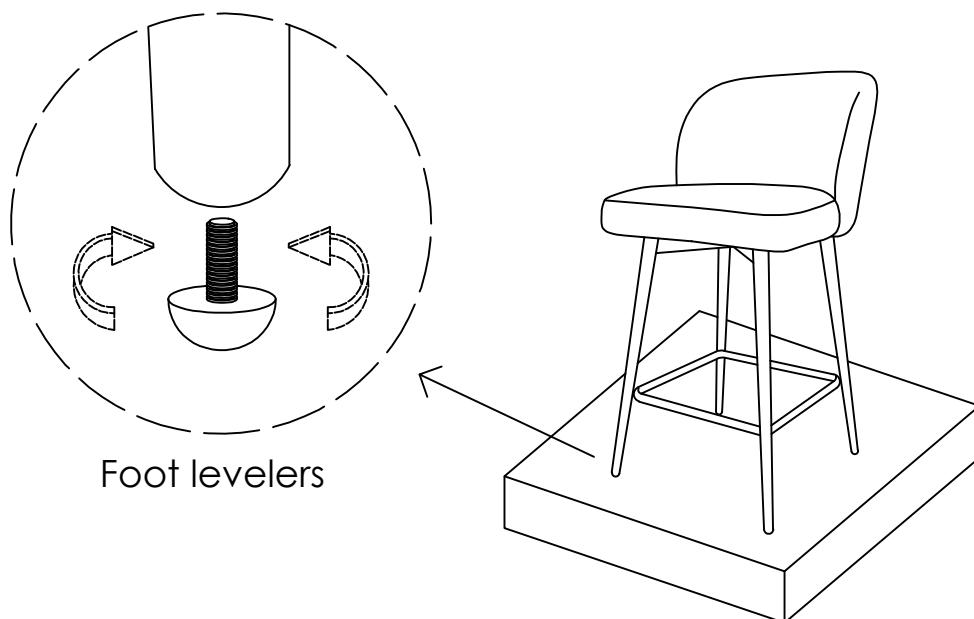

⑦ Assembly complete. Enjoy.

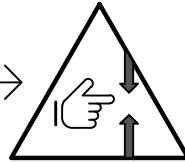
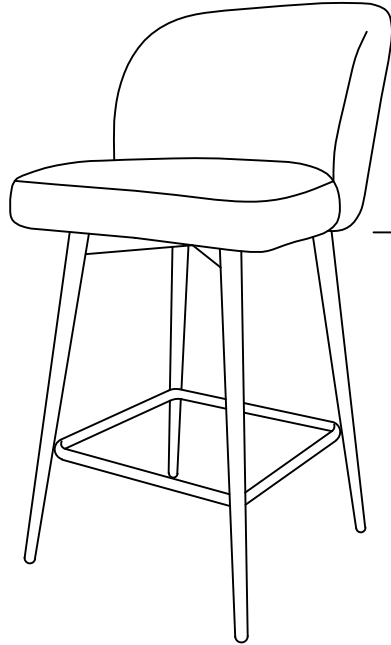

CAUTION: PINCH POINT.
Please keep hands clear during swivel.