

NOTICE

- * Please make sure that you have all parts indicated and they are in good condition before you begin assembly of this item. Refer to part list and hardware list below for guidance.
- * This item should be assembled on a soft surface to prevent scratching the finish during assembly.
- * This item may require periodic tightening.
- * If you are having difficulty, our friendly Customer Care team is always here to help. Please email customersupport@safavieh.com

PREPARATION

- * Before beginning assembly of product, make sure all parts are present. Compare parts with part contents list and hardware contents list.
- * If any part is missing or damaged, do not attempt to assemble the product.
- * Estimated Assembly Time: **45 minutes**.
- * Tools Required for Assembly (included): **Allen Key**

CARE AND MAINTENANCE

Store outdoor furniture indoors or cover well when not in use. Remove wooden furniture from standing water. Dust regularly with small brush or vacuum. Spills should be taken care of immediately before they harden or stain with a slightly dampened sponge. Do not use bleach solutions

 **SAFAVIEH**
O U T D O O R

Model# PAT7755

Product Dimensions







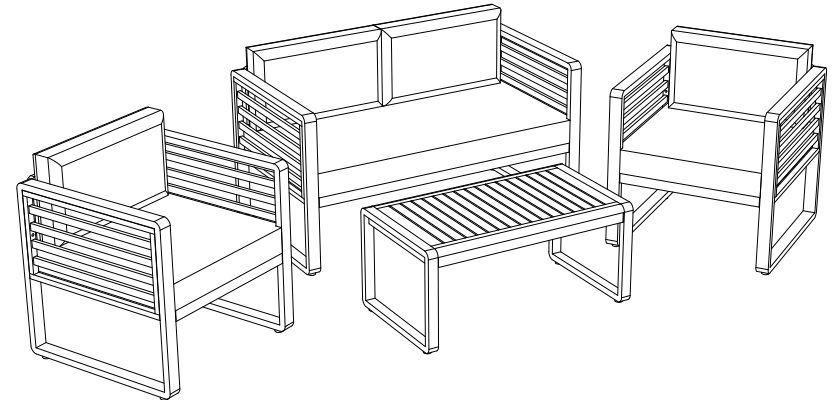



35.43"W x 19.69"D x 16.14"H (Table)





26.77"W x 25.98"D x 26.57"H (Chair)

49.60"W x 25.98"D x 26.57"H (Bench)



Part List and Hardware List

PIECE	DESCRIPTION	PICTURE	QUANTITY
A	Table Top		1X
B	Table Leg Frame		2X
C	Chair Seat Frame		2X
D	Chair Back Frame		2X
E	Bench Seat Frame		1X
F	Bench Back Frame		1X
G	Left Chair Leg		3X
H	Right Chair Leg		3X
CSH1	Back Cushion		4X
CSH2	Chair Seat Cushion		2X
CSH3	Bench Seat Cushion		1X

PIECE	DESCRIPTION	PICTURE	QUANTITY
HW1	Allen Bolt: M6 x 0.5 x 20 mm		8X
HW2	Allen Bolt: M6 x 0.5 x 35 mm		38X
HW3	Flat washer: M6 x 1 mm		46X
HW4	Allen Key		2X
HW5	Plastic cover		12X



Weight Capacity : 176 lbs (Table)
: 352 lbs (Chair)
: 704 lbs (Bench)

Warning : Do not stand on Table/Chair/Bench
Warning : Do not over torque bolts/screws

PREPARATION

- * Before beginning assembly of product, make sure all parts are present. Compare parts with part contents list and hardware contents list.
- * If any part is missing or damaged, do not attempt to assemble the product.
- * Estimated Assembly Time: **45 minutes.**
- * Tools Required for Assembly (included): **Allen Key**
- * If you are having difficulty, our friendly Customer Care team is always here to help. Please email customersupport@safavieh.com

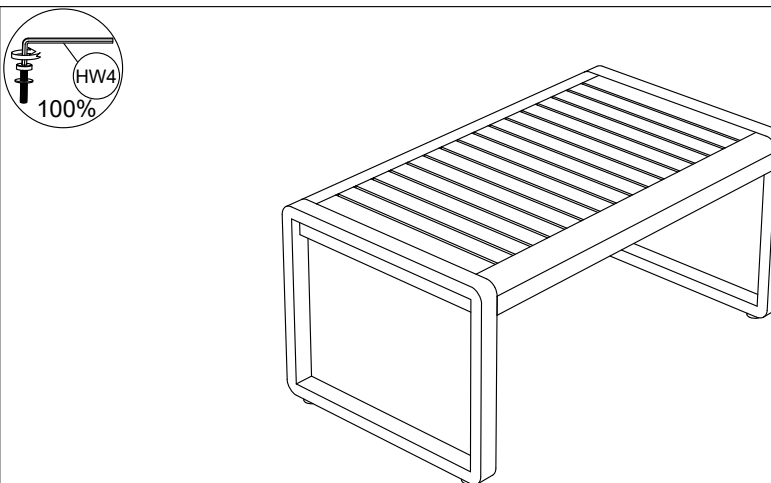
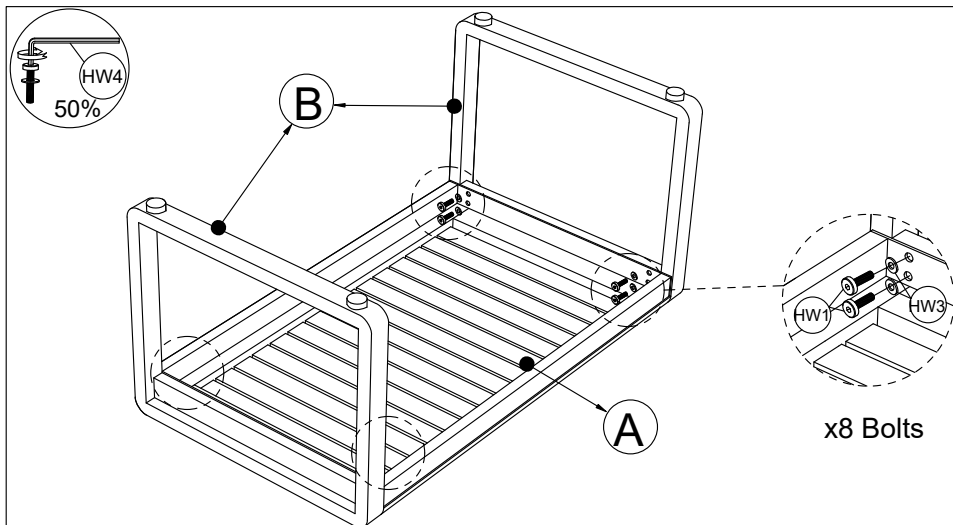

STEP 1: Connect Table Leg (B) & Table Top (A), tighten Bolt (HW1) & Flat washer (HW3) with Allen Key (HW4).

STEP 2: Put The table upright, then firmly tighten Bolts with Allen Key (HW4) to finish Table.

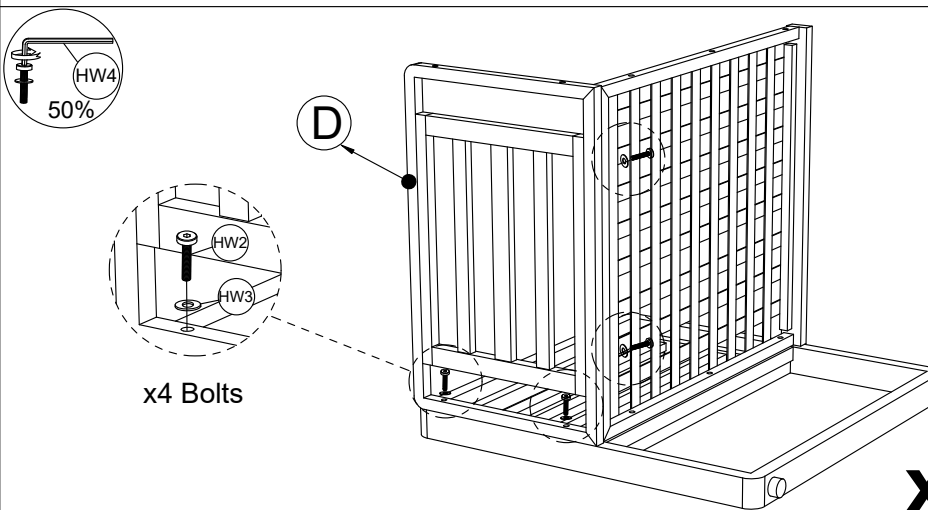
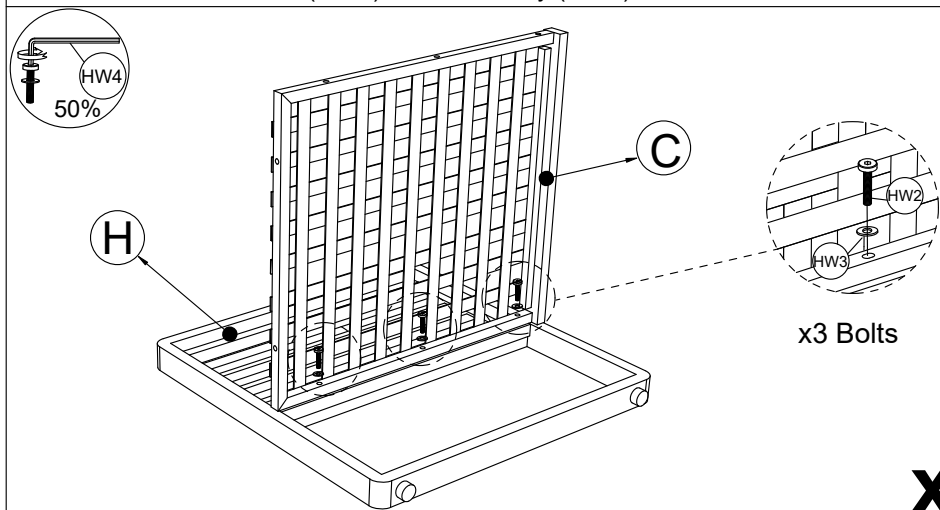

STEP 3: Connect Chair Seat Frame (C) & Right Chair Leg (H), tighten Bolt (HW2) Flat Washer (HW3) with Allen Key (HW4).

STEP 4: Connect The Part from Step 3 & Chair Back Frame (D), tighten Bolt (HW2) Flat Washer (HW3) with Allen Key (HW4).

PREPARATION

- * Before beginning assembly of product, make sure all parts are present. Compare parts with part contents list and hardware contents list.
- * If any part is missing or damaged, do not attempt to assemble the product.
- * Estimated Assembly Time: **45 minutes.**
- * Tools Required for Assembly (included): **Allen Key**
- * If you are having difficulty, our friendly Customer Care team is always here to help. Please email customersupport@safavieh.com

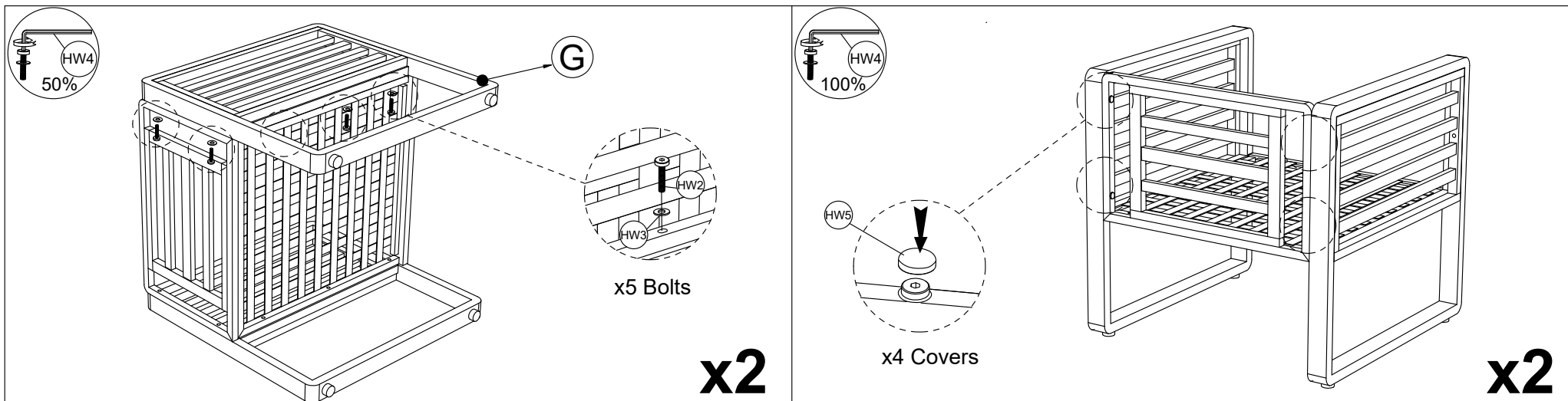

STEP 5: Connect The Part from Step 4 & Left Chair Leg (G), tighten Bolt (HW2) Flat Washer (HW3) with Allen Key (HW4).

STEP 6: Put the Chair upright, firmly tighten Bolts with Allen Key (HW4), Push Plastic Covers (HW5)

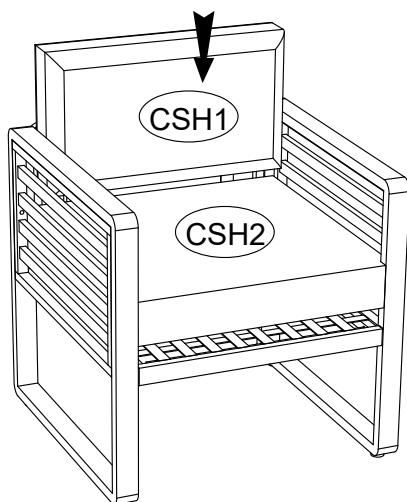

STEP 7: Set up the Cushions (CSH1)+(CSH2) to finish Chair.

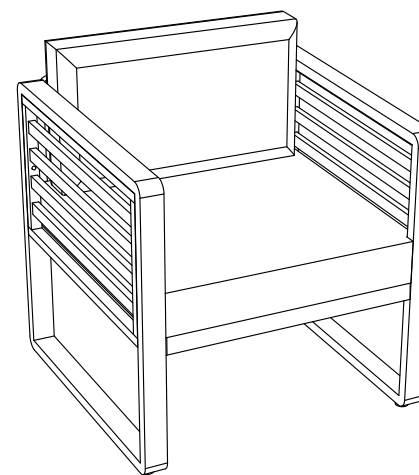

STEP 8: Finish Chair

PREPARATION

- * Before beginning assembly of product, make sure all parts are present. Compare parts with part contents list and hardware contents list.
- * If any part is missing or damaged, do not attempt to assemble the product.
- * Estimated Assembly Time: **45 minutes.**
- * Tools Required for Assembly (included): **Allen Key**
- * If you are having difficulty, our friendly Customer Care team is always here to help. Please email customersupport@safavieh.com

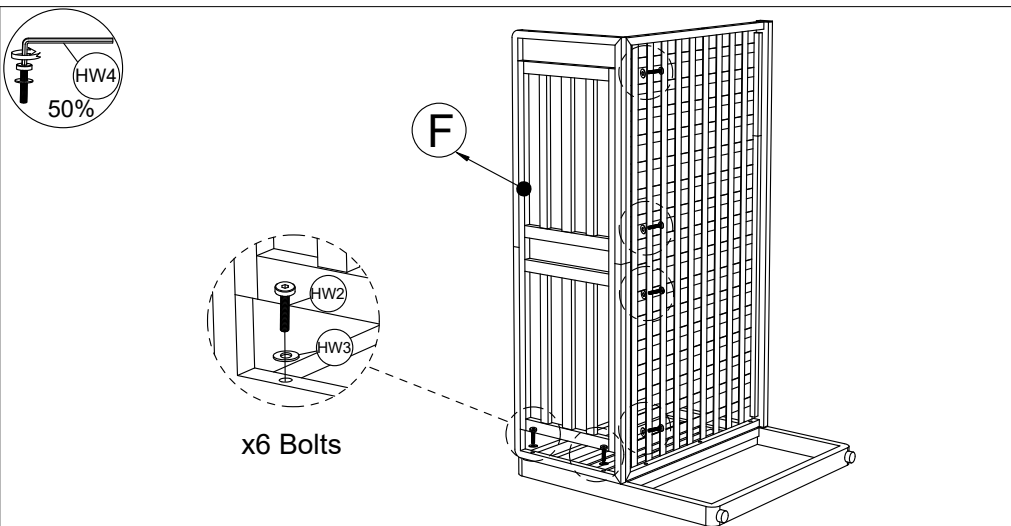
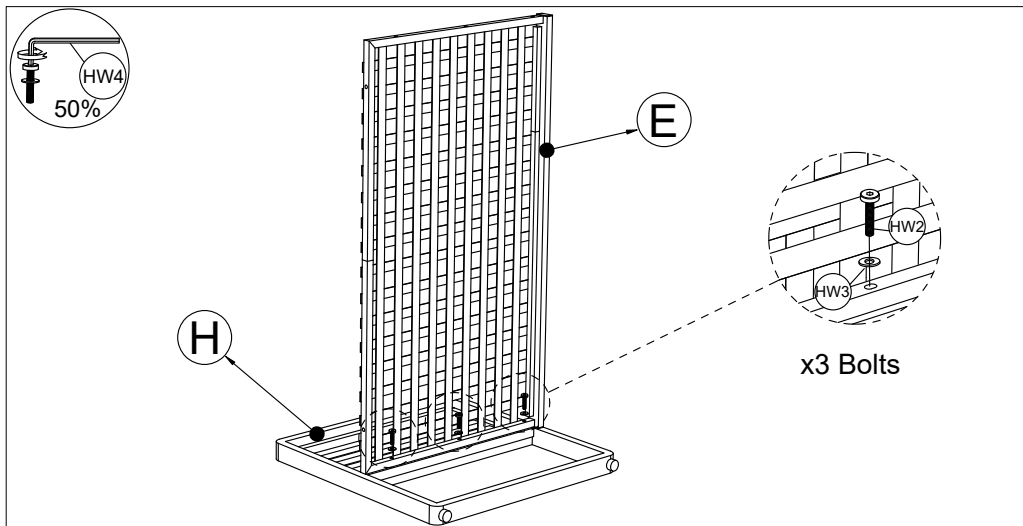

STEP 9: Connect Bench Seat Frame (E) & Right Chair Leg (H), tighten Bolt (HW2) Flat Washer (HW3) with Allen Key (HW4).

STEP 10: Connect The Part from Step 9 & Bench Back Frame (F), tighten Bolt (HW2) Flat Washer (HW3) with Allen Key (HW4).

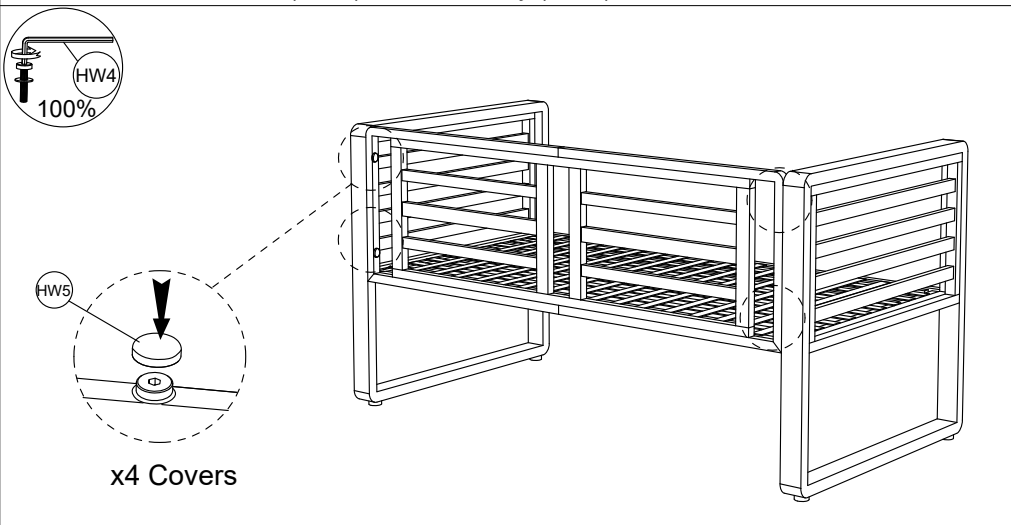
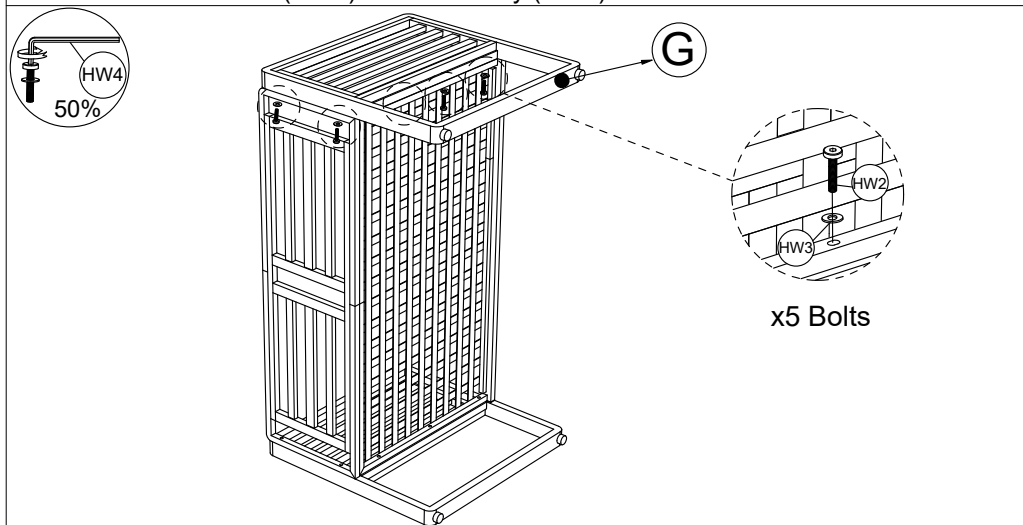

STEP 11: Connect The Part from Step 10 & Left Chair Leg (G), tighten Bolt (HW2) Flat Washer (HW3) with Allen Key (HW4).

STEP 12: Put the Bench upright, firmly tighten Bolts with Allen Key (HW4), Push Plastic Covers (HW5)

PREPARATION

- * Before beginning assembly of product, make sure all parts are present. Compare parts with part contents list and hardware contents list.
- * If any part is missing or damaged, do not attempt to assemble the product.
- * Estimated Assembly Time: **45 minutes.**
- * Tools Required for Assembly (included): **Allen Key**
- * If you are having difficulty, our friendly Customer Care team is always here to help. Please email customersupport@safavieh.com

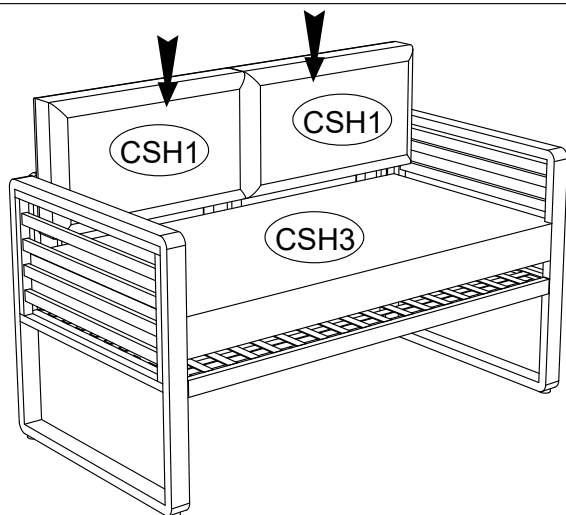

STEP 13: Set up the Cushions (CSH1)+(CSH3) to finish Bench.

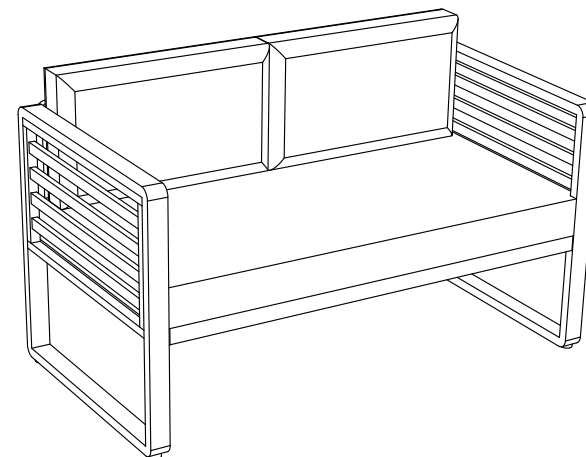

STEP 14: Finish Bench

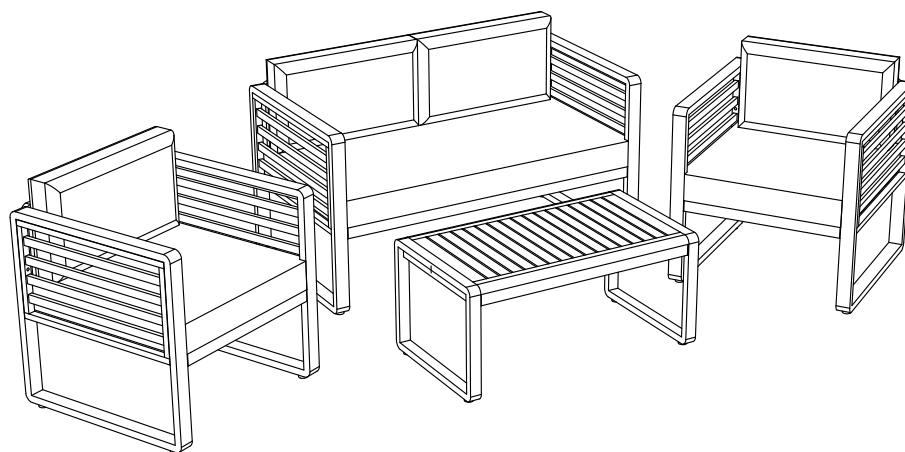

STEP 15: Finish The Sofa.