

ASSEMBLY INSTRUCTIONS

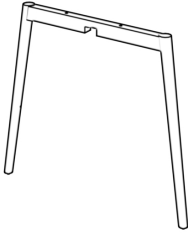

BAR STOOL

SPARE PARTS



Ax1

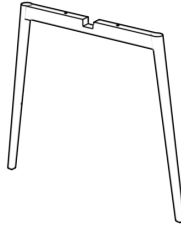

Bx1

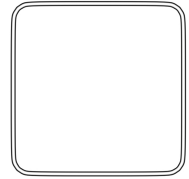

Cx1

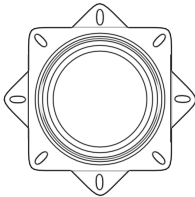

Dx1

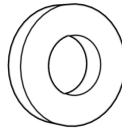

Ex2

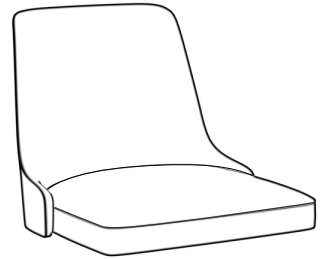

Fx1

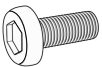

Gx6+1extra
(M6*16mm)

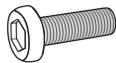

Hx2+1extra
(M6*20mm)

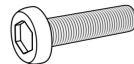

Ix4+1extra
(M6*30mm)



Jx1

1

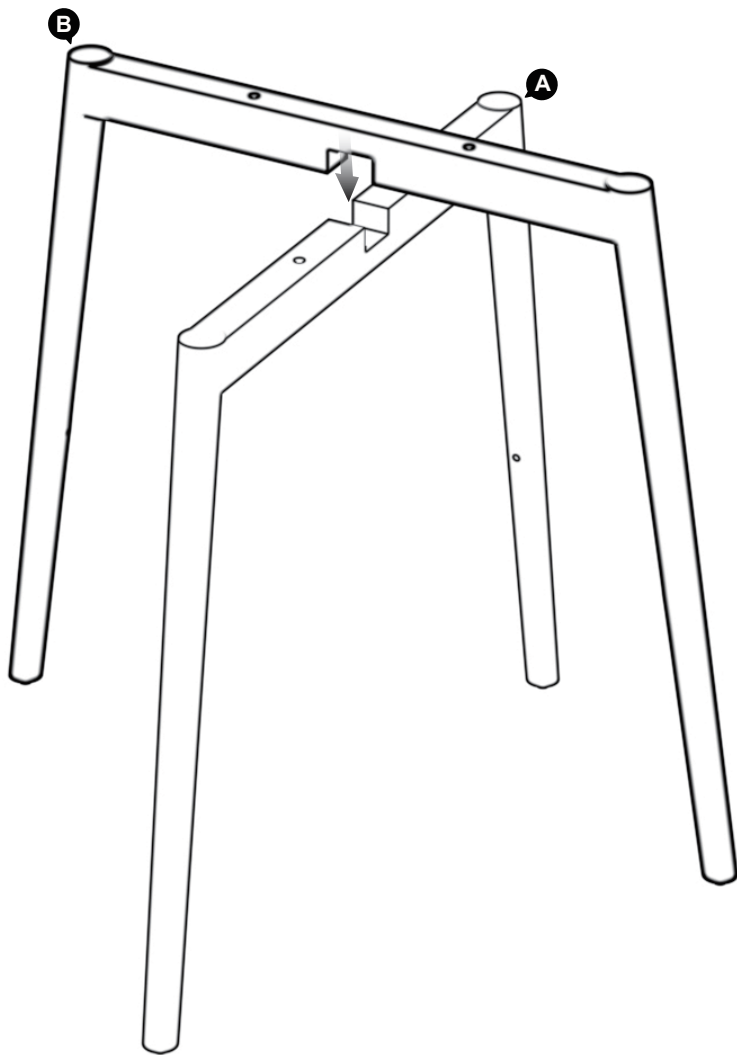

2

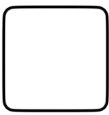

Cx1

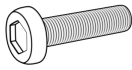

I x4

Install the 4 screws **I** to **50%** in sequence.
After all the four screws are installed, tighten them to **100%**

Note: When installing Accessory **C**
make sure the drain hole is facing up

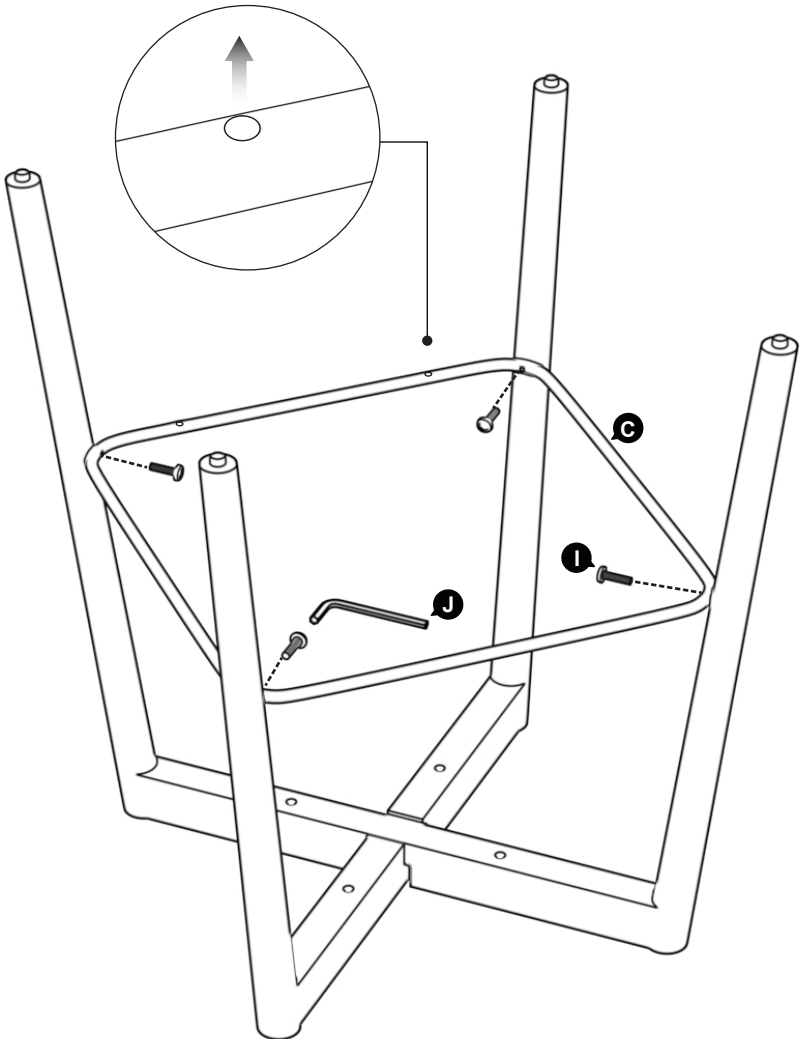

3



Dx1

Note: When installing the turntable, please rotate the turntable 45 degrees

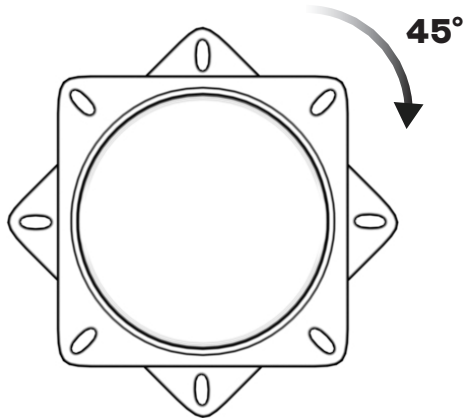
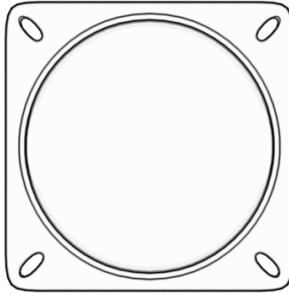

4

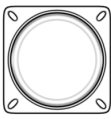

Dx1

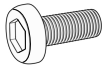

Gx4

Install the 4 screws **G** to **50%** in sequence.
After all the four screws are installed, tighten them to **100%**

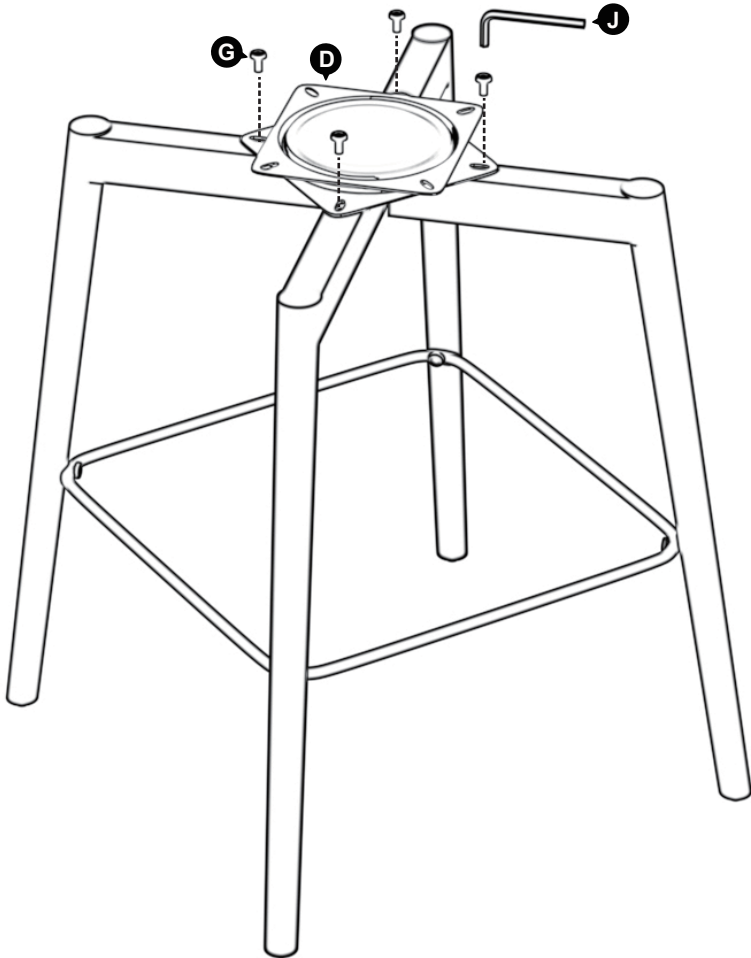

5

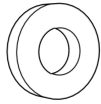

Ex2

Note: Accessories E should be placed at the front end, not at the back end

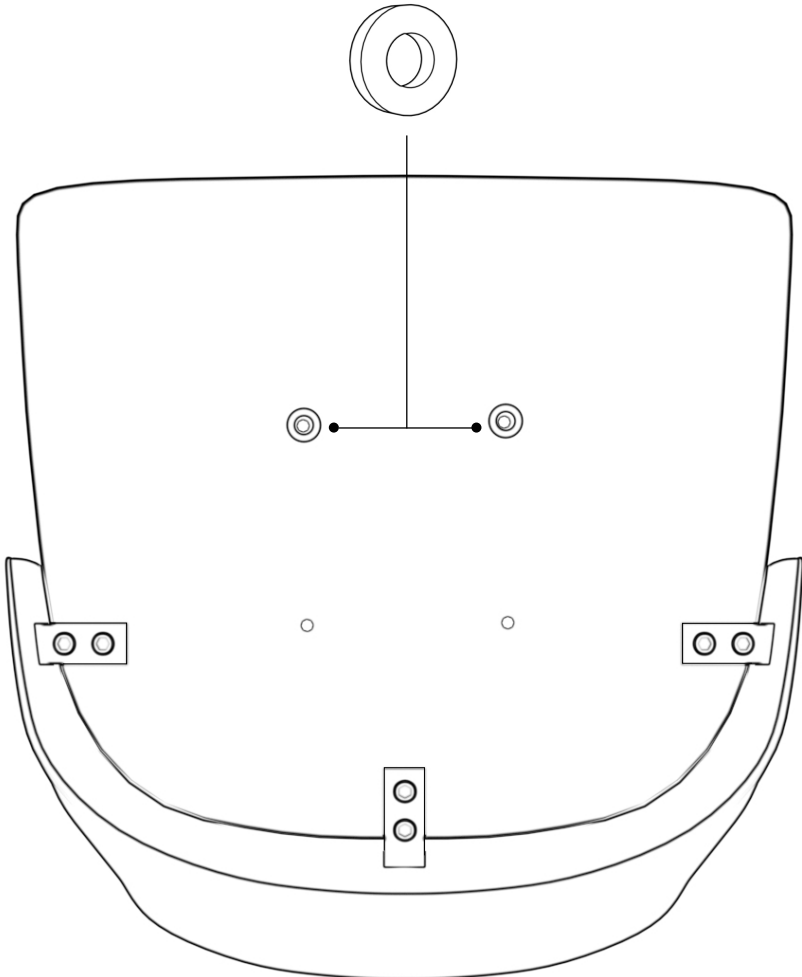

6



Fx1



Ex2

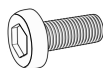

Gx2

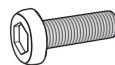

Hx2

Install screws **G** and **H** to **50%**
After screws are installed, tighten them to **100%**

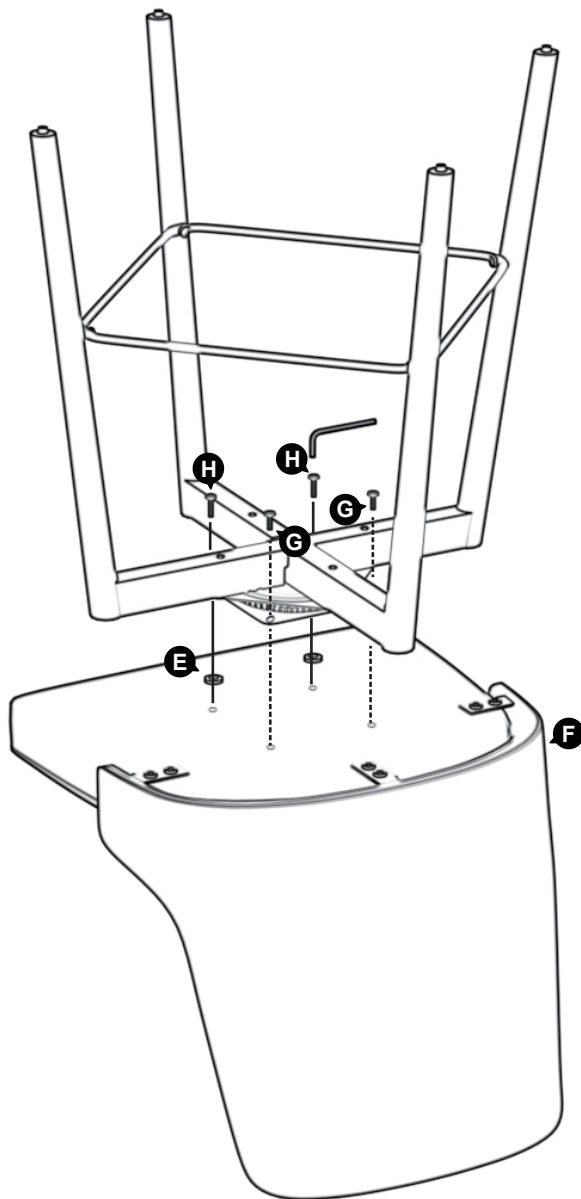

If you feel that the chair is not balance you can adjust the foot nails to level according to your needs

