

Assembly Instructions

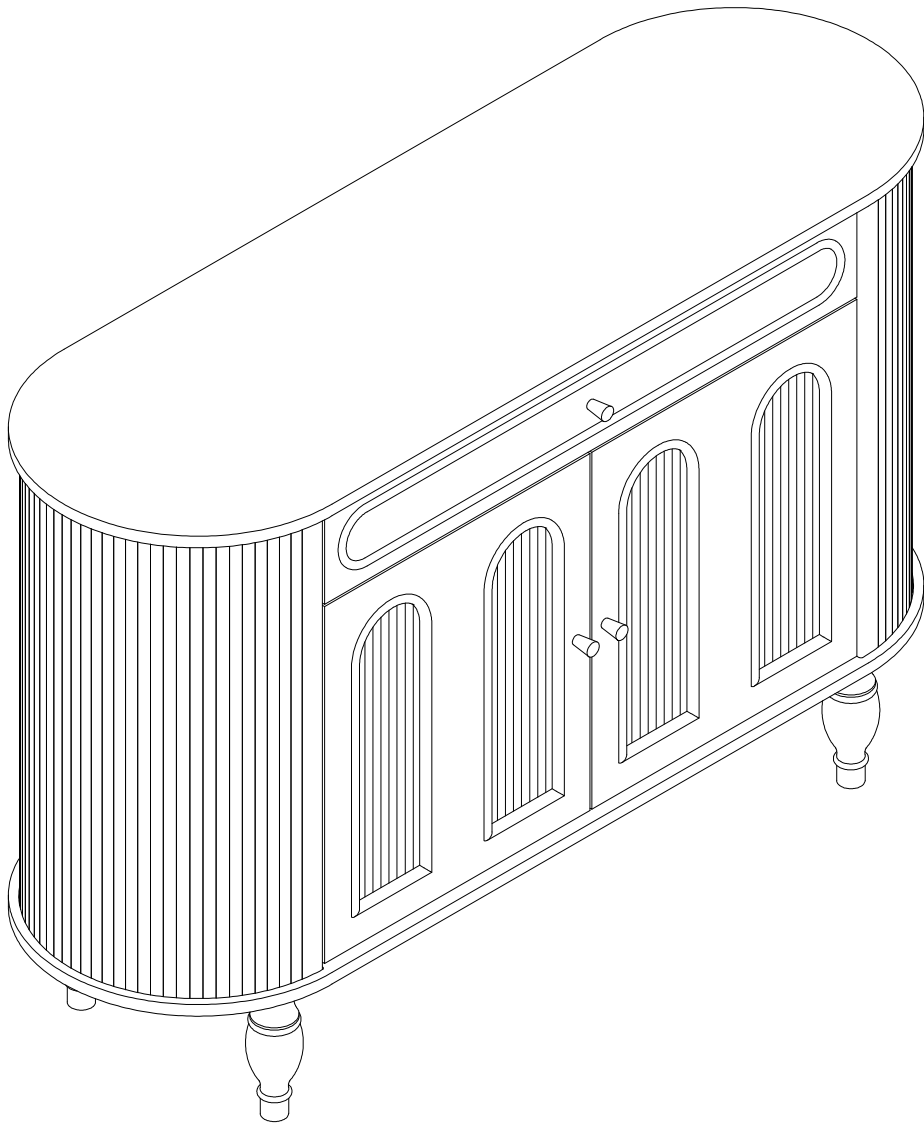

Before Assembly

Tips Before Your Start:

- Remove all wrapping material, including staples & packing straps before you start to assemble.
- DO NOT tighten all screws and bolts until the assembly is completely assembled.
- Keep all hardware parts out of reach of children.

QUICKFIT

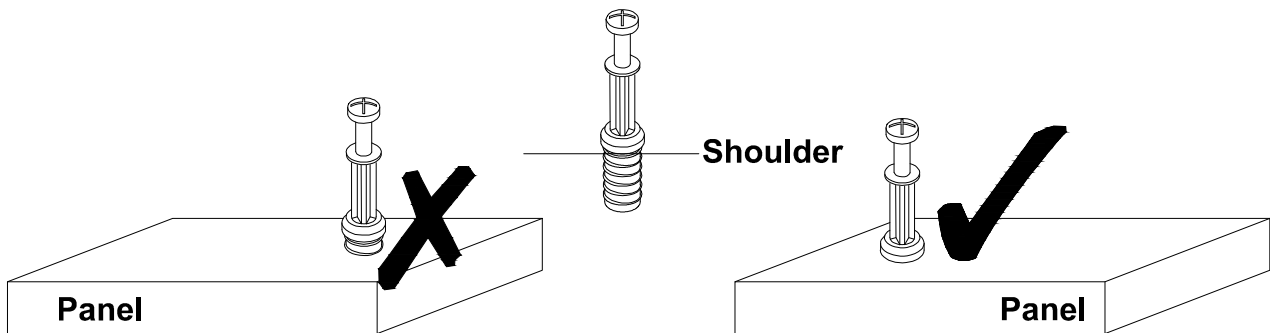

Tighten quickfit until shoulder is flush with panel. Do not overtighten or undertighten.

CAM LOCK

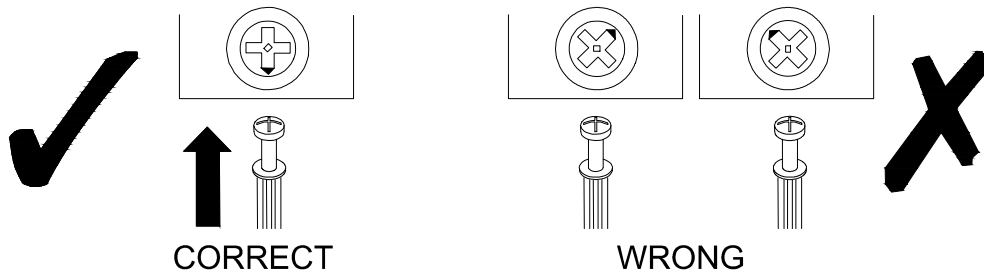

When fitting a cam lock, ensure the starting position is correct before inserting the connecting QUI CKFIT

Quickfit head should be in the centre of the cam lock when the two panels are joined.

Cam lock should be inserted before quickfit.

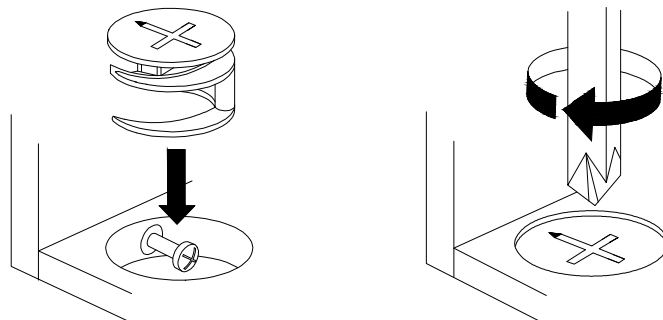

Turn cam lock clockwise to tighten.

Before Assembly

Tips Before Your Start

How to separate the drawer slider:

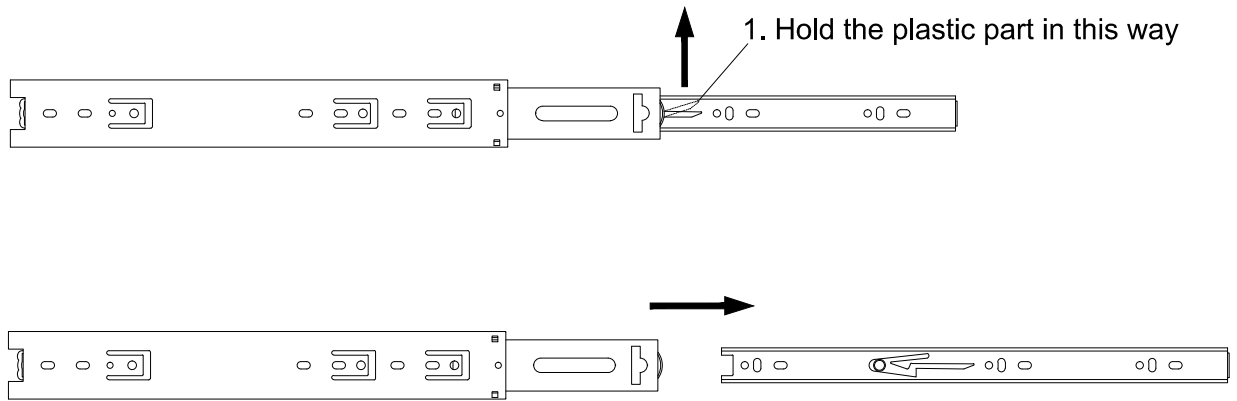

2. Pull out the inner slider for drawer box fixing

Drawer Front Alignment

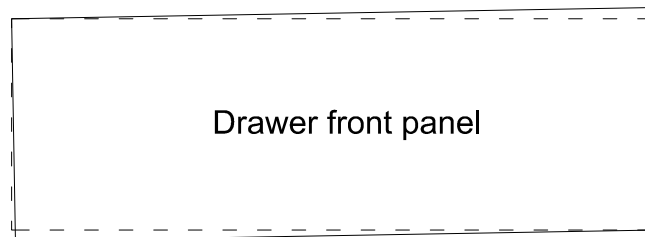



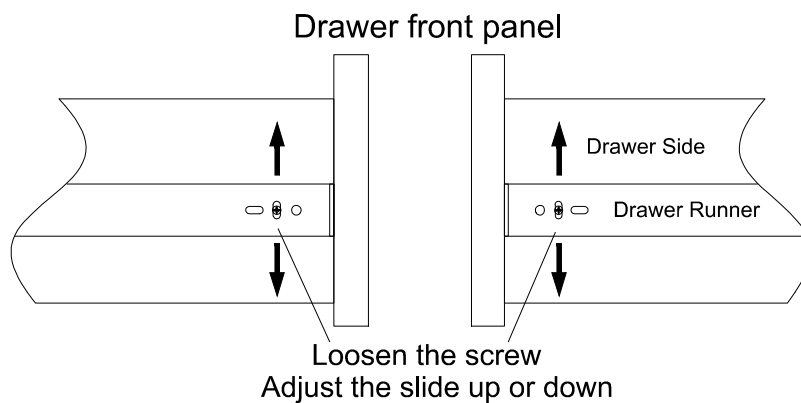





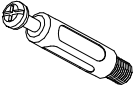

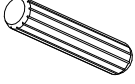
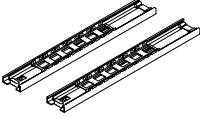



If the drawer front panel is NOT level after being assembled, then...

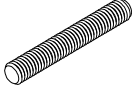

Loosen the screws on the left and right hand side, then adjust the drawer slide up or down, until the drawer fronts are even/level, then tighten the screws.

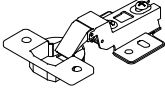
Part List

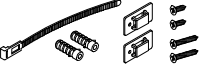
<p>No. A Quantity:28 Pcs Cam Lock Dowel 8*28mm</p> 	<p>No. B Quantity:28 Pcs Cam Ø15</p> 	<p>No. C Quantity:28 Pcs Sticker Ø20</p> 	<p>No. D Quantity:8 Pcs Dowel 8*30mm</p> 
<p>No. E Quantity:1 Sets Drawer Slider 10"</p> 	<p>No. F Quantity:4 Pcs Screw M4*30mm</p> 	<p>No. G Quantity:32 Pcs Screw M3.5*14mm</p> 	<p>No. H Quantity:3 Pcs Handle Ø20*23mm</p> 
<p>No. I Quantity:4 Pcs Foot Pad Ø20</p> 	<p>No. J Quantity:2 Pcs Screw M6*35mm</p> 	<p>No. K Quantity:2 Pcs Screw M6*55mm</p> 	<p>No. L Quantity:2 Pcs Screw M6*35mm</p> 
<p>No. M Quantity:4 Pcs Screw M6*40mm</p> 	<p>No. N Quantity:1 Pcs Allen Key 4#</p> 	<p>No. O Quantity:3 Pcs Screw M4*20mm</p> 	<p>No. P Quantity:4 Pcs Hinge</p> 
<p>No. Q Quantity:8 Sets Plastic Wedge</p> 	<p>No. R Quantity:1 Sets Anti-falling Parts</p> 		

Product structure

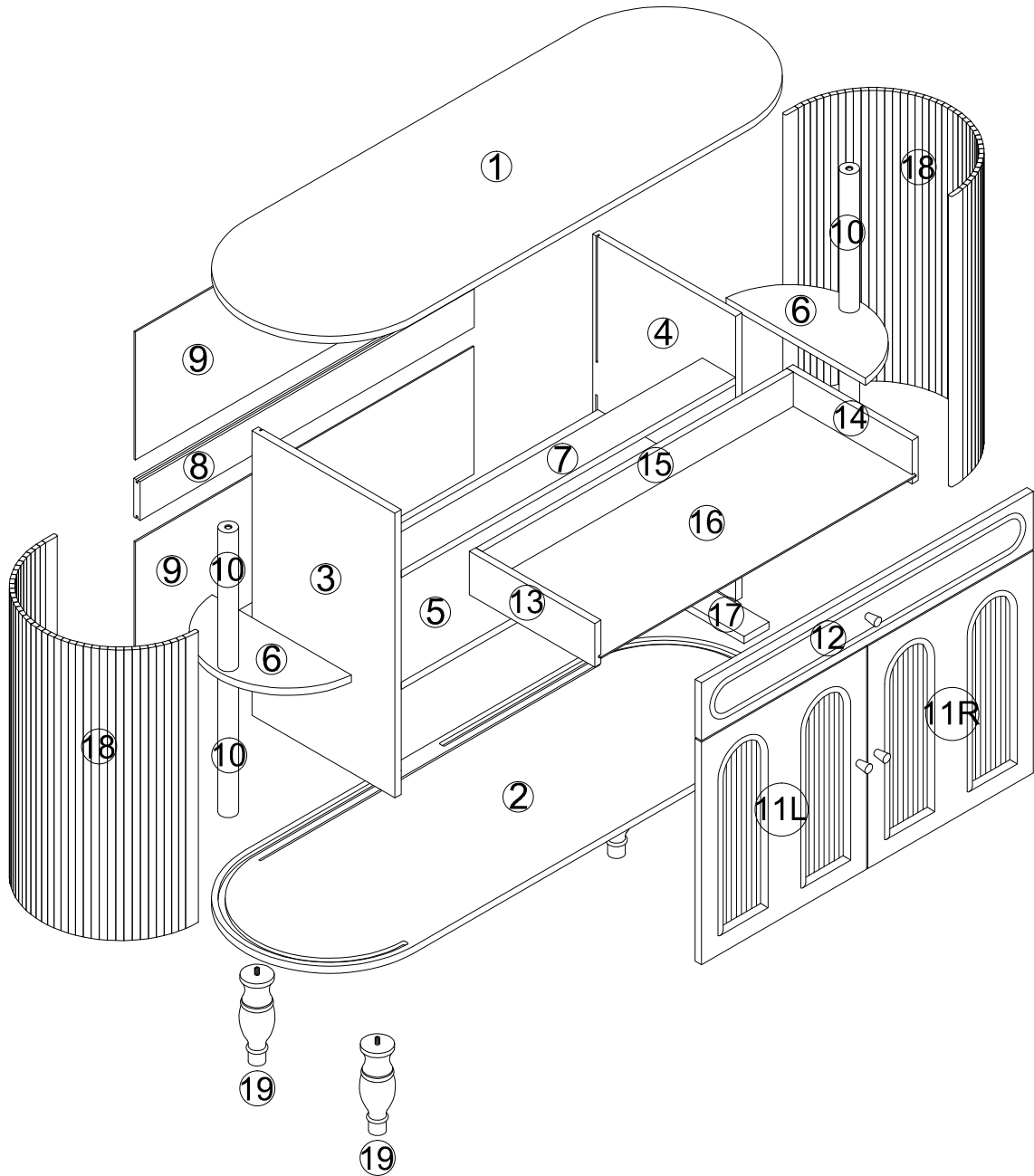

STEP 1



The first screw hole should corresponded with the board location hole

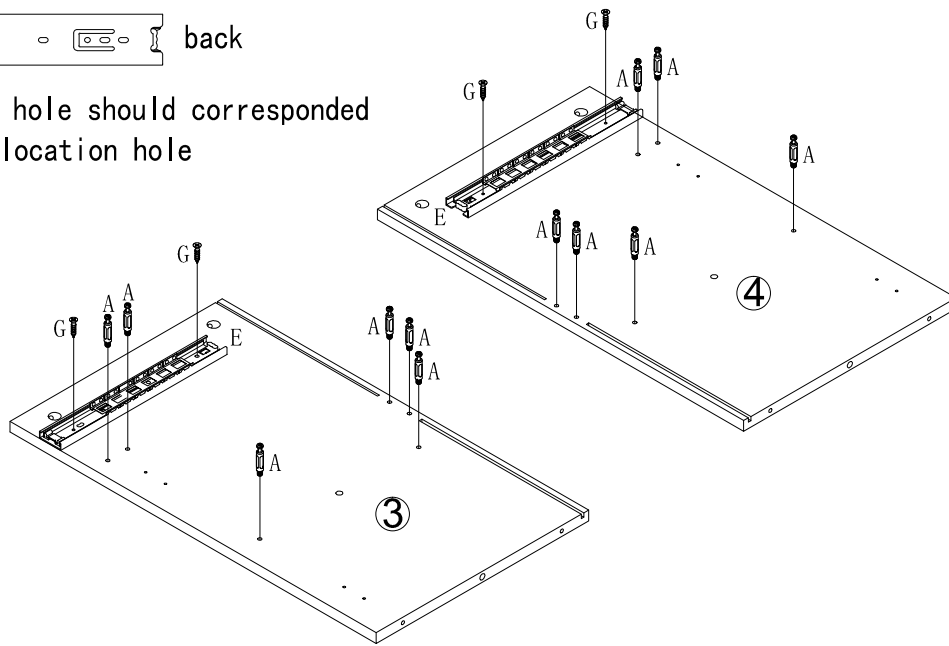

No. A
Quantity: 12 Pcs
8*28 mm



No. E
Quantity: 1 Sets
10"

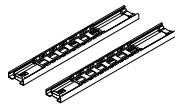

No. G
Quantity: 4 Pcs
M3.5*14mm



STEP 2

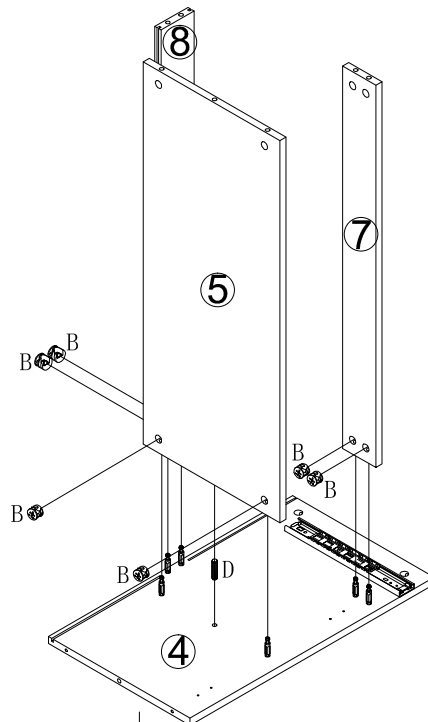

No. B
Quantity: 6 Pcs
Ø15



No. D
Quantity: 1 Pcs
8*30mm

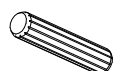

STEP 3

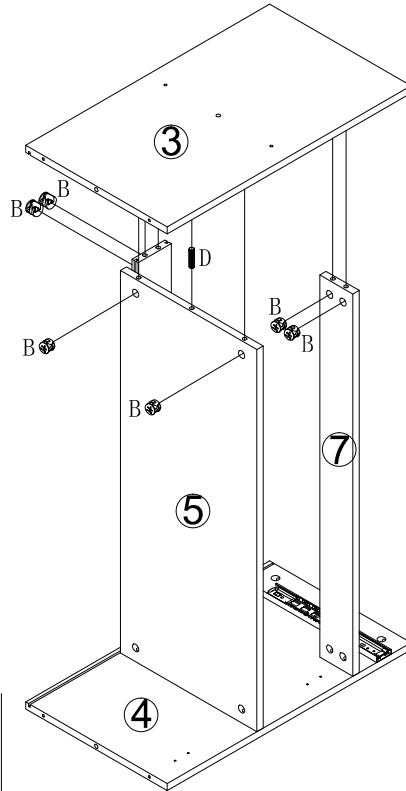

No. B
Quantity: 6 Pcs
Ø15



No. D
Quantity: 1 Pcs
8*30mm

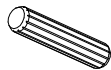

STEP 4

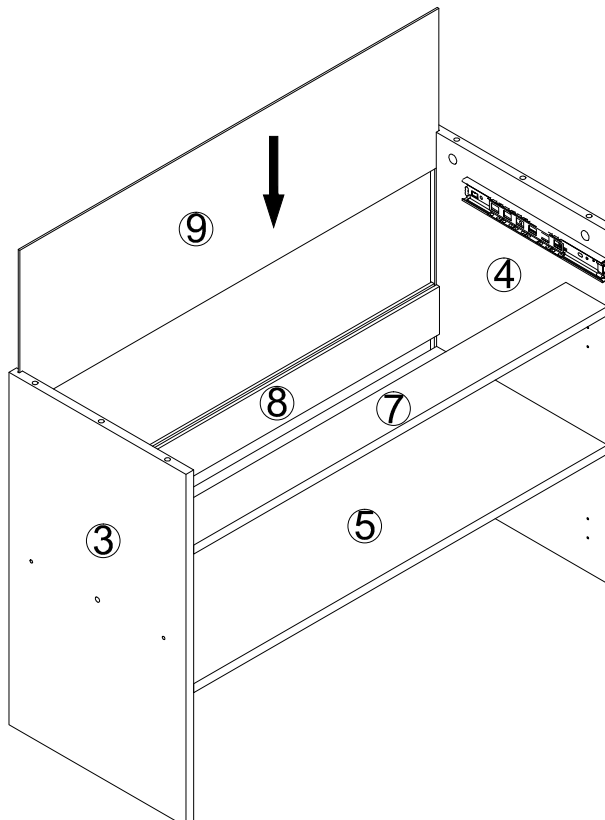

STEP 5

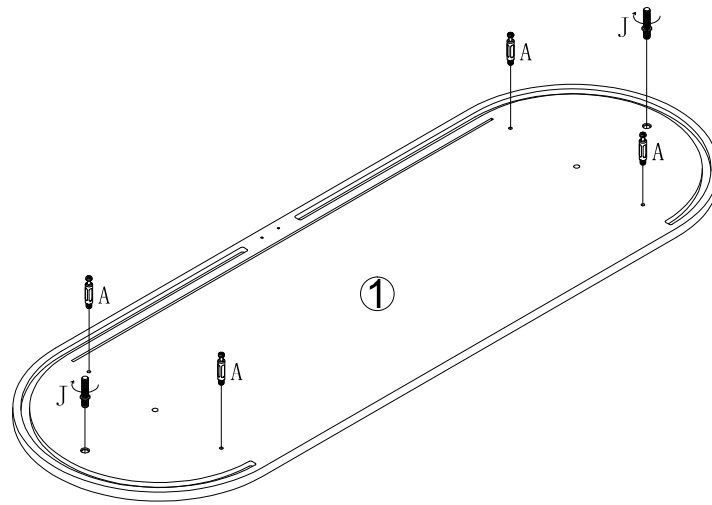

No. A
Quantity: 4 Pcs
8*28 mm



No. J
Quantity: 2 Pcs
M6*35mm



STEP 6

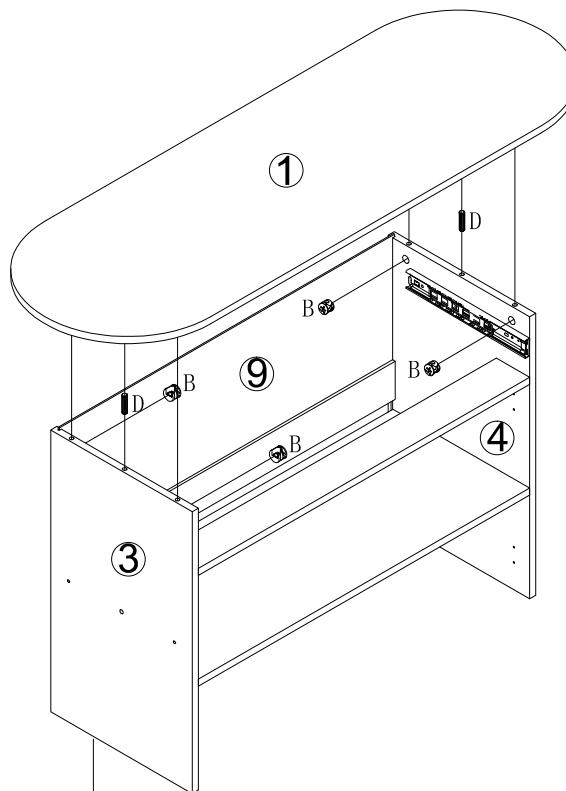

No. B
Quantity: 4 Pcs
Ø15



No. D
Quantity: 2 Pcs
8*30mm

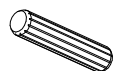

STEP 7

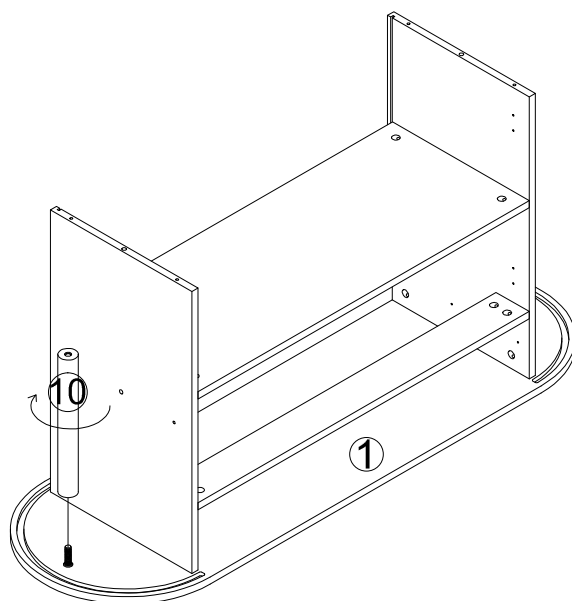

STEP 8

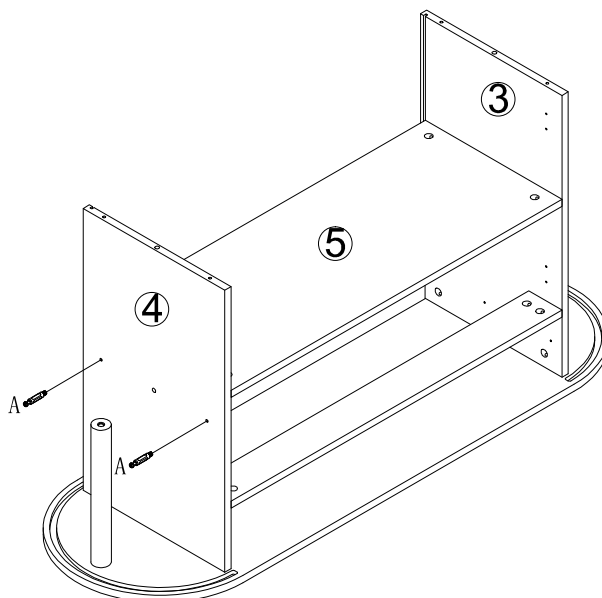

No. A
Quantity: 2 Pcs
8*28 mm



STEP 9

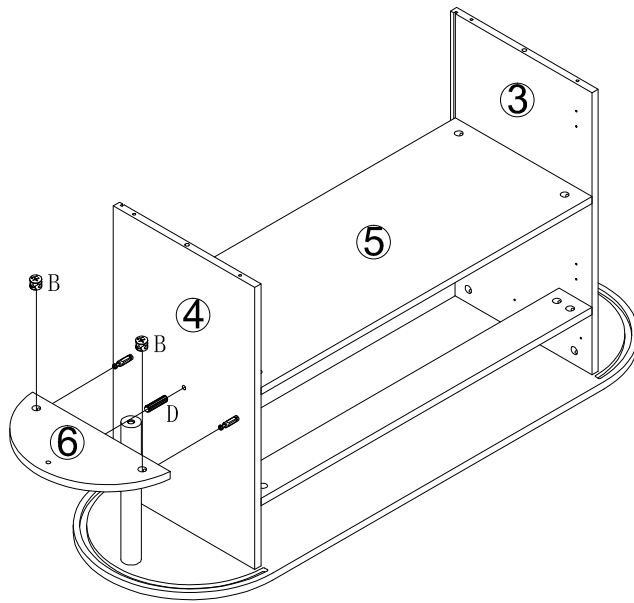

No. B
Quantity: 2 Pcs
Ø15



No. D
Quantity: 1 Pcs
8*30mm

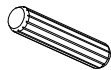

STEP 10

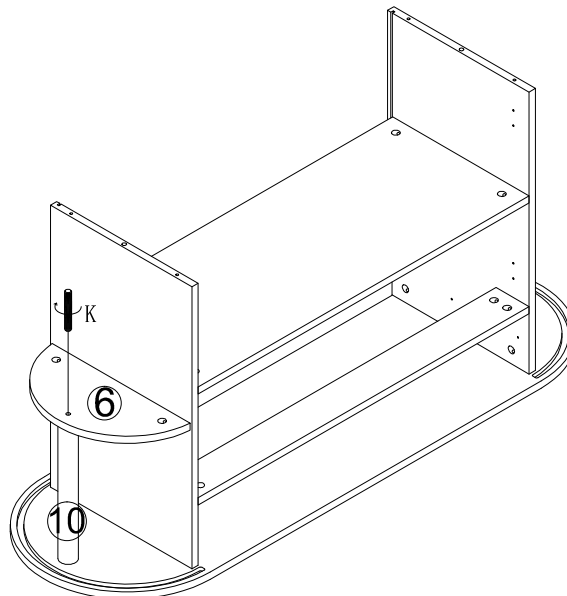

No. K
Quantity: 1 Pcs
M6*55mm

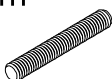

STEP 11

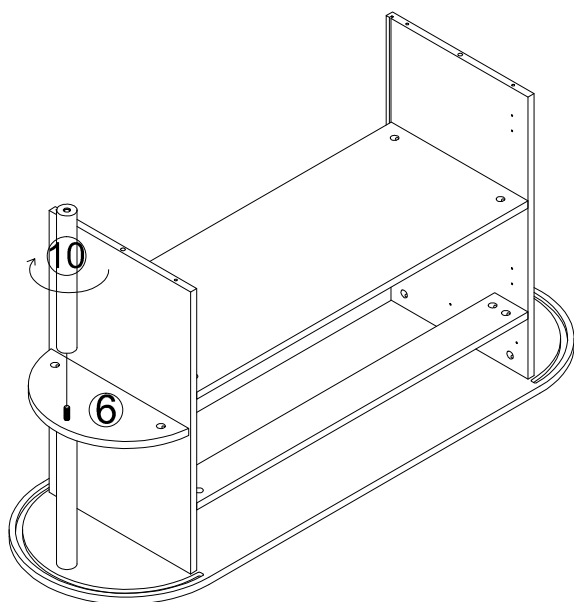

STEP 12

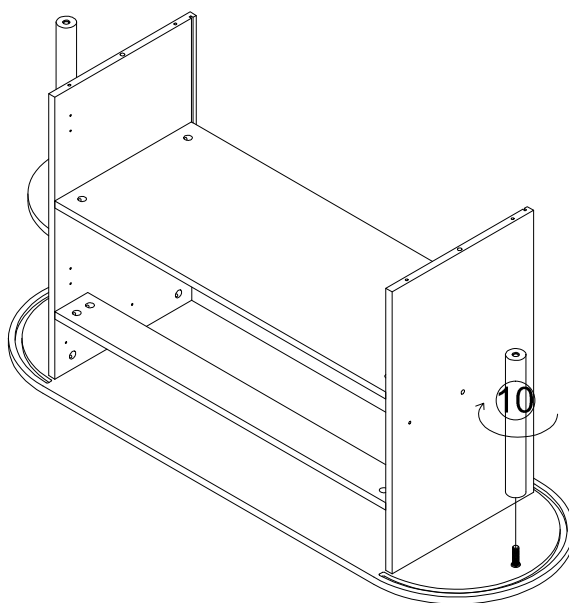

STEP 13

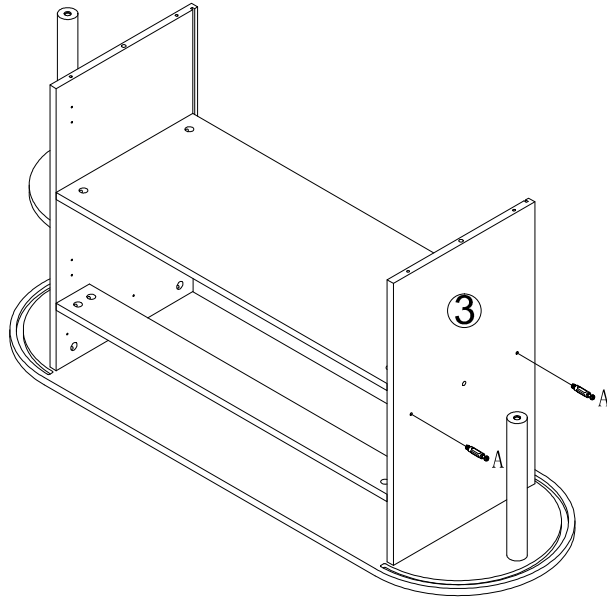

No. A
Quantity: 2 Pcs
8*28 mm



STEP 14

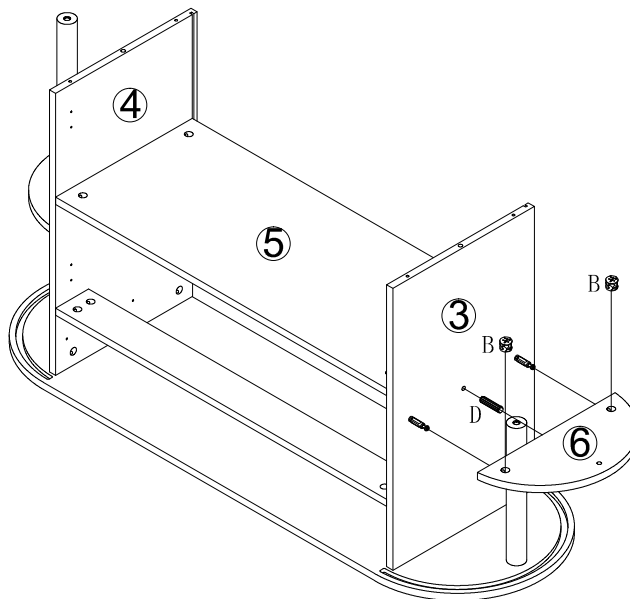

No. B
Quantity: 2 Pcs
Ø15



No. D
Quantity: 1 Pcs
8*30mm

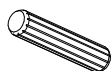

STEP 15

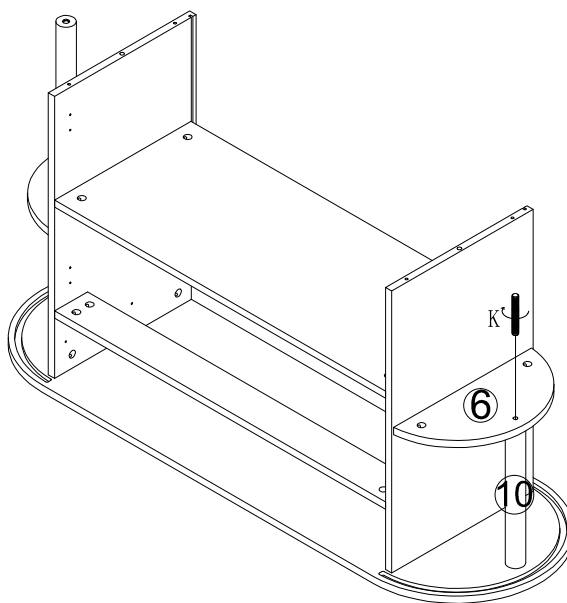

No. K
Quantity: 1 Pcs
M6*55mm

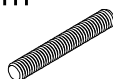

STEP 16

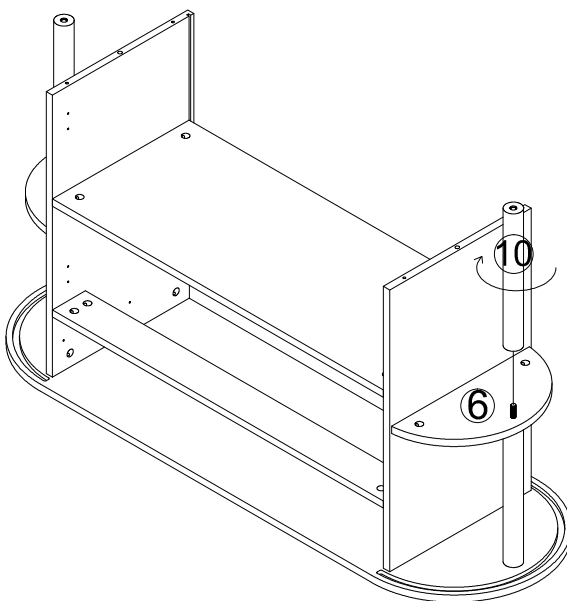

STEP 17

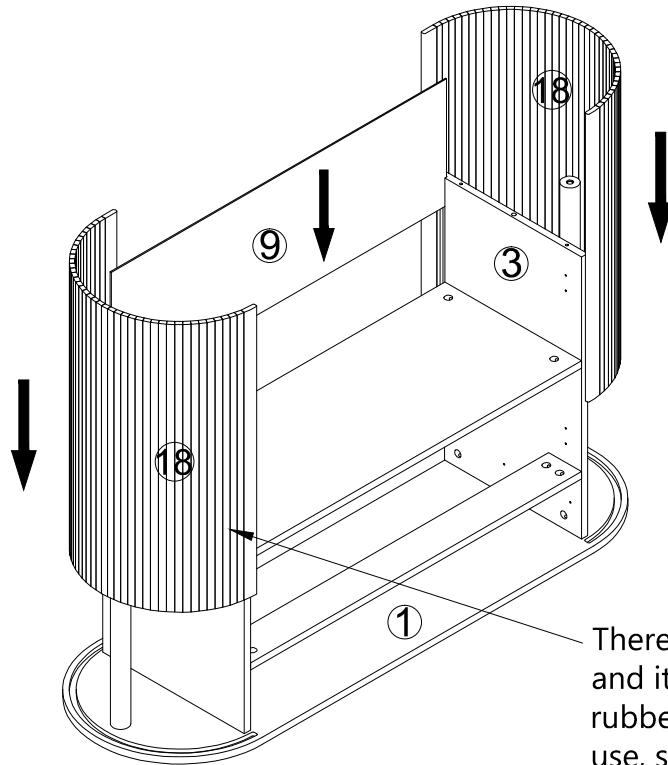

There is wax on the sliding door, and it needs to be pushed and rubbed back and forth before use, so that the wax is evenly attached to the board.

STEP 18

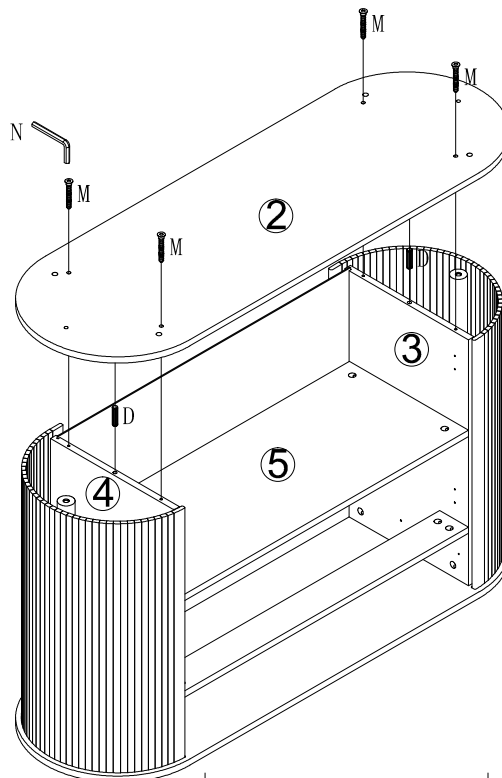

No. D
Quantity: 2 Pcs
8*30mm

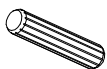

No. M
Quantity: 4 Pcs
M6*40mm



No. N
Quantity: 1 Pcs
4#



STEP 19

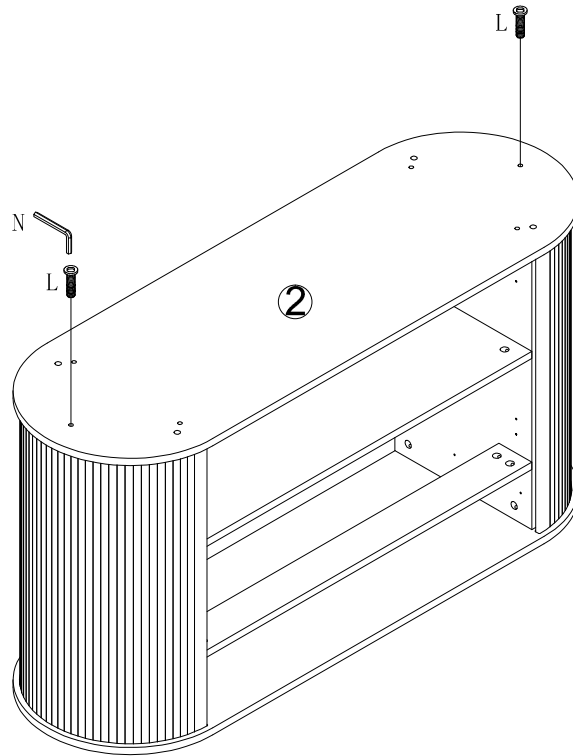

No. L
Quantity: 2 Pcs
M6*35mm



No. N
Quantity: 1 Pcs
4#



STEP 20

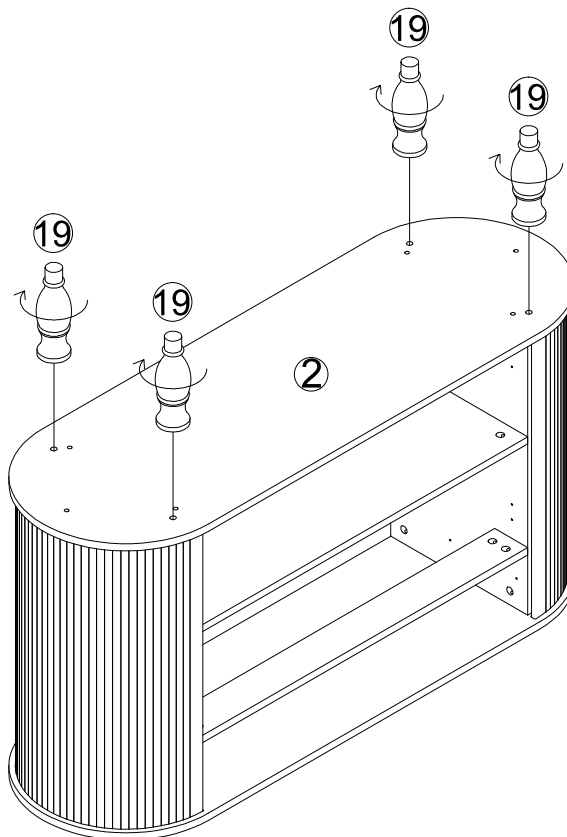

STEP 21

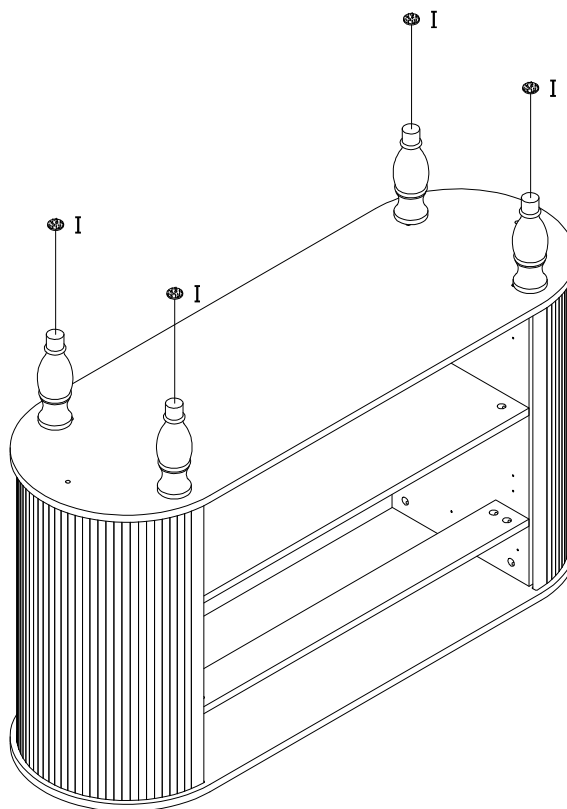

No. I
Quantity: 4 Pcs
Ø20



STEP 22

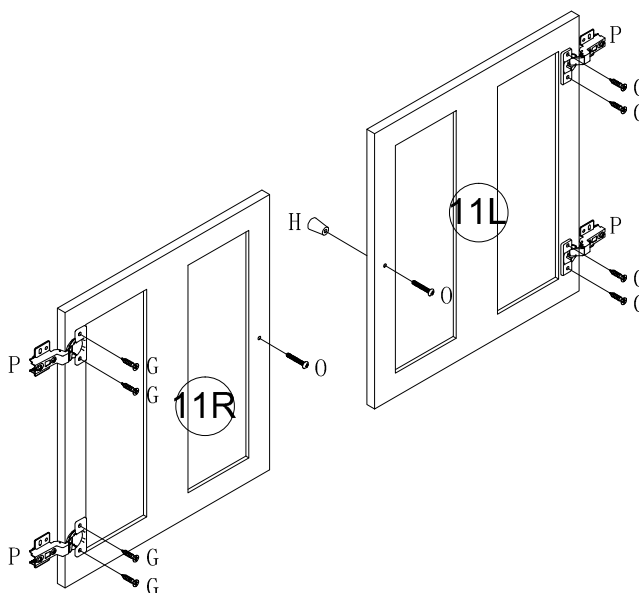

No. G
Quantity: 8 Pcs
M3.5*14mm



No. H
Quantity: 2 Pcs
Ø20*23mm



No. O
Quantity: 2 Pcs
M4*20mm



No. P
Quantity: 4 Pcs

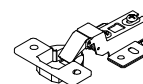

STEP 23

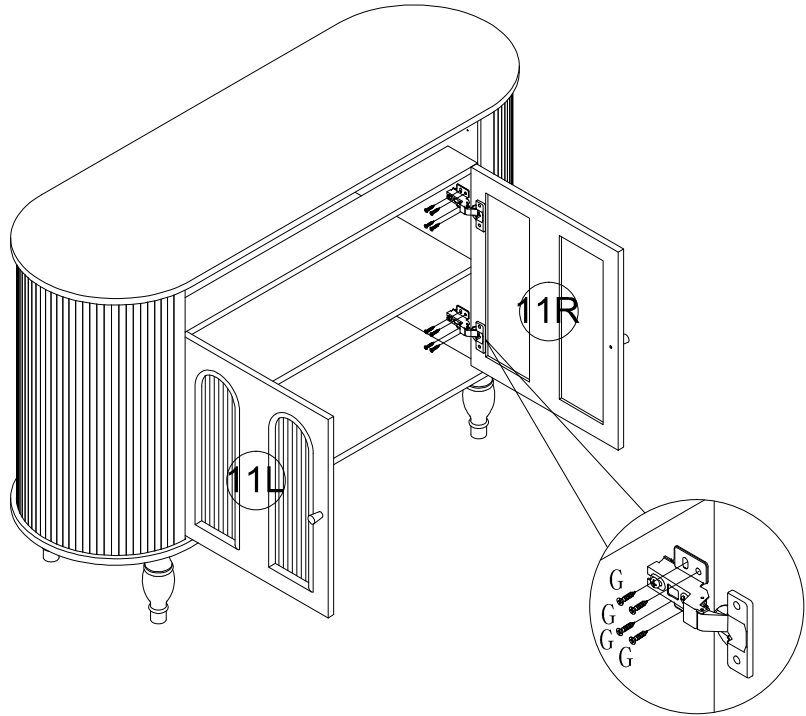
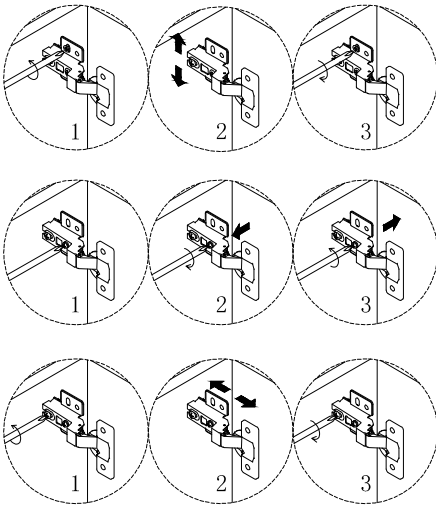

No. G
Quantity: 16 Pcs
M3.5*14mm



STEP 24

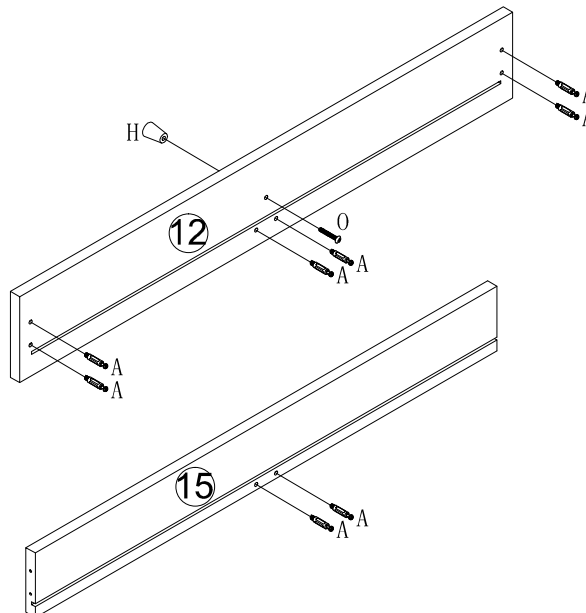

No. A
Quantity: 8 Pcs
8*28 mm



No. H
Quantity: 1 Pcs
Ø20*23mm



No. O
Quantity: 1 Pcs
M4*20mm



STEP 25

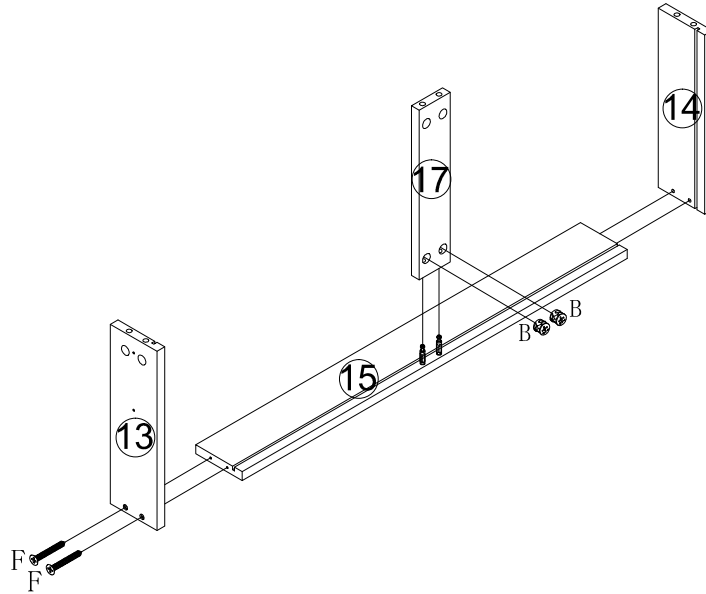

No. B
Quantity: 2 Pcs
Ø15



No. F
Quantity: 4 Pcs
M4*30mm

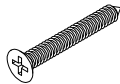

STEP 26

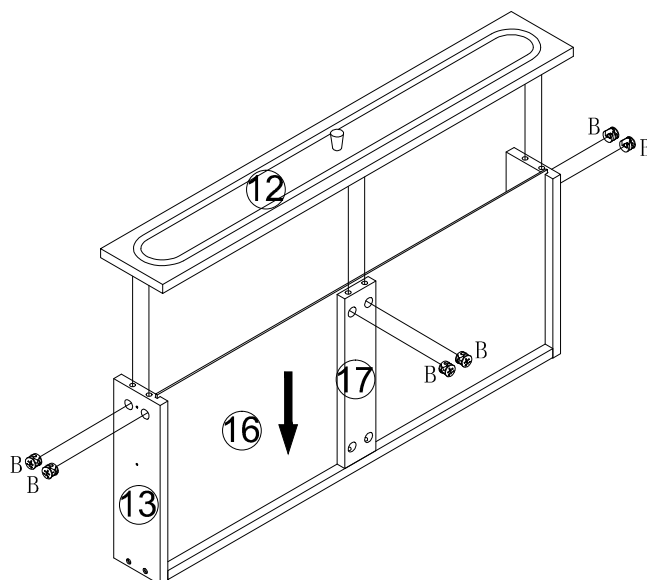

No. B
Quantity: 6 Pcs
Ø15



STEP 27

 back

The first screw hole should corresponded with the board location hole

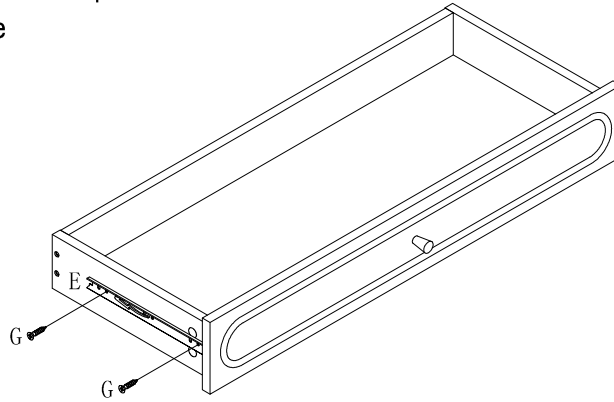

No. E
Quantity: 1 Sets
12"

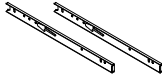

No. G
Quantity: 4 Pcs
M3.5*14mm



STEP 28

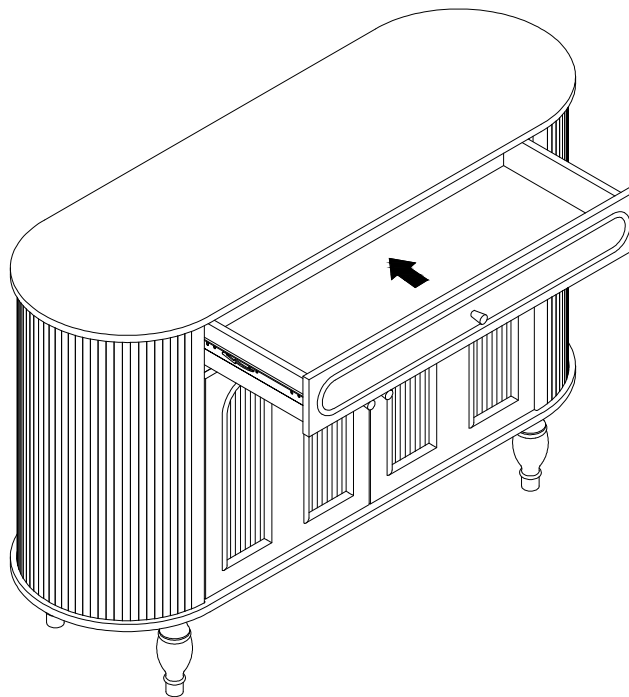

STEP 29

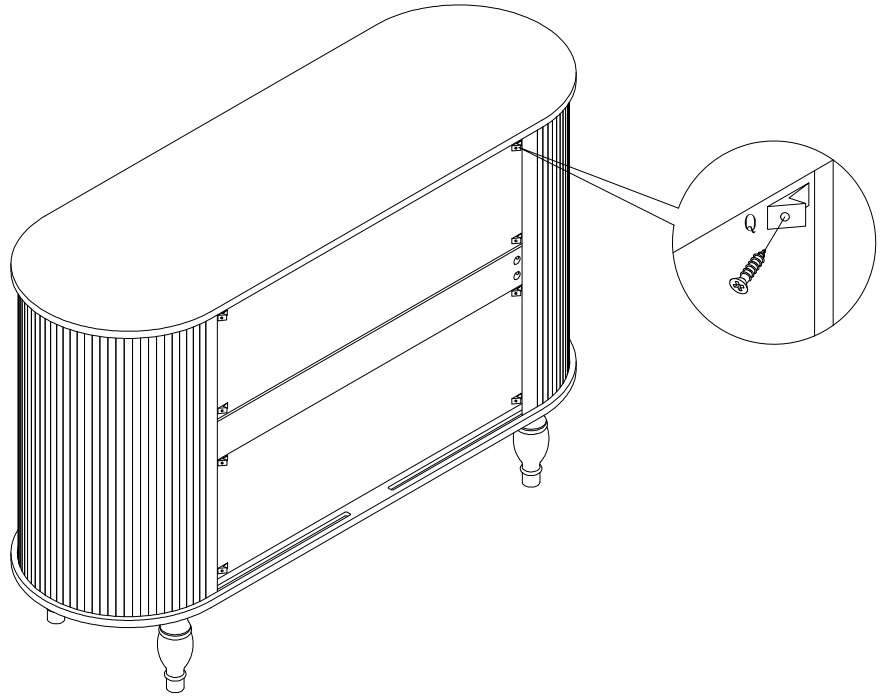

No. Q
Quantity: 8 Sets

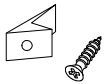

STEP 30

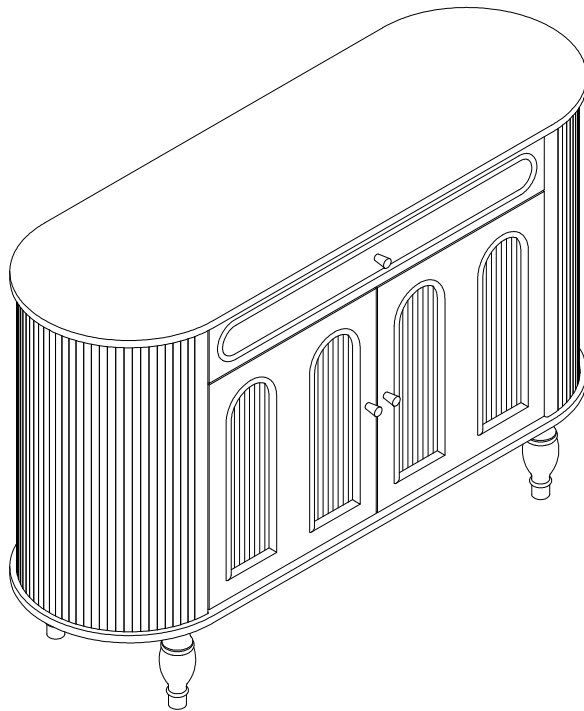

STEP 31

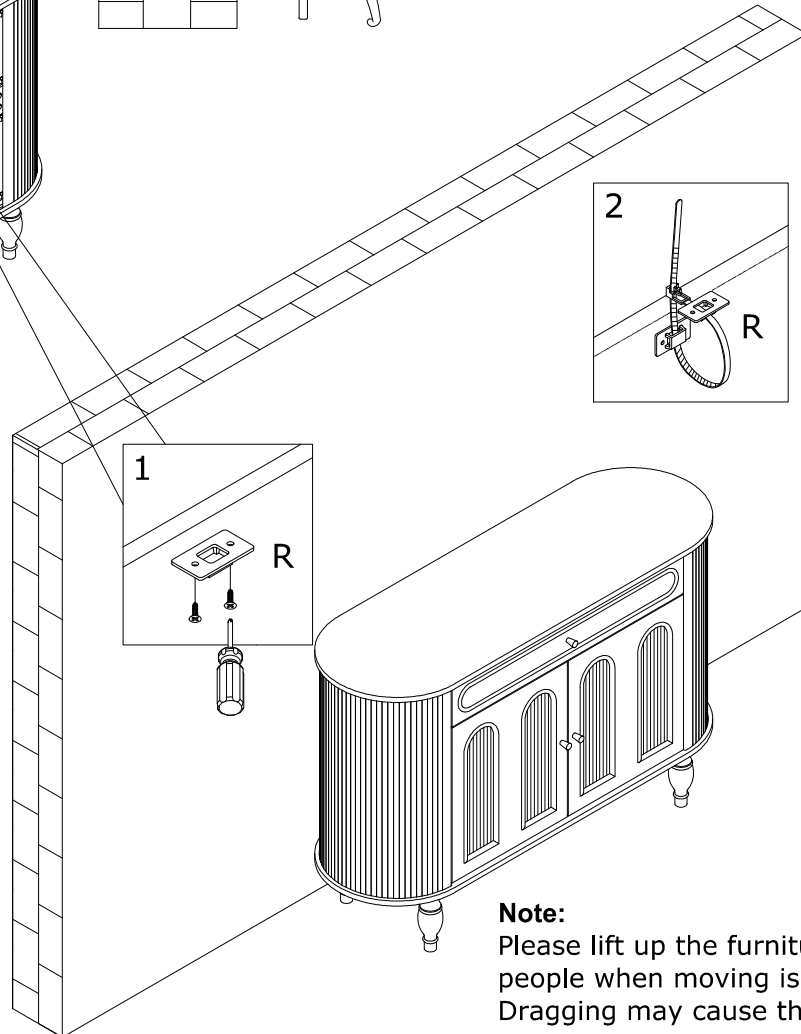
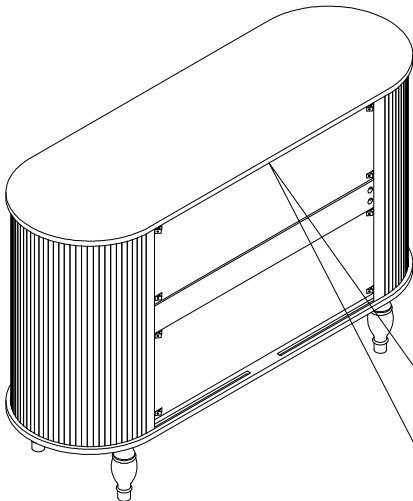
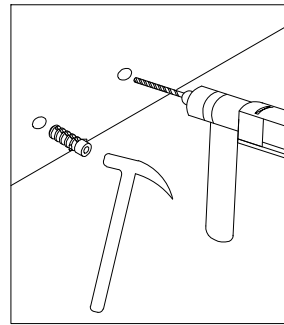
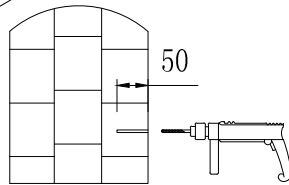
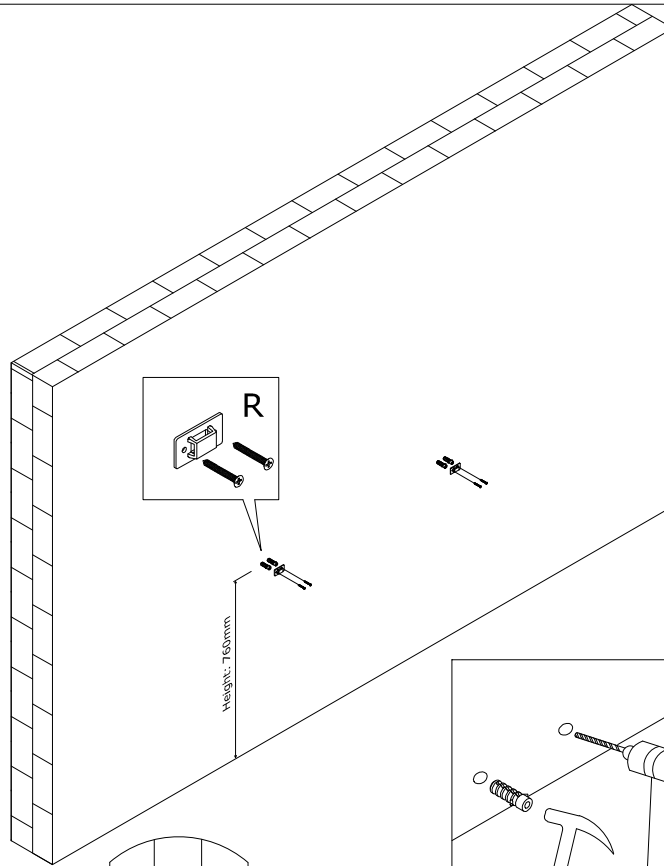

No. R
Quantity: 1 Set

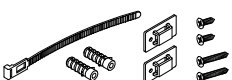

Note:
Please lift up the furniture by two people when moving is needed.
Dragging may cause the legs failure.