

STEP 3

Attach Back Support (C) to the assembled unit by using Screw/Washer/Nut (1).
Note: Fixed the Nut using plier before screwing in the Washer/Screw.

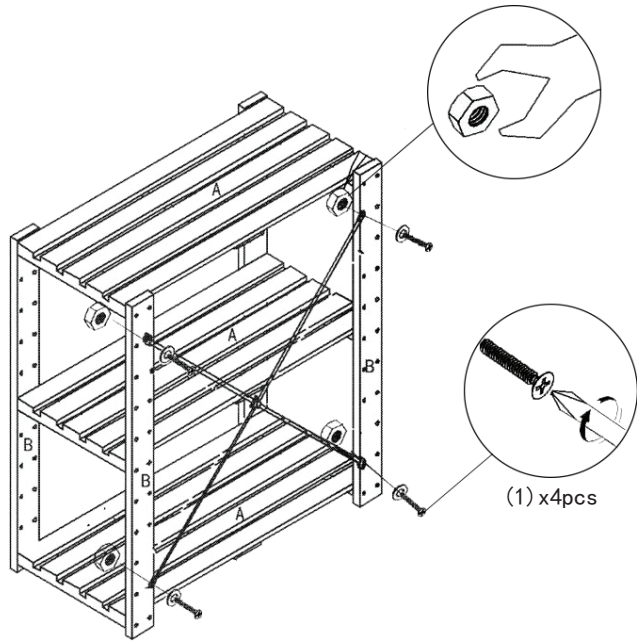

Recommended Maximum Weight

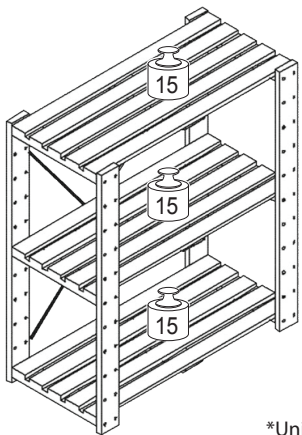

*Unit in Pound(lbs)

WARNING:

>This unit has been designed to support the maximum loads shown. Exceeding these load limits could cause sagging, instability, product collapse, and/or serious injury.

>DO NOT allow children to climb on unit.

>Put heavier items on lower shelves.

Assembly Instruction

Solid Wood 3 Tier Shelf

DIMENSION : 23.6"(W) x 27.2"(H) x 11.2"(D)

00:20

Approx. 20 minutes







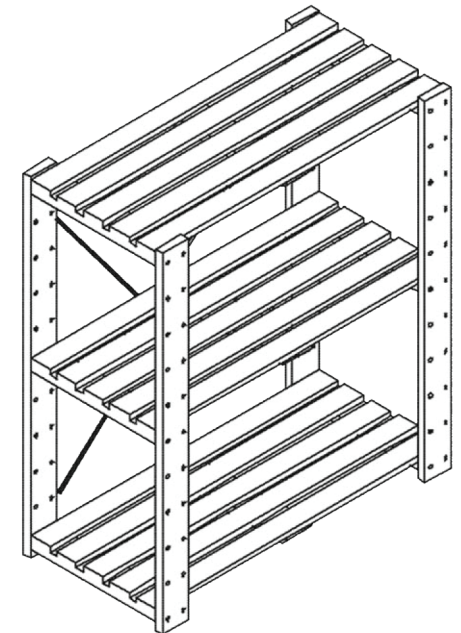

Recomm. 1 Person



Tool Required



No	Hardware List	Qty
1	Screw/Washer/Nut 	4pcs
2	Socket Cap Screw 	24pcs
3	Allen Wrench 	1pcs

No	Parts List	Qty
A	Shelf Panel 	3pcs
B	Support Panel 	4pcs
C	Back Support 	1pcs

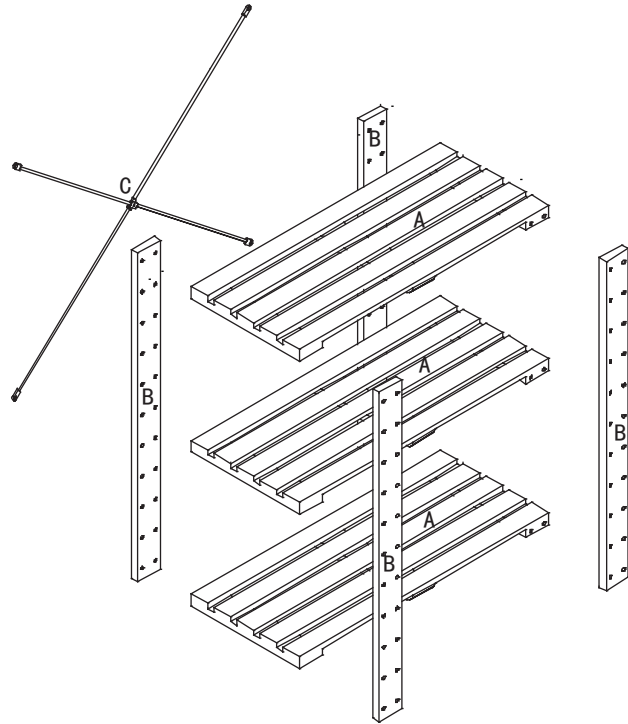

USEFUL HINTS BEFORE YOU START:

1. Read each step carefully before starting.
2. It is important that each step is performed in correct order to avoid difficulties.
3. Identify, sort and count the parts before assembly.
4. Assemble your furniture on packaging cardboard to prevent scratch or damage.
5. Clean the product with mild cleanser using soft damped cloth. Do not use harsh or abrasive cleanser.
6. Using incompatible hardware might cause damage to product.

STEP 1

Attach Support Panel (B) to Shelf Panel (A) using Socket Cap Screw (2).
 Note: Place the end of Support Panel (B) with the stopper pad facing downwards.

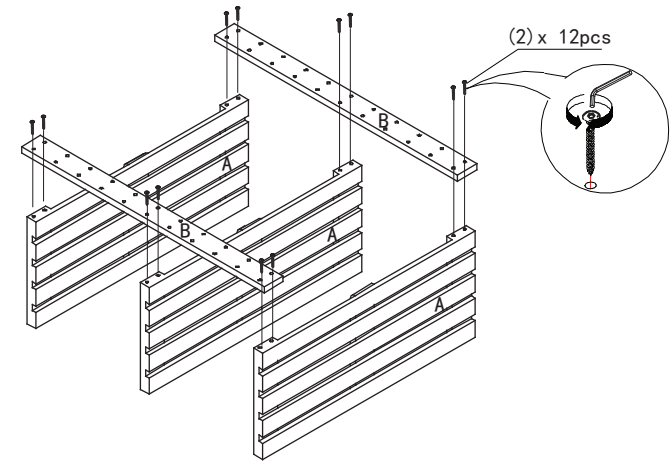

STEP 2

Attach another 2 Support Panel (B) to the other side of the Shelf Panel (A) using Socket Cap Screw (2), as in Step 1.

