

SPEAKMAN®

Refresh™ Accessories

SA-1405

SA-1406

SPECIFICATION



SA-1405

SA-1406

MODELS:

- SA-1405: Paper Holder
- SA-1406: Robe Hook

FEATURES:

- Metal construction

FINISHES:

ADD SUFFIX TO MODEL #

- Polished Chrome (standard)
- Brushed Nickel -BN

WARRANTY:

- 1 year limited

SEE REVERSE FOR ROUGH-IN DIMENSIONS

THIS SPACE FOR ARCHITECT/ENGINEER APPROVAL.

SPEAKMAN®

400 ANCHOR MILL ROAD | NEW CASTLE, DE 19720
P: 800-537-2107 | F: 800-977-2747
WWW.SPEAKMANCOMPANY.COM

REVISION DATE: JANUARY 2014

Management Systems
Registered to ISO 9001

SPEAKMAN®

Refresh™ Accessories

SPECIFICATION

Robe Hook

SA-1406

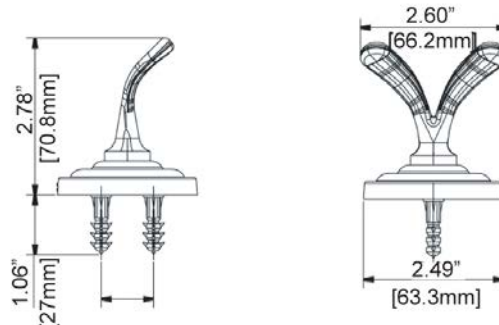

Tissue Paper Holder

SA-1405

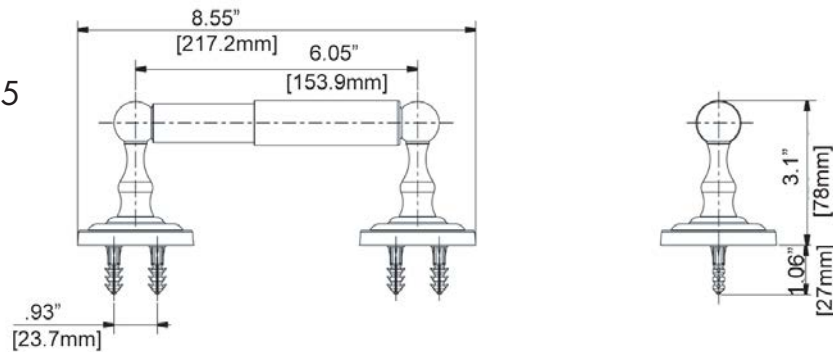

NOTE: 1. All dimensions are in inches (millimeters) unless otherwise specified and are subject to change without notice.

THIS SPACE FOR ARCHITECT/ENGINEER APPROVAL.

SPEAKMAN®

400 ANCHOR MILL ROAD | NEW CASTLE, DE 19720
P: 800-537-2107 | F: 800-977-2747
WWW.SPEAKMANCOMPANY.COM

Management Systems
Registered to ISO 9001

REVISION DATE: JANUARY 2014