

Name: Mos - 03

Design: Joana Bover / 2008

Typology: Pendant lamp

Environment: Indoor





Technical description:

Pendent lamp releasing diffused light through a translucent shade of hand wrapped polyester blend ribbon. Light passes through a white opal glass diffuser, with white, cream or red translucent ribbon options for the shade. The iron structure has a satin nickel finish, available with a transparent PVC wire connection, as well as adjustable tensor wires.

Various tensor wires are available:
1.5, 3, and 5 mt + terminal.



Lamps description

	Grounding: compulsory
	6 x 100 W E26 A19 INC
	6 x 10 W E26 A19 LED
	6 x 20 W E26 Triple CFL

Voltage: 120V~60Hz

 1 Box 49.21 x 49.21 x 43.31 inches

Vol.: 60.699 ft³

Weight: 66.14 lbs

Certifications:  

 Photometrics made according to the position the lights are shown in the catalogue and price list.

Ref Finishings

224P621U White Translucent Ribbon

224P625U Cream Translucent Ribbon

224P626U Red Translucent Ribbon

White polycarbonate diffuser included

Satin nickel

Transparent connection

Adjustable tensor wire

Safety tensor wire

Customizable

Measures

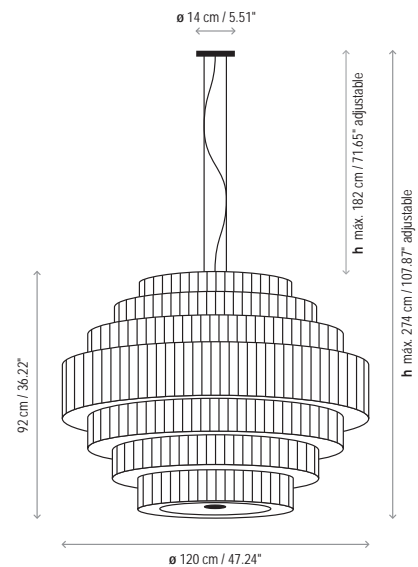

Mos - 01

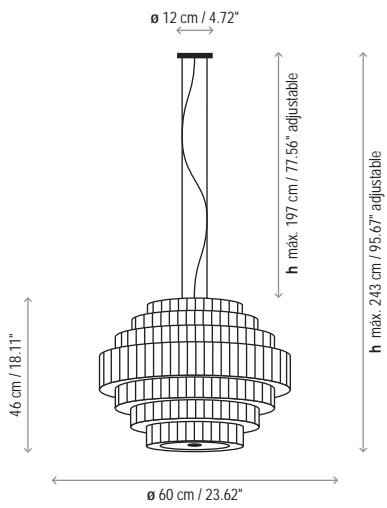

Mos - 02

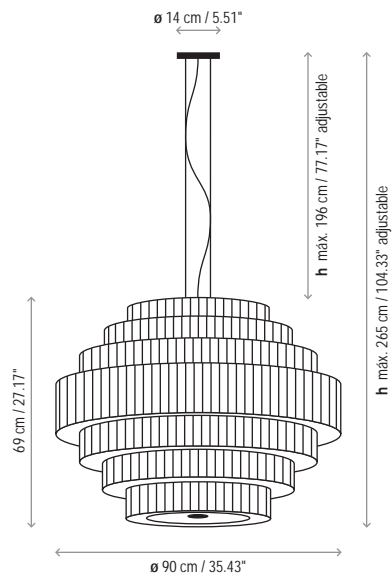

Mos - 03

