

# ASSEMBLY INSTRUCTION

ITEM : 50007

NO	PART LIST	QTY
1	BACK REST	1PC
2	SIDE PANEL (L)	1PC
3	SIDE PANEL (R)	1PC
4	FRONT SIDE RAIL	1PC
5	BACK SIDE RAIL	1PC
6	LEG	4PCS
7	SLAT	2 SET
8	TRUNDLE FRONT RAIL	1PC
9	TRUNDLE BACK RAIL	1PC
10	TRUNDLE SIDE RAIL	2PCS
11	SLAT	2 SET
12	SLAT	3PCS
13	CASTOR	6PCS
ITEM	HARDWARE	QTY
A	JCBB SCREW M8 x 20MM	16PCS
B	JCBC SCREW M6 x 35MM	4PCS
C	JCBC SCREW M6 x 50MM	12PCS
D	JCBC SCREW M6 x 60MM	4PCS
E	SPRING WASHER M6 x 13MM	16PCS
F	FLAT WASHER M6 x 19MM	4PCS
G	FLAT WASHER M6 x 13MM	12PCS
H	SCREW M4 x 16MM	24PCS
I	SCREW M4 x 32MM	16PCS
J	L - KEY M4 x 65MM	1PC
K	L - KEY M5 x 65MM	1PC

STEP 1

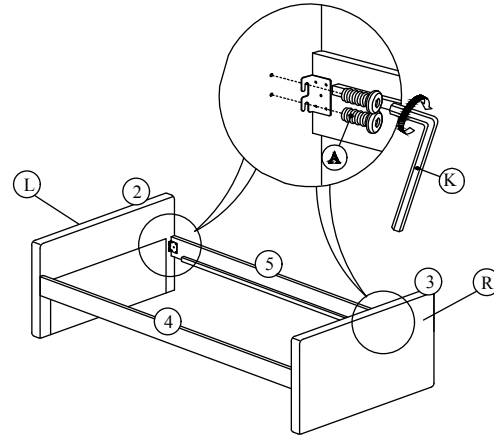

STEP 2

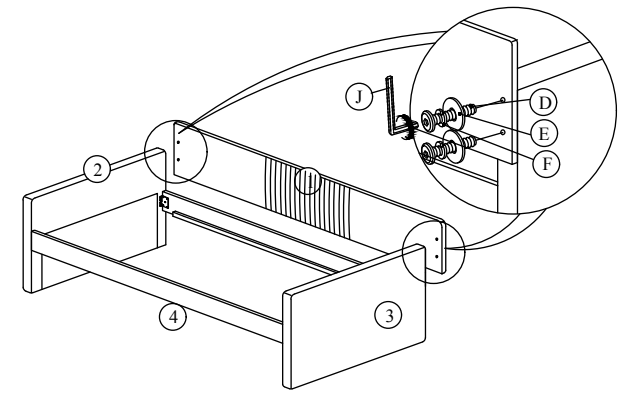

STEP 3

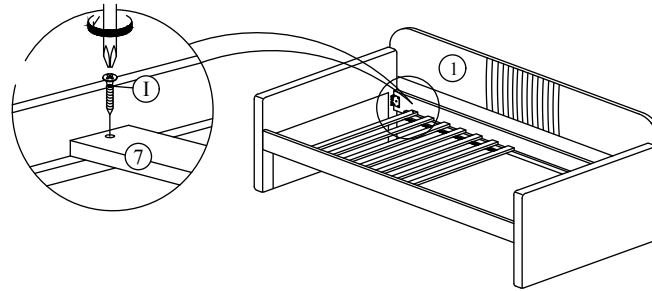

STEP 4

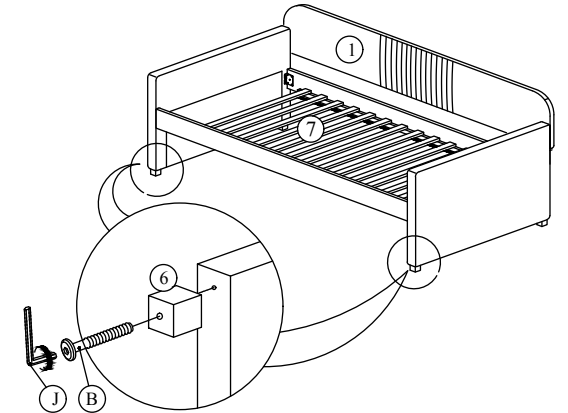

STEP 5

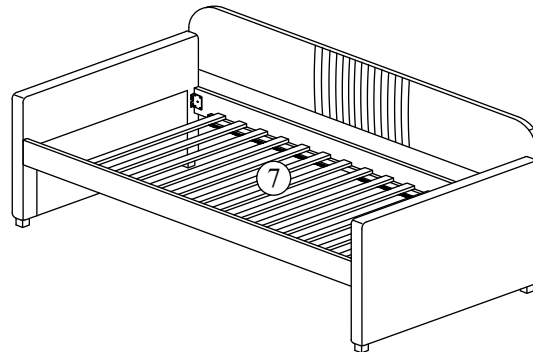

STEP 6

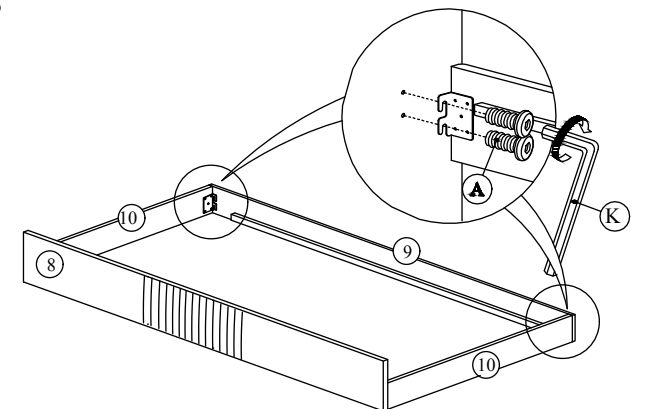

Please do not tighten the hardware until the entire assembly is completed.

# ASSEMBLY INSTRUCTION

STEP 7

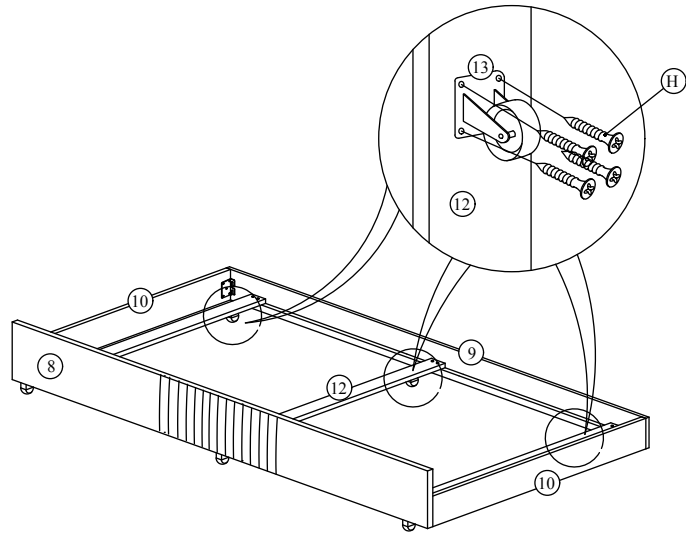

STEP 8

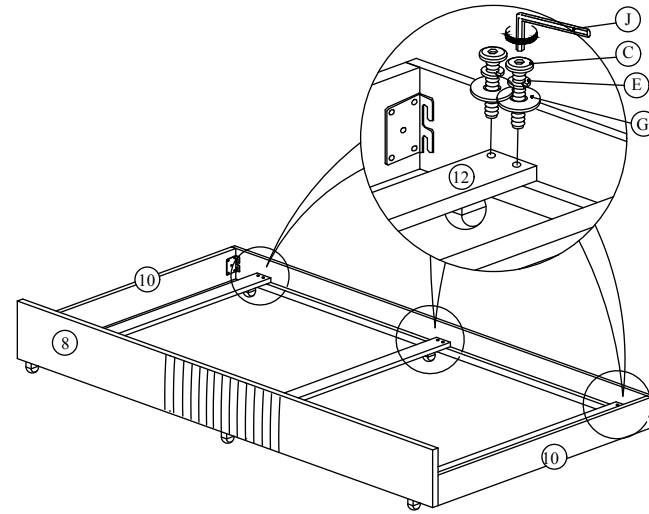

STEP 9

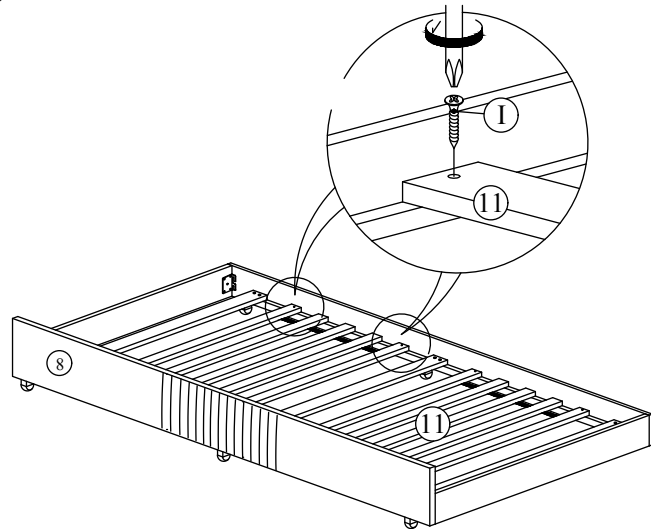

STEP 10

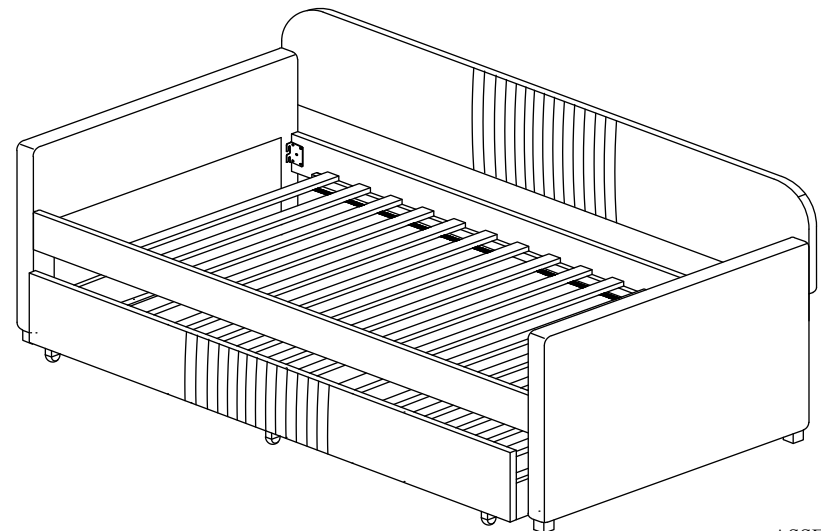

ASSEMBLY  
COMPLETE

Please do not tighten the hardware until the entire assembly is completed.