







ASSEMBLY INSTRUCTIONS

KING BED



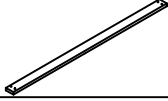

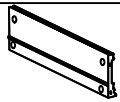
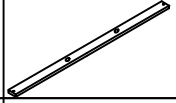



Caution : Please read instructions thoroughly before unpacking assembly parts . Sharp , exposed staple tips can cause injury , therefore , for your protection , please remove any exposed staple used in packing

- 1 . We recommend that you should assemble this product with the assistance of another person ; this will make assembly easier , and will help to eliminate damage to the product or injury to persons during assembly .
- 2 . Be sure to check all packing materials carefully for small parts that may have come loose inside the carton during shipment .
- 3 . please do not over tighten screws or bolts until the assembly is complete .
- 4 . Please put all parts on a non - abrasive floor before assembly , and follow the assembly steps to assemble your newly purchased product correctly and efficiently .

PART LIST

1		HEADBOARD PANEL	1PC
2		HEADBOARD POST LSF	1PC
3		HEADBOARD POST RSF	1PC
4		HEADBOARD CROSS BAR	1PC
5		FOOTBOARD	1PC
6		RAIL	2PCS
7		SLAT	4PCS
8		SUPPORT LEG	8PCS

HARDWARE LIST IN RAIL

A		ALLEN KEY 5/16"	1PC
B		BOLT 5/16"x1-3/4"	12PCS
C		SPRING WASHER 5/16"	12PCS
D		FLAT WASHER 5/16"	12PCS
E		BOLT 5/16" x 3-1/4"	8PCS
F		"C" WASHER 5/16"	8PCS
G		HEX NUT 5/16"	8PCS
H		WRENCH 13x90MM	1PC
J		WOOD SCREW #8 x 1"	8PCS

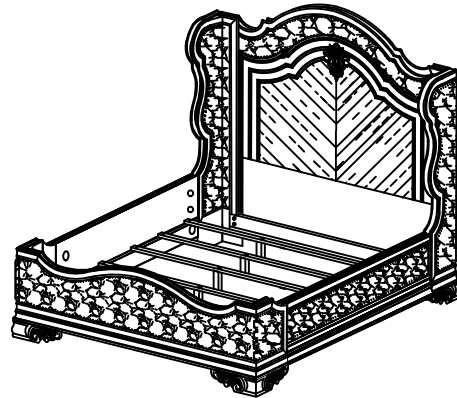

STEP 1

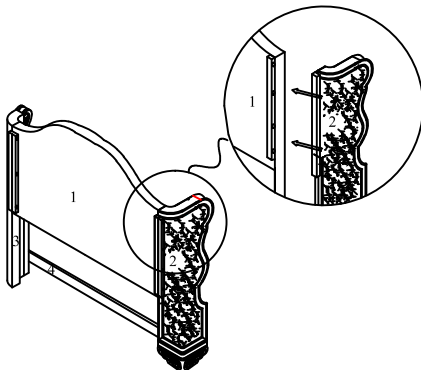

STEP 2

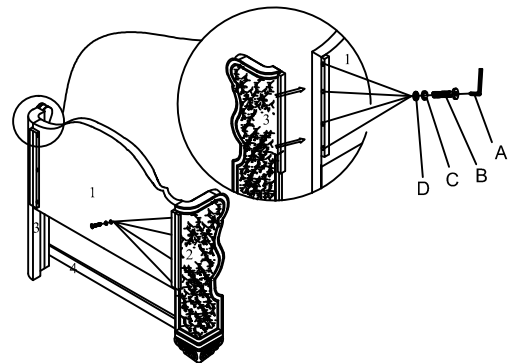

STEP 3

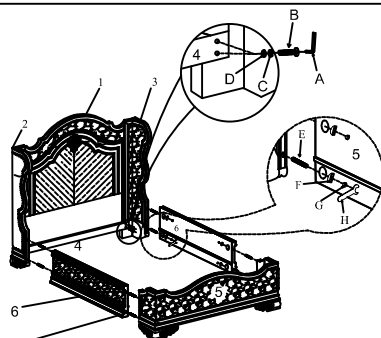

STEP 4

