

ATHENS ROUND COFFEE TABLE SET ASSEMBLY INSTRUCTIONS

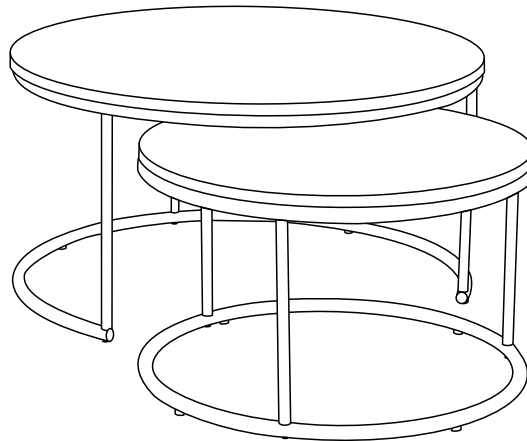

IMPORTANT FOR DOMESTIC USE ONLY PLEASE READ BEFORE YOU CONTINUE FURTHER

THE PRODUCT YOU HAVE PURCHASED WILL GIVE YOU MANY YEARS OF SERVICE IF YOU FOLLOW THE GUIDELINES FOR ITS SAFE ASSEMBLY AND PERIODIC MAINTENANCE AND CLEANING .

ASSEMBLE ON A SOFT CLEAN SURFACE

DO NOT USE ANY TOOLS OTHER THAN THOSE SHOWN.

ANY SPANNERS OR ALLEN KEYS REQUIRED ARE INCLUDED WITH THE FITTINGS KIT.

DO NOT FOR ANY REASON USE A POWER TOOL TO ASSEMBLE THIS PRODUCT. ITS USE WILL INVALIDATE ANY CLAIM YOU MAY HAVE AND COULD MAKE THIS PRODUCT UNSAFE.

DEPENDING ON THE AMOUNT OF USE THIS PRODUCT RECEIVES IT MAY BE NECESSARY TO TIGHTEN UP THE FIXINGS FROM TIME TO TIME . THIS IS COMPLETELY NORMAL FOR ANY FLAT PACK FURNITURE.
DO NOT OVERTIGHTEN FIXINGS.

FOR CLEANING, YOU MAY USE A DAMP CLOTH (NOT WET) DO NOT USE POLISH, DETERGENT OR CHEMICAL CLEANERS.

THIS PRODUCT MAY STAIN OR MARK IF ALLOWED TO COME INTO CONTACT WITH WET OR DAMP OBJECTS.

THE SURFACE OF THIS ITEM IS NOT HEAT RESISTANT. ALWAYS USE A PLACE MAT UNDER HOT OR COLD ITEMS TO PREVENT MARKING.

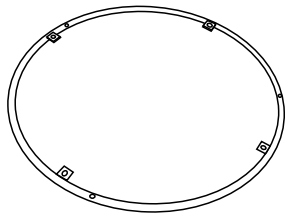

1

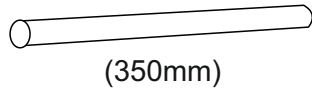

2

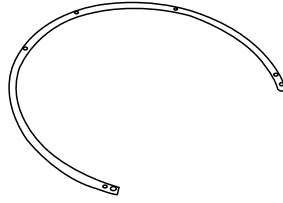

3

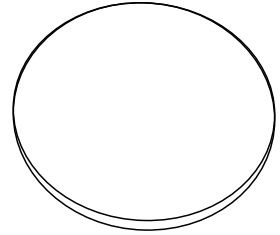

4

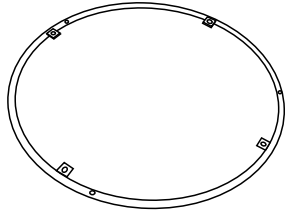

5

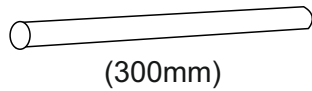

6

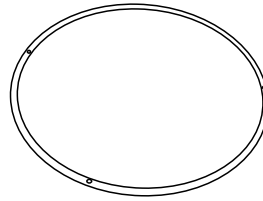

7

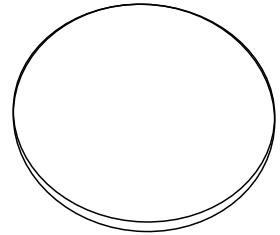

8

PARTS LIST

Part Number	Part Code	Part Description	Quantity	Carton
1	S300-301-054-SF1-01	Metal Frame (Top) - Large	1	1/1
2	S300-301-054-SF1-02	Table Leg - Large (350mm)	1	1/1
3	S300-301-054-SF1-03	Metal Frame (Bottom) - Large	1	1/1
4	S300-301-054-SF1-04	Table Top - Large	1	1/1
5	S300-301-054-SF1-05	Metal Frame (Top) - Small	1	1/1
6	S300-301-054-SF1-06	Table Leg - Small (300mm)	1	1/1
7	S300-301-054-SF1-07	Metal Frame (Bottom) - Small	1	1/1
8	S300-301-054-SF1-08	Table Top - Small	1	1/1

HARDWARE LIST

REF		HARDWARE NAME	QTY
A		Bolts M6x35mm	12PCS
B		Bolts M6x13mm	8PCS
C		Adjusting Foot	8PCS
D		Allen Key M6	1PC

PLEASE CHECK THAT YOU HAVE ALL THE PARTS LISTED BEFORE YOU START ASSEMBLING. IF YOU DO FIND THAT SOMETHING IS MISSING. DO NOT CONTINUE ASSEMBLY. PLEASE CONTACT YOUR SUPPLIER IMMEDIATELY.

STEP 1

PARTS REQUIRED

1 - METAL FRAME TOP-LARGE x1

2 - TABLE LEG LARGE-350mm x3

HARDWARE REQUIRED

A  03

TOOLS REQUIRED

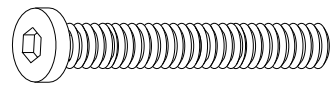

M6x35mm

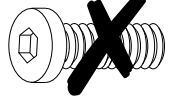

M6x13mm

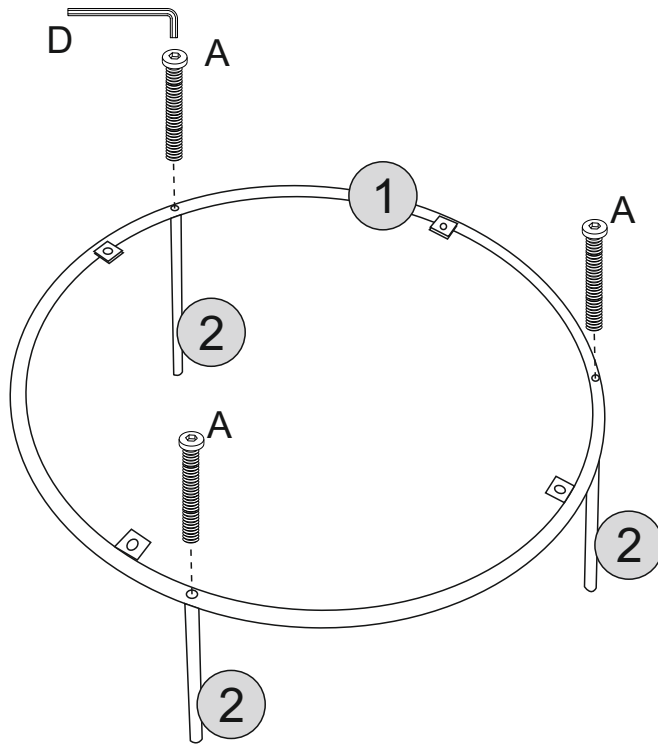

STEP 2

PARTS REQUIRED

3 - METAL FRAME BOTTOM-LARGE x1

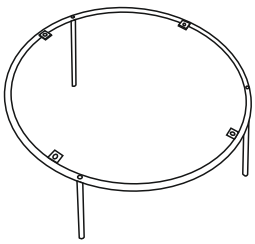

HARDWARE REQUIRED

A  03

TOOLS REQUIRED

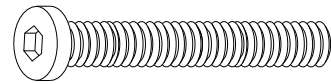
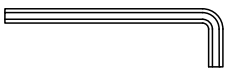

M6x35mm

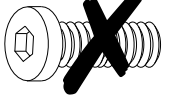

M6x13mm

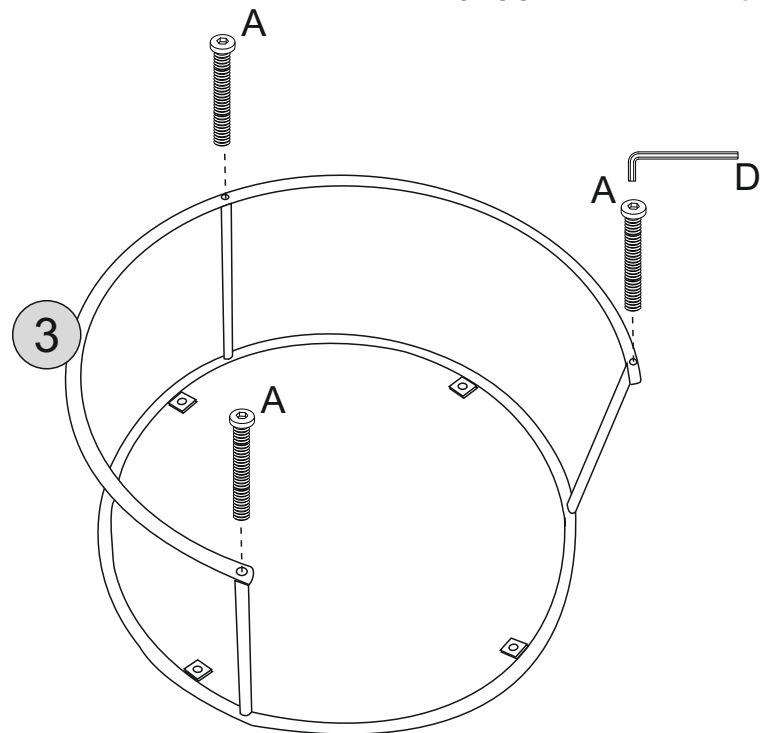



STEP 3

PARTS REQUIRED

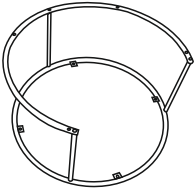
4 - TABLE TOP-LARGE x1



HARDWARE REQUIRED

B		04
C		04

TOOLS REQUIRED

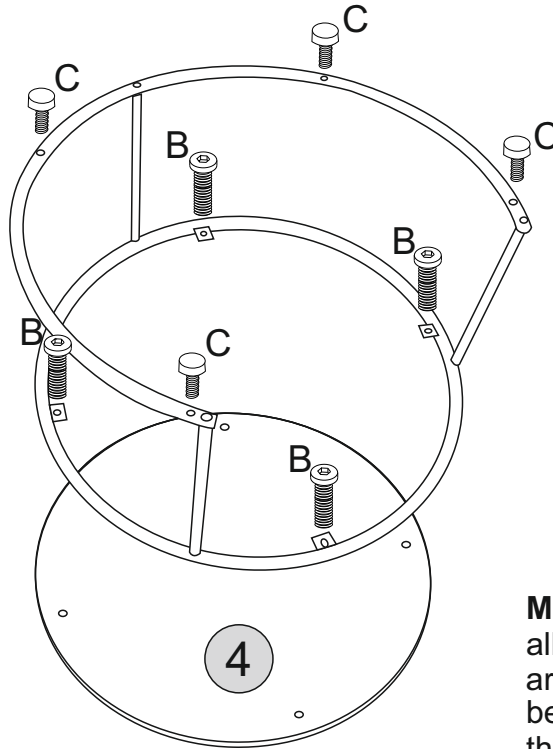
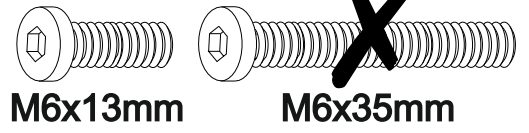

Make sure that
all the bolts (A)
are fully tightened
before attaching
the frame to the
table top (part 4)

STEP 4

PARTS REQUIRED

HARDWARE REQUIRED

TOOLS REQUIRED

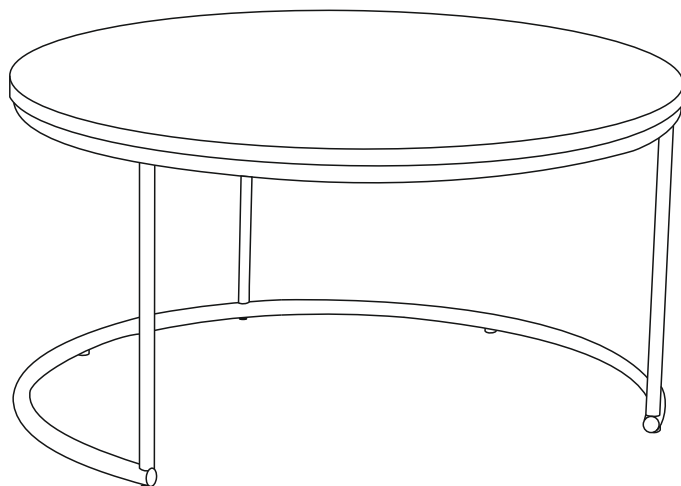

STEP 5

PARTS REQUIRED

5 - METAL FRAME TOP-SMALL x1

6 - TABLE LEG SMALL-300mm x3

HARDWARE REQUIRED

A  03

TOOLS REQUIRED

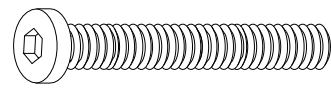

M6x35mm

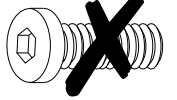

M6x13mm

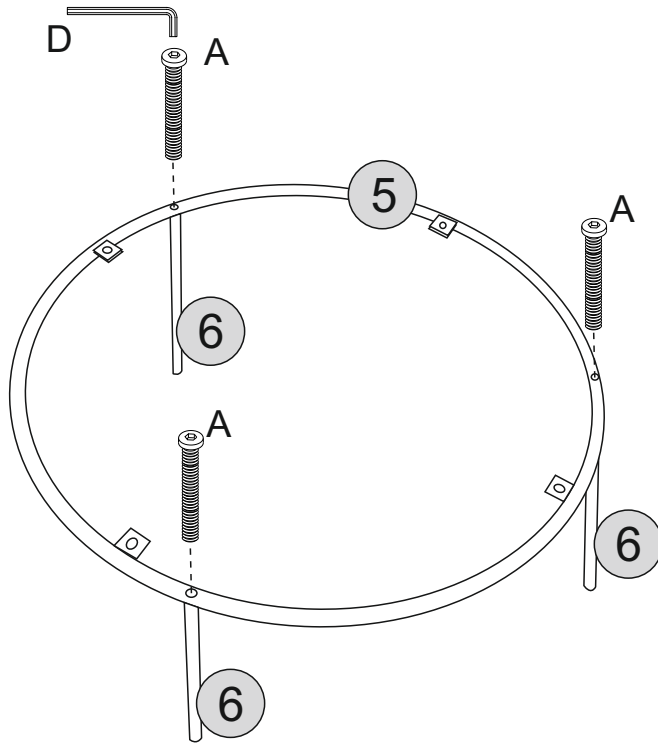

STEP 6

PARTS REQUIRED

7 - METAL FRAME BOTTOM-SMALL x1

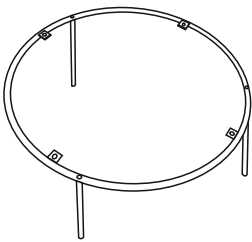

HARDWARE REQUIRED

A  03

TOOLS REQUIRED

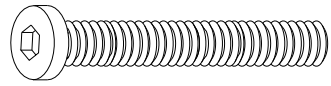
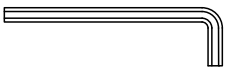

M6x35mm

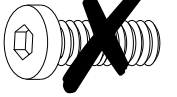

M6x13mm

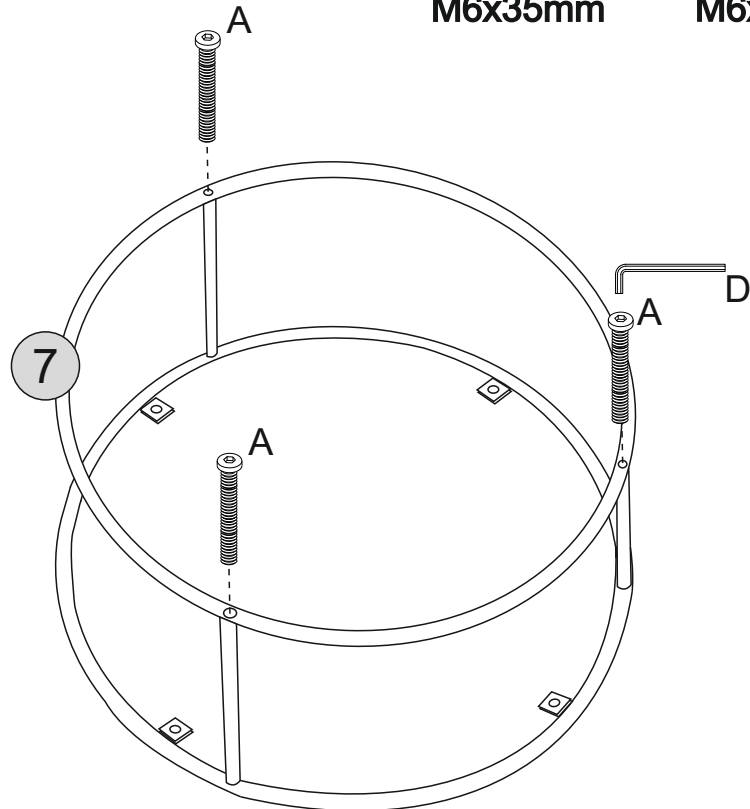

STEP 7

PARTS REQUIRED

8 - TABLE TOP-SMALL x1

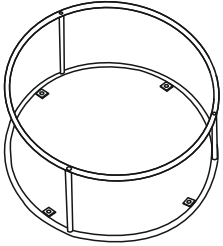

HARDWARE REQUIRED

B  04

C  04

TOOLS REQUIRED



 M6x13mm

~~~~ M6x35mm

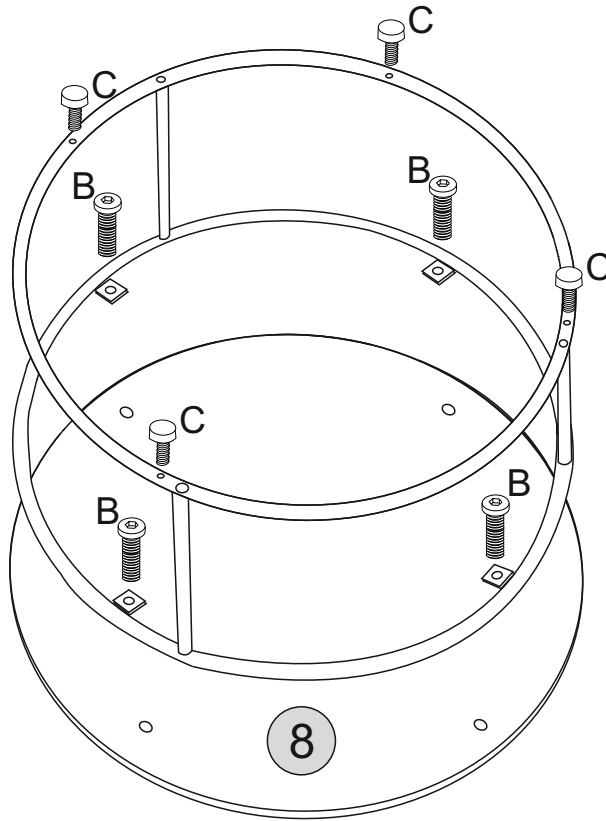

Make sure that all the bolts (A) are fully tightened before attaching the frame to the table top (part 8)

STEP 8

PARTS REQUIRED

HARDWARE REQUIRED

TOOLS REQUIRED

