

INSTALLATION MANUAL

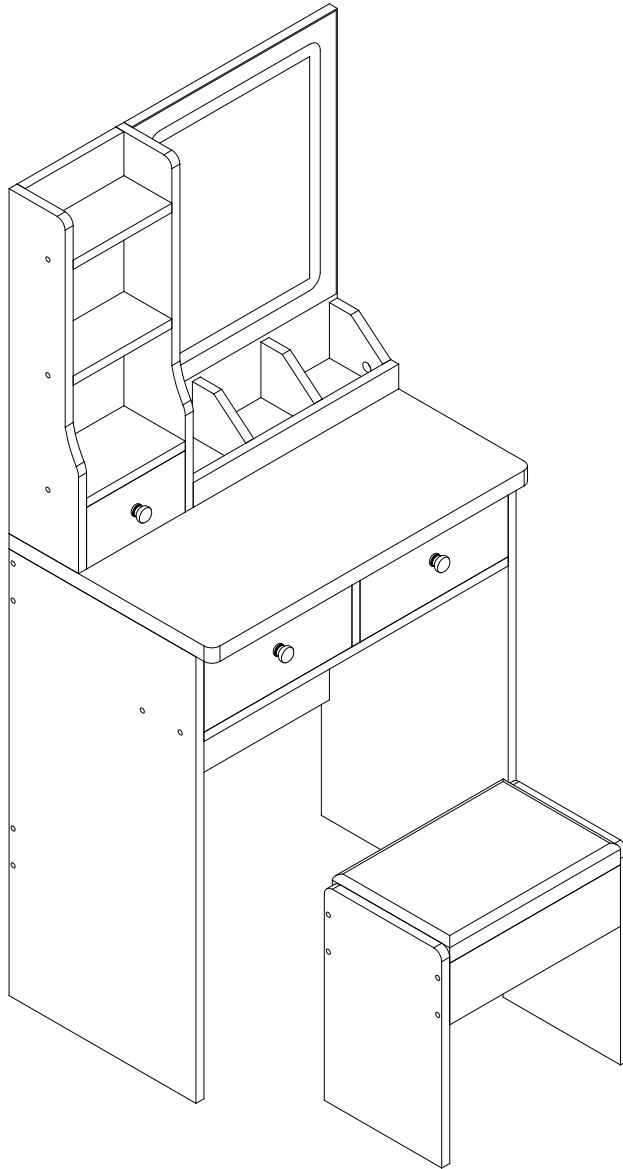

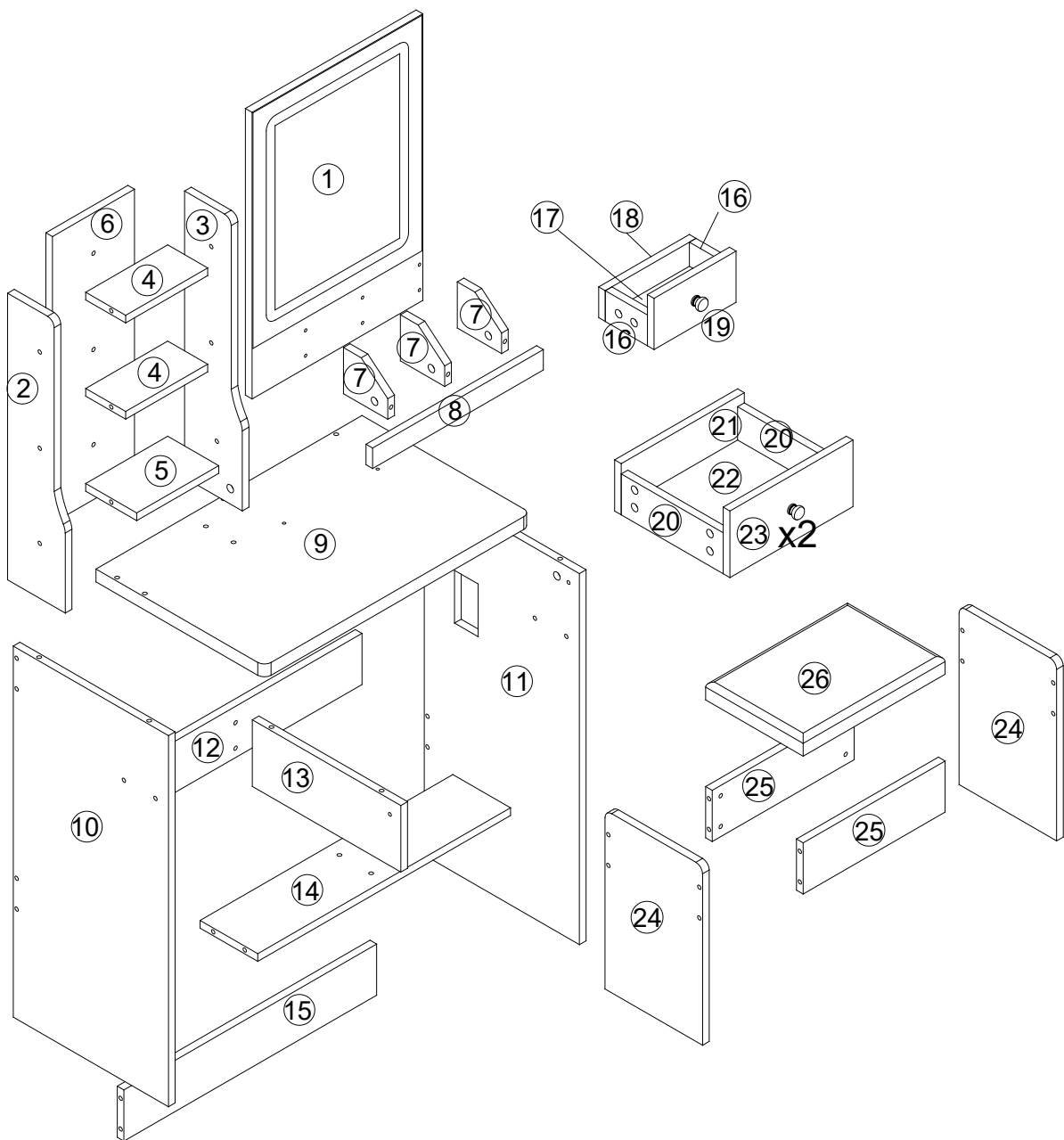

1 - xl	8 - xl	15 - xl	22 - x2
2 - xl	9 - xl	16 - x2	23 - x2
3 - xl	10 - xl	17 - xl	24 - x2
4 - x2	11 - xl	18 - xl	25 - x2
5 - xl	12 - xl	19 - xl	26 - xl
6 - xl	13 - xl	20 - x4	
7 - x3	14 - xl	21 - x2	

HARDWARE

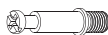

A	SCREW & PLASTIC LOCK	x35
---	----------------------	-----



B	SCREW & METAL LOCK	x35
---	--------------------	-----



C	SCREW	x21
---	-------	-----



D	HAND IN HAND	x3
---	--------------	----



E	HANDLE	x3
---	--------	----



F	SOCKET	x1
---	--------	----



G	SCREW	x4
---	-------	----

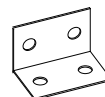

H	L-PLATE	x2
---	---------	----

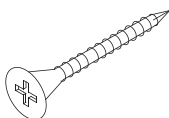

J	SCREW	x33
---	-------	-----



K	SCREW	x33
---	-------	-----



L	HAIR DRYER STAND	x1
---	------------------	----

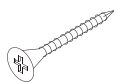

M	SCREW	x8
---	-------	----

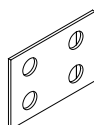

N	METAL PLATE	x2
---	-------------	----

1. Screw installation method

When the screw is installed, please keep it in line with the board, and do not tighten it too tightly

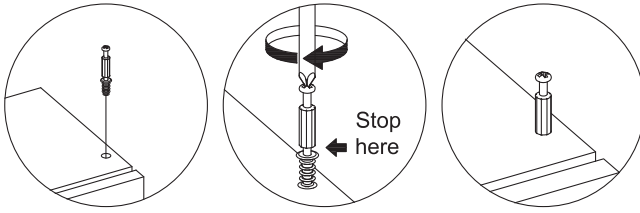

2. Check the Nut direction

This direction of the marked nut is consistent with the direction in which the screw is inserted

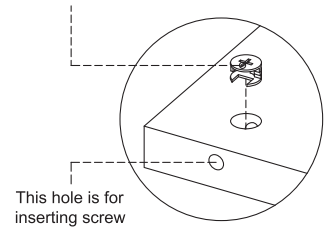

3. Installation on the board with fixing screws

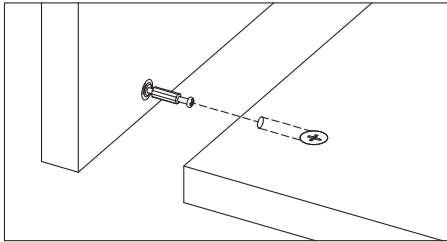

3. Rotate slowly until it stops

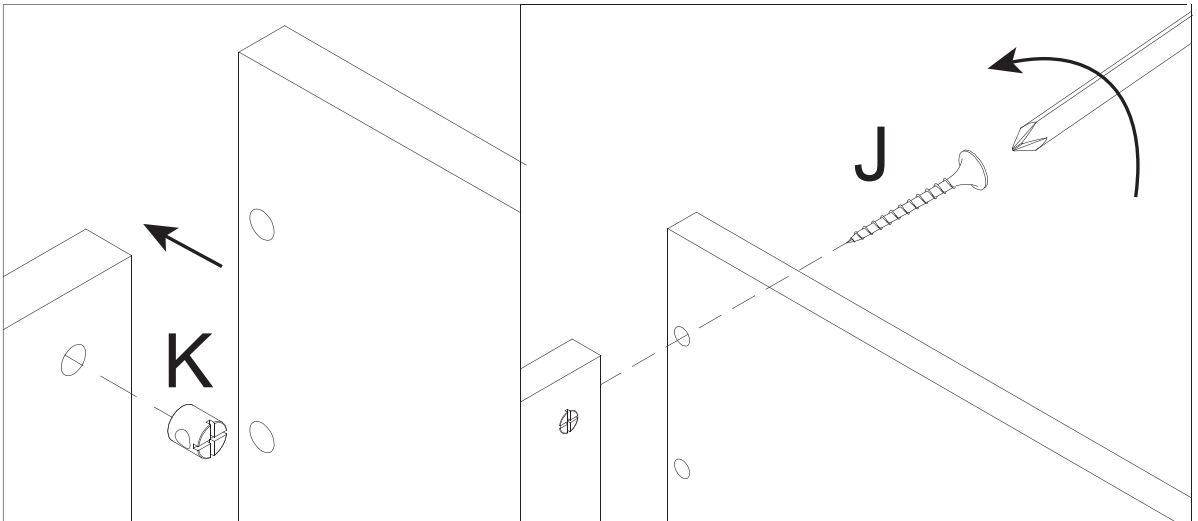
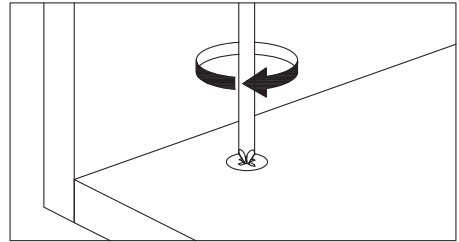

Step 01

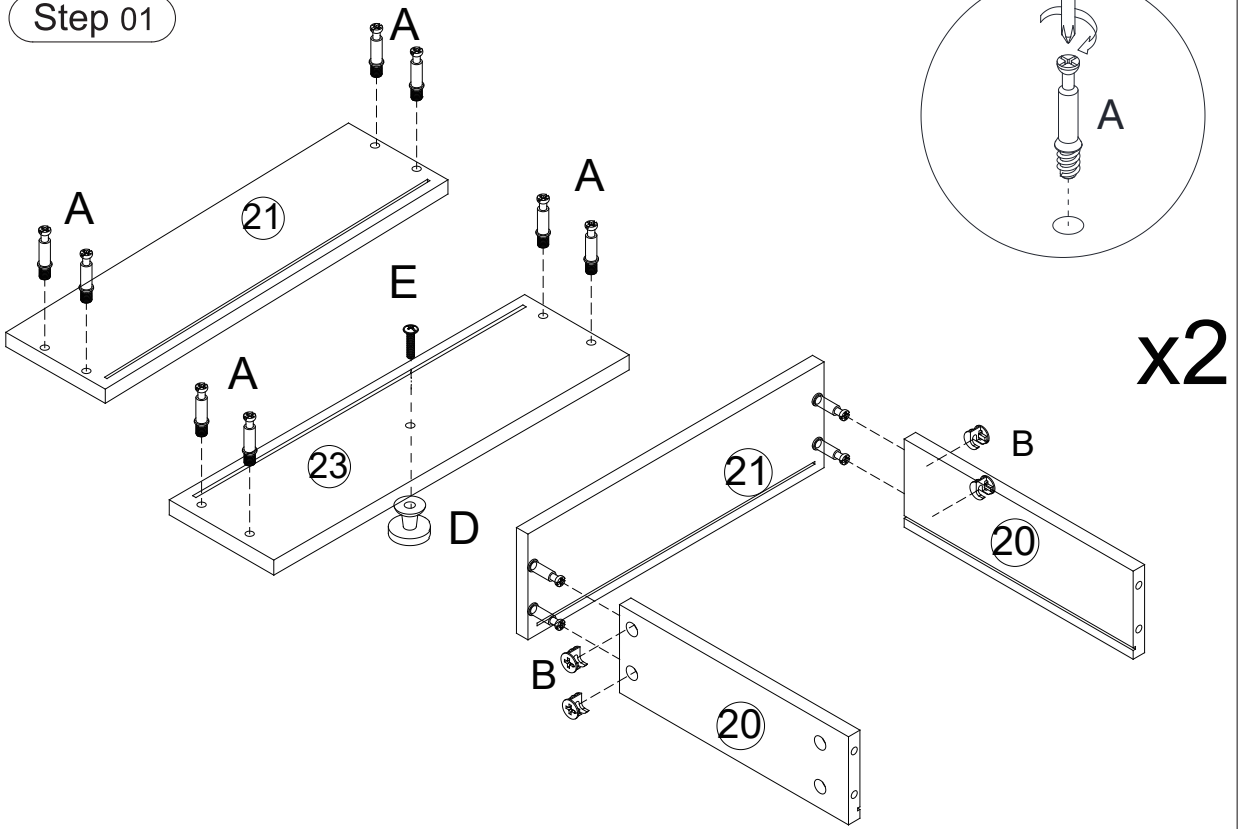

Step 02

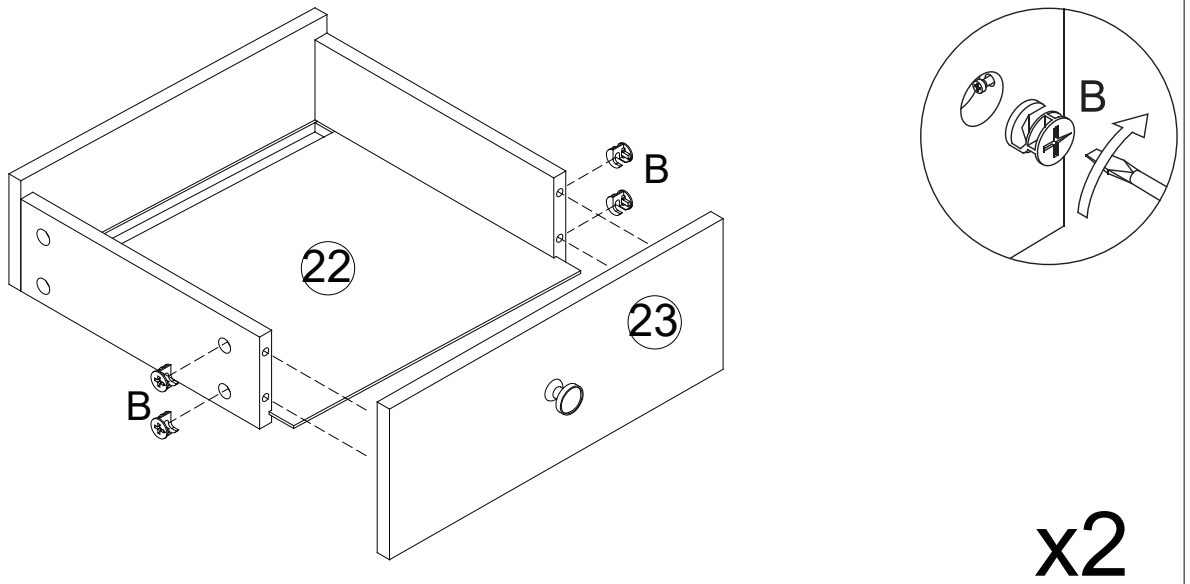

Step 03

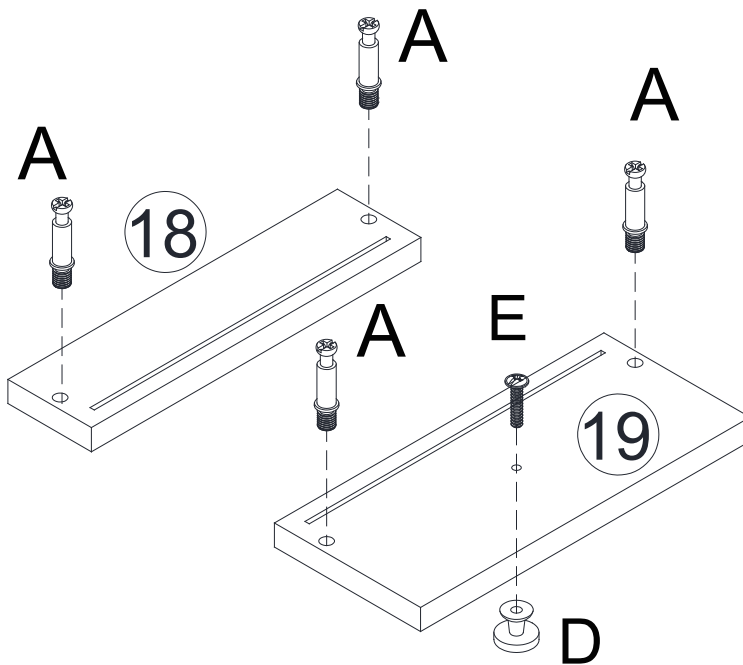

Step 04

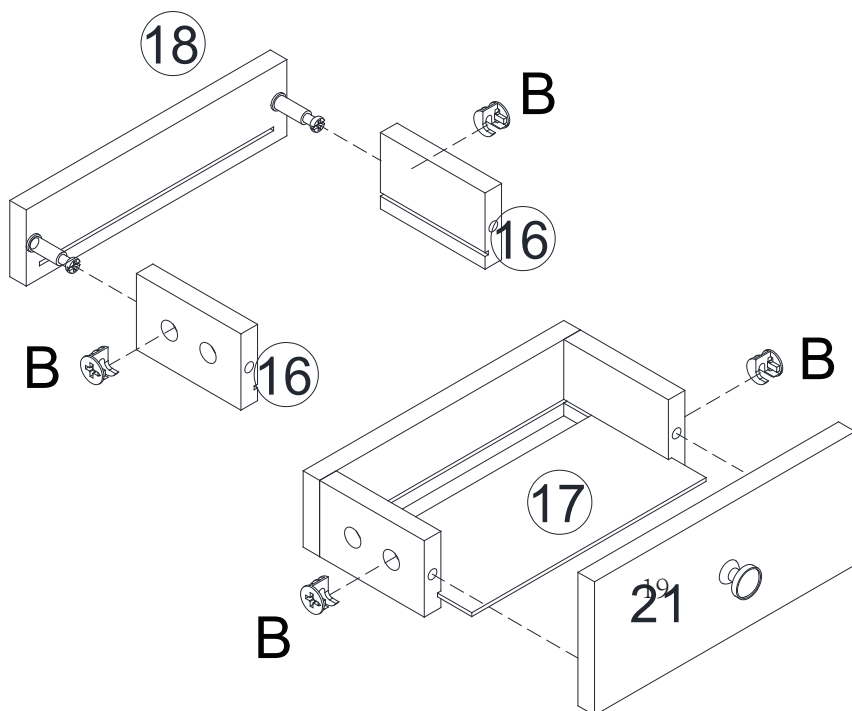

Step 05

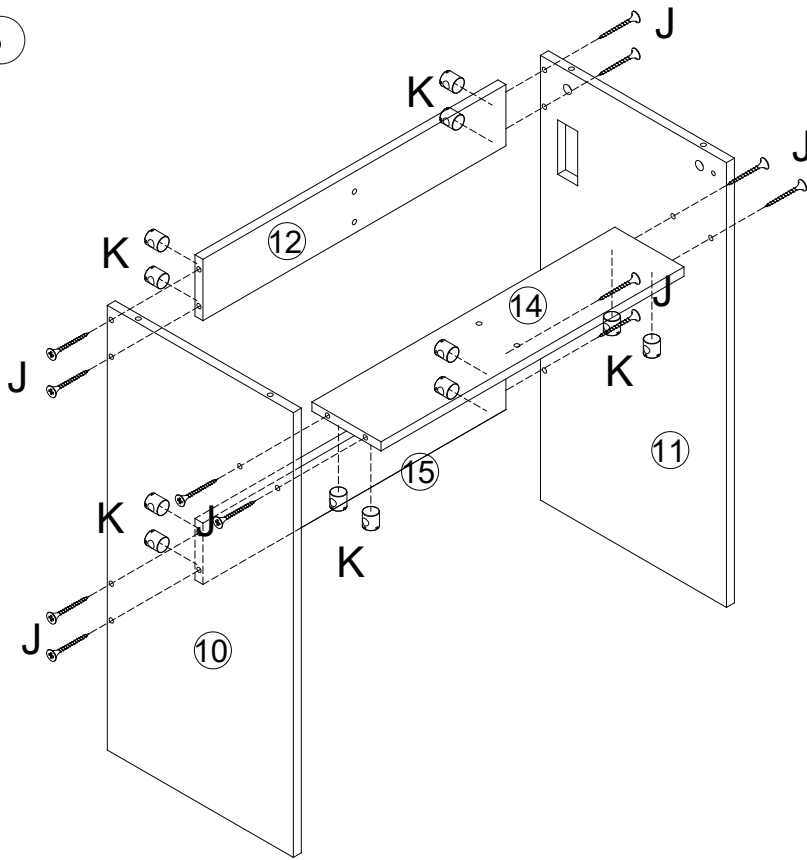

Step 06

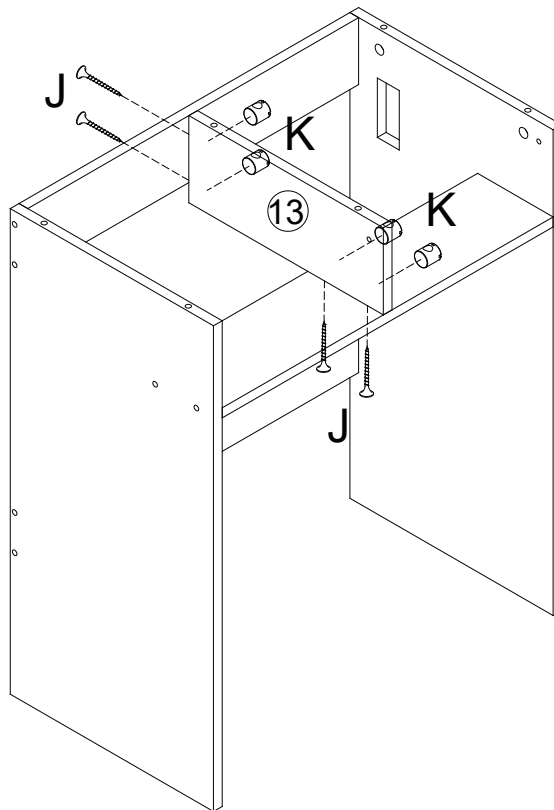

Step 07

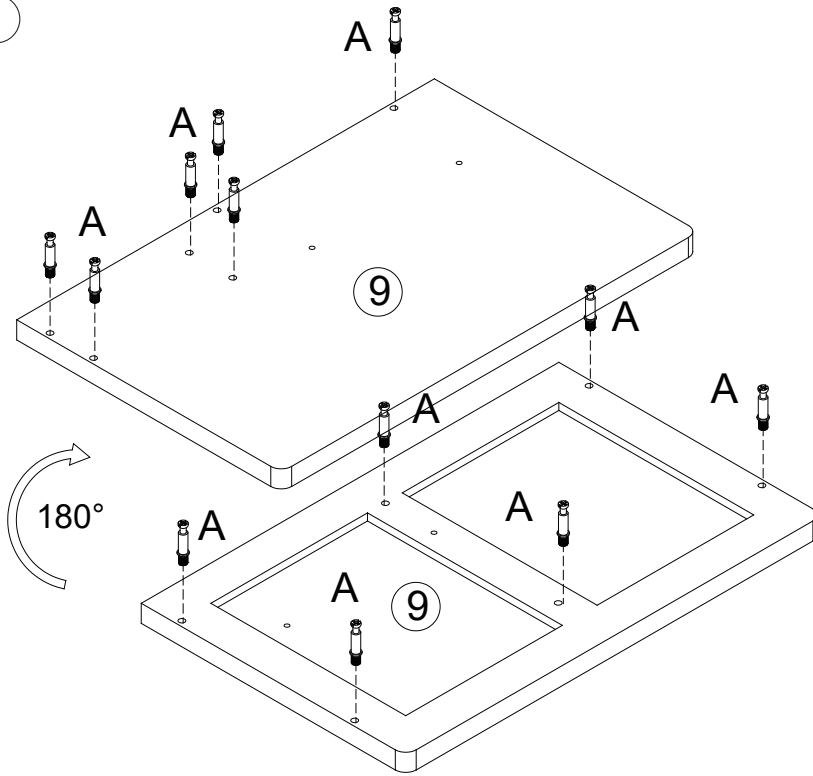

Step 08

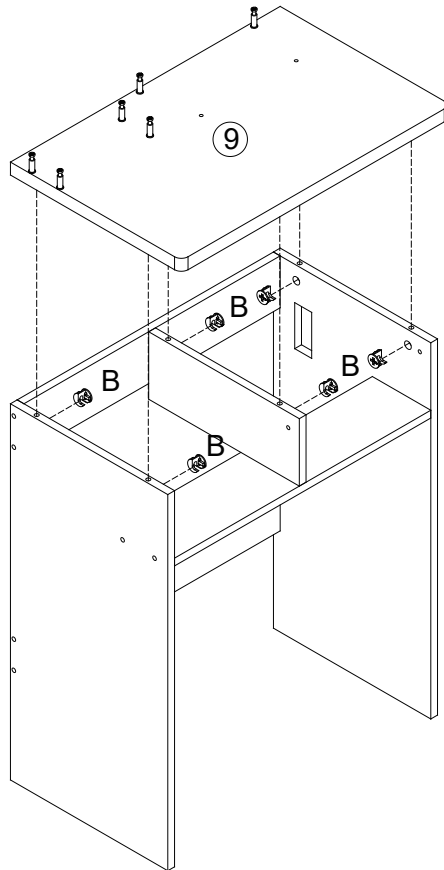

Step 09

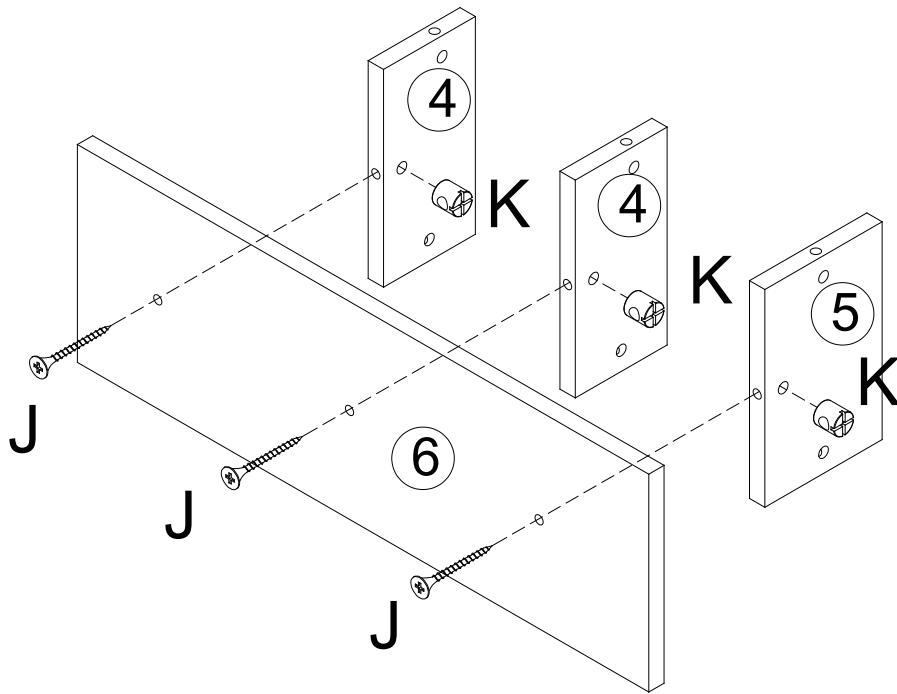

Step 10

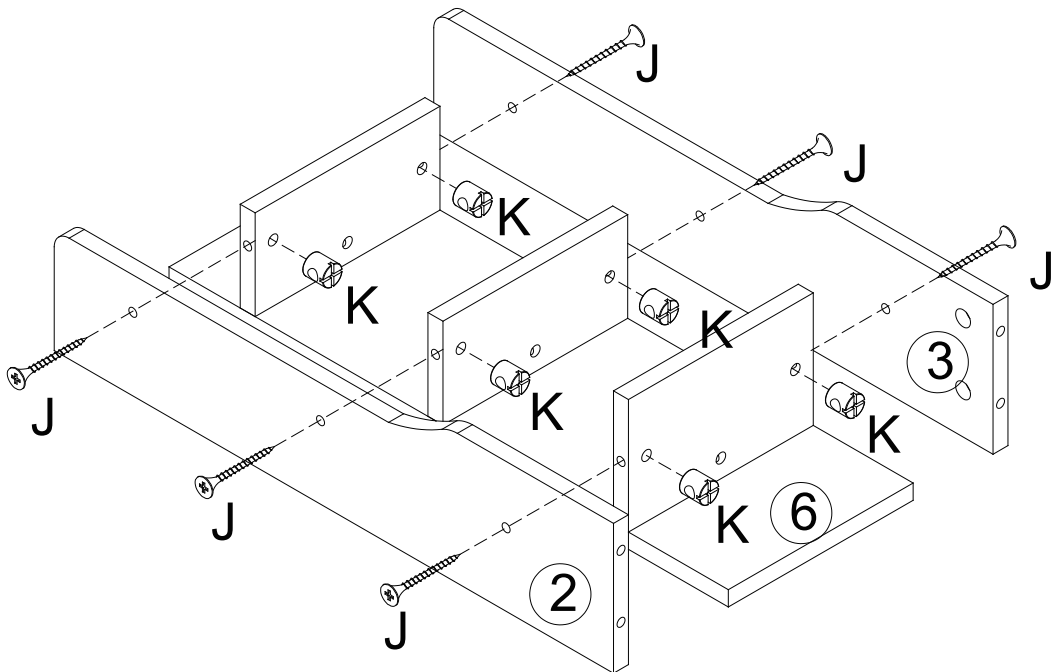

Step 11

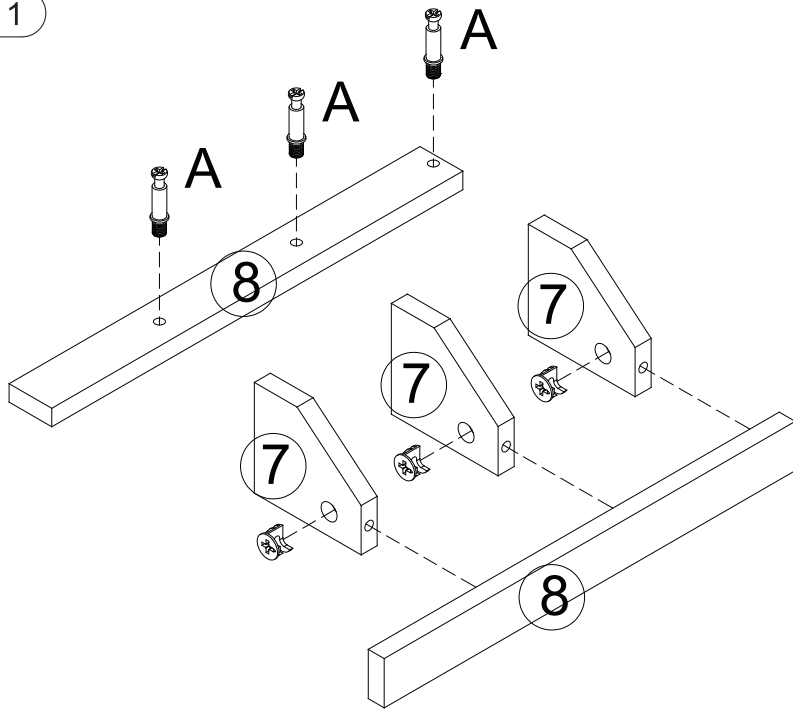

Step 12

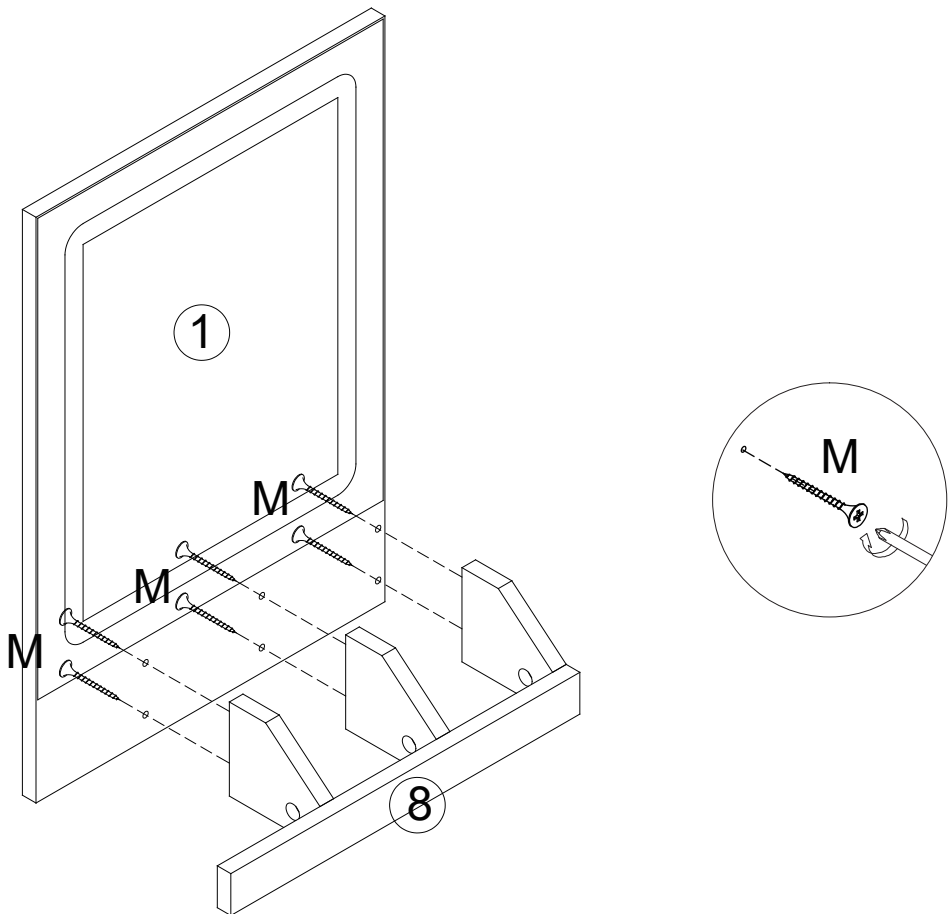

Step 13

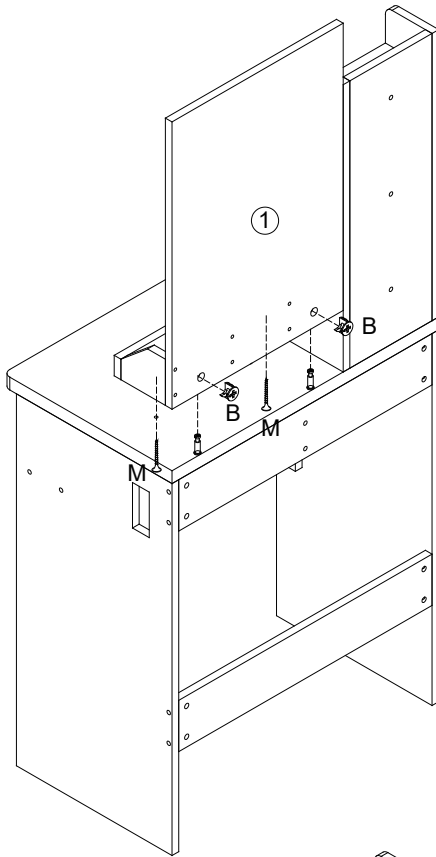

Step 14

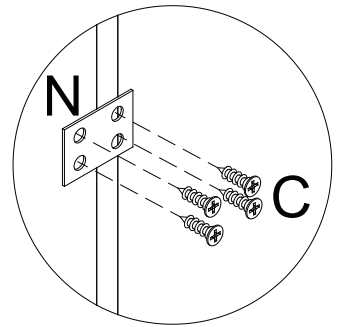
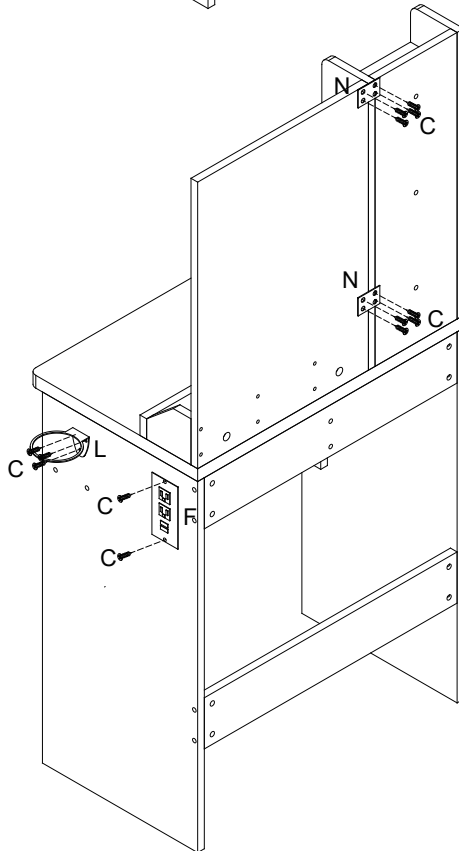

Step 15

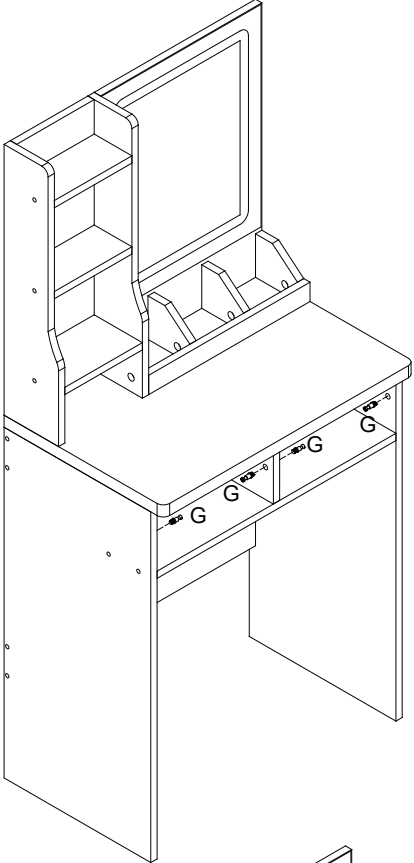

Step 16

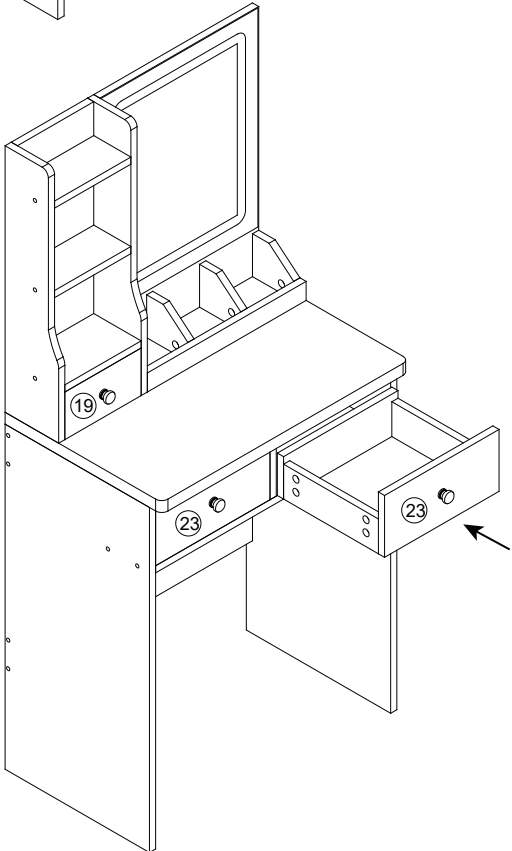

Step 17

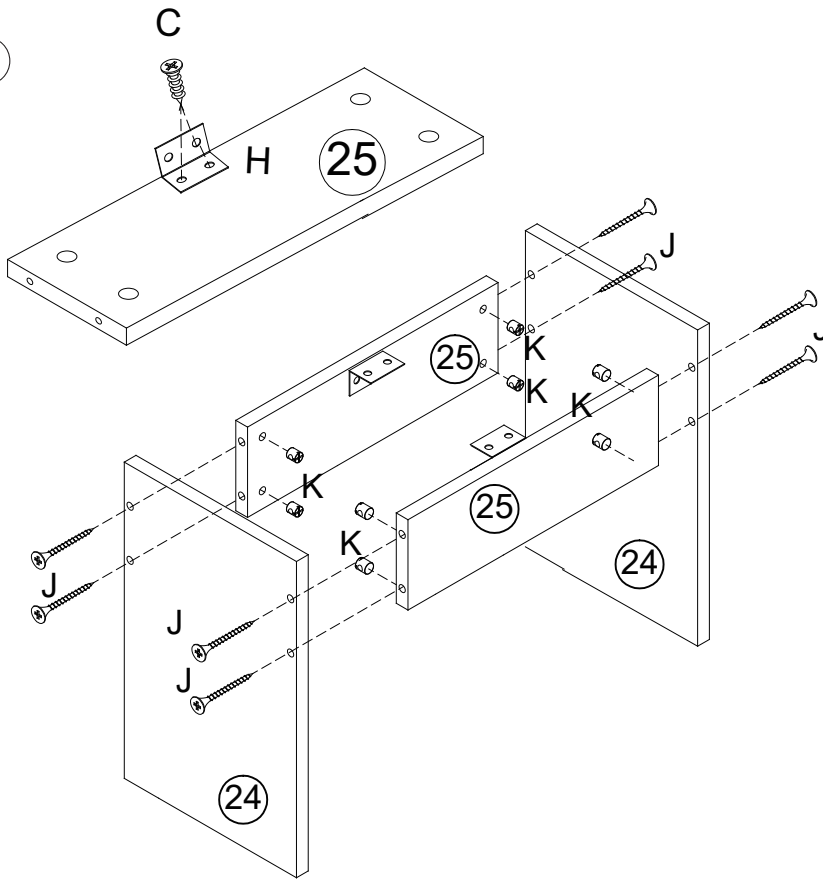

Step 18

