

# Ottoman

STEP 1  
Rotate legs to down position

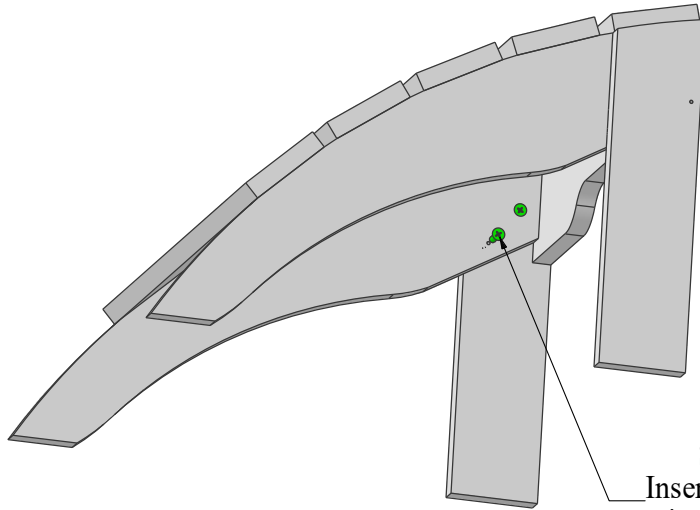

STEP 2  
Insert (1) 1-1/4" screw to the  
inside of both front legs

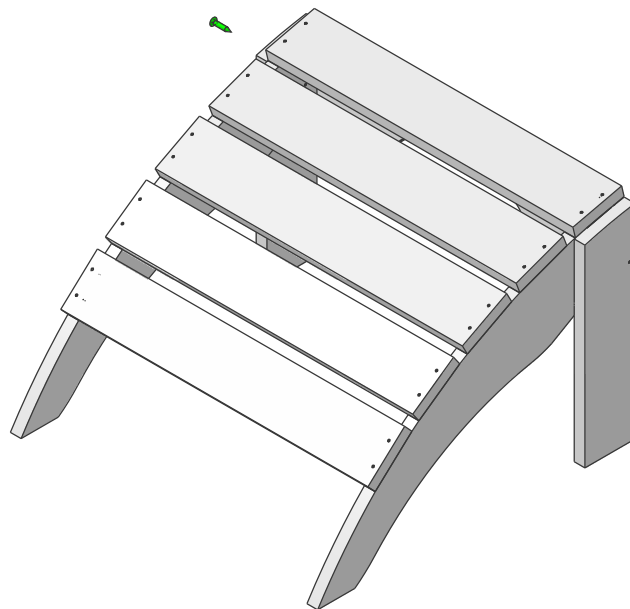

STEP 3  
Insert (1) 1-1/4" screw to the  
outside of both front legs

Tools needed:  
Phillips screwdriver  
(4) - 1-1/4" Phillips wood screws (included)