

NOTICE

* Please make sure that you have all parts indicated and they are in good condition before you begin assembly of this item. Refer to part list and hardware list below for guidance.

* This item should be assembled on a soft surface to prevent scratching the finish during assembly.

* This item may require periodic tightening.

* If you are having difficulty, our friendly Customer Care team is always here to help.

PREPARATION

* Before beginning assembly of product, make sure all parts are present.

Compare parts with part contents list and hardware contents list.

* If any part is missing or damaged, do not attempt to assemble the product





* Estimated assembly time : **15 minutes.**

* Tools required for assembly (included) : **Allen key**

CARE AND MAINTENANCE

Always use felt pads under all articles to prevent discoloration or softening of the lacquer. Plastic and rubber bases on items can discolor wood. Wipe up spill immediately and avoid common hazards such as hot dishes, harsh solvents and abrasives. Cleaning should be done with a soft lint free cotton cloth dampened with water or furniture polish. On highly used surfaces we recommend applying a quality paste wax which should be used on a regular basis to provide additional protection from scratches and spills. How often you apply the wax depends on how much wear the furniture receives.

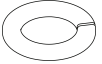
Part List and Hardware List

PIECE	DESCRIPTION	PICTURE	QUANTITY
A	Table Top		1x
B	Table Leg		4x
HW 1	Jcbb Bolt M8 x 0.5 x 70mm		8x
HW 2	Spring Washer 8mm		8x
HW 3	Flat Washer 8mm		8x
HW 4	Allen key		1x

Product Dimensions : 70.86" (59.05") W x 31.49" D x 29.13" H

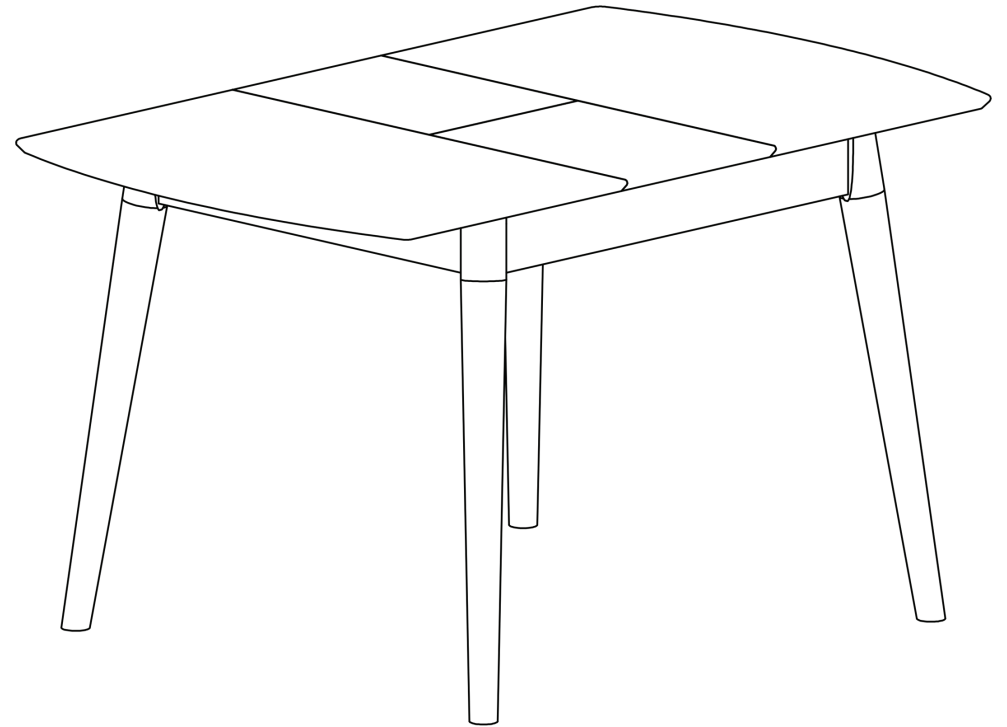

Weight capacity - 248 LBS

Warning : Do not stand on table.

Warning : Do not over torque bolts.

PREPARATION

- * Before beginning assembly of product, make sure all parts are present. Compare parts with part contents list and hardware contents list.
- * If any part is missing or damaged, do not attempt to assemble the product.
- * Estimated assembly time : 15 minutes
- * Tools required for assembly (included) : Allen key
- * If you are having difficulty, our friendly Customer Care team is always here to help.

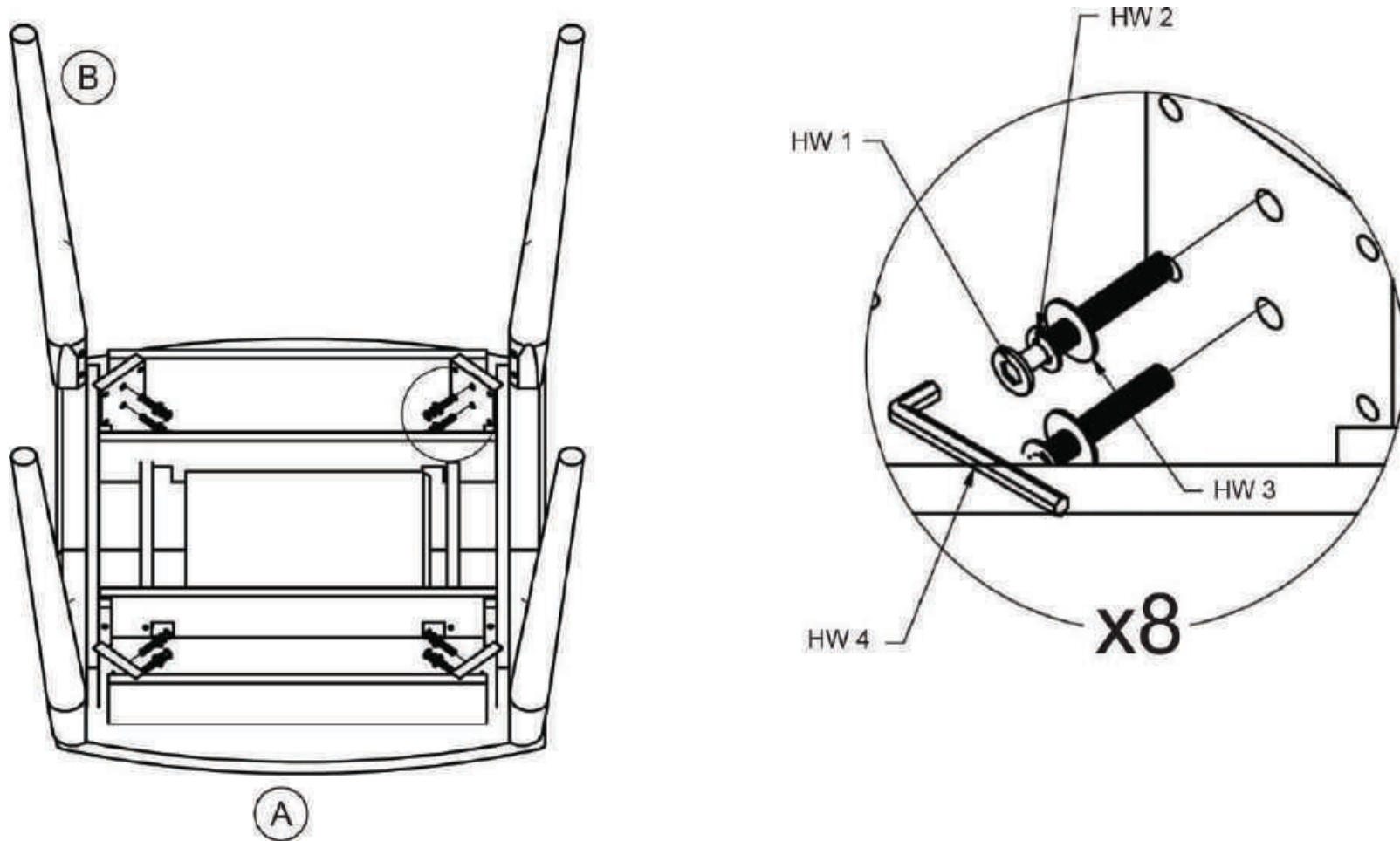

Step 1 : Place the table leg(B) in position and screw in the bolts (HW1). Put the washer (HW2,HW3) on the bolts (HW1) in the order shown in the picture.

HOW TO USE

Step 1
Unlock the table lock and glide at both side.

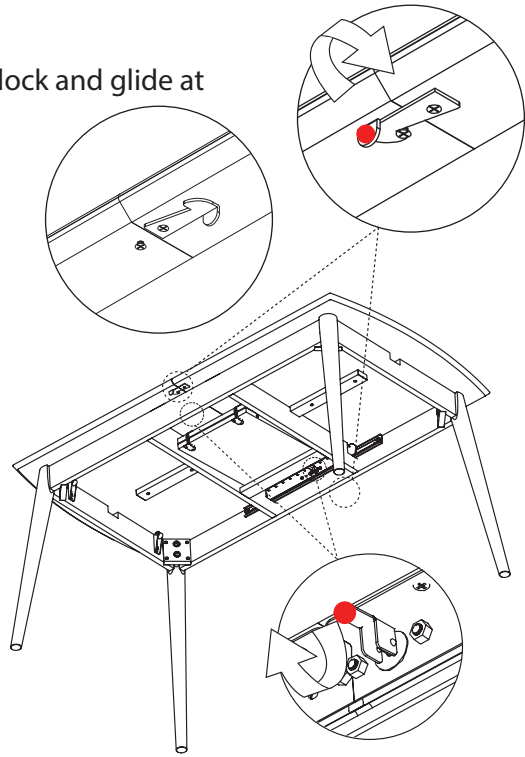

Step 2

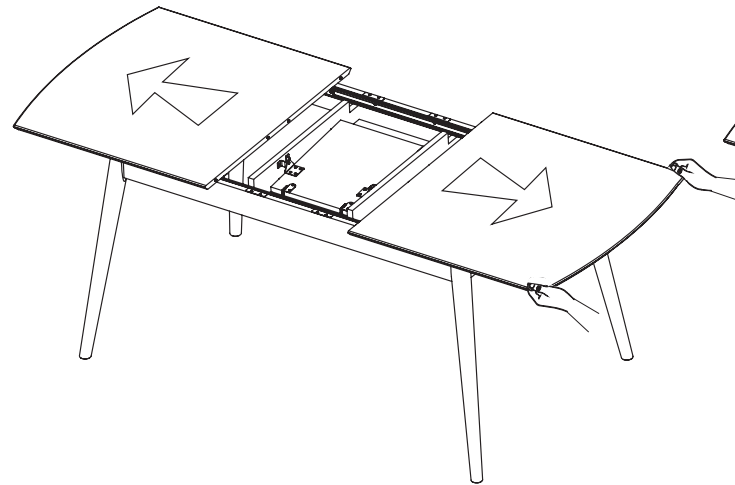

Step 3

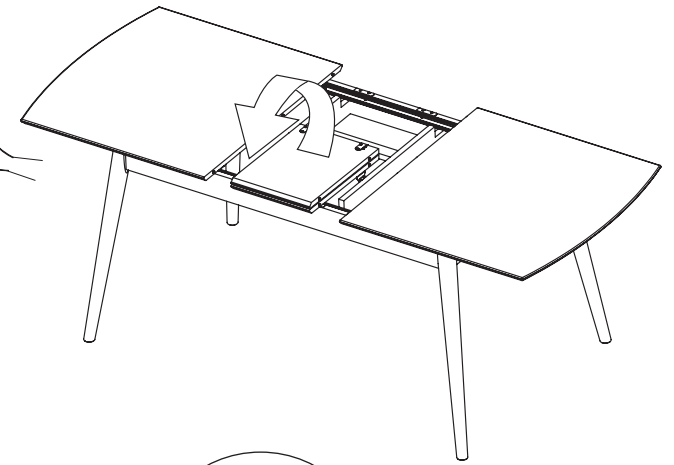

Step 4

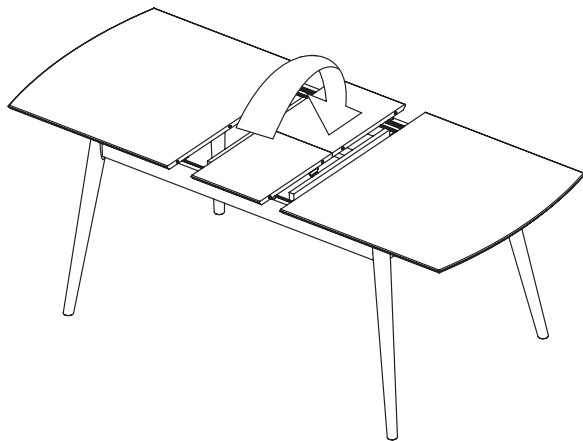

Step 5

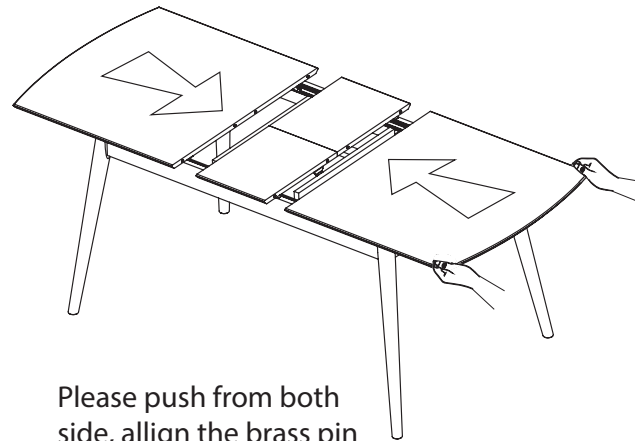

Please push from both side, align the brass pin with the hole. (same for both, open and close)

Step 6

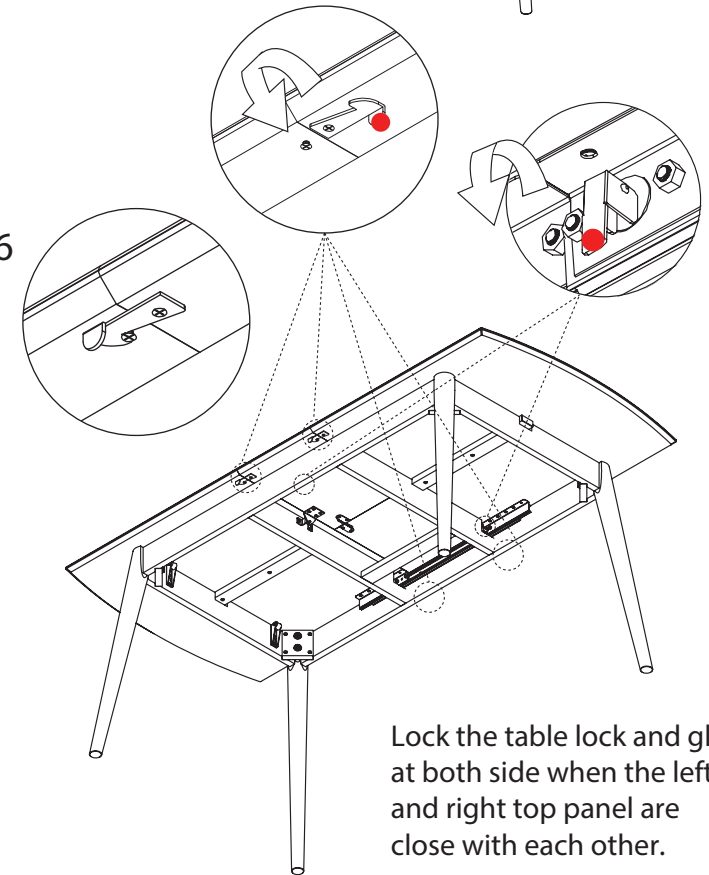

Lock the table lock and glide at both side when the left and right top panel are close with each other.