

assembly guide



Valued Customer,

We design and carefully manufacture our products for our customers, We wish that our customers to have fun while they are doing their new furniture

The product you just purchased was subjected to all sorts of tests and controls before sending out to you.

Hope you enjoy your new furniture!!!

Before starting, please check all components and accessories according to the provided list. If you purchased more than one product, to prevent confusion, be sure that you completed the first product, then start the next one. Please make sure that you select correct numbered part and use specific connector to assemble. We do not recommend any modification or rotation in assembly. Please follow the manual carefully.

Furniture parts are going to several manufacturing procedures. During this process, parts can have little dust or marks. Please clean the parts with damp cloth before assembly to get the best result. Usual cleaning would be suffice.



Although all products are carefully manufactured and packed, sometimes we experience damage during transportation. In such cases, please check the damaged part, note the part number written on the part and do not hesitate to contact us

Do not use your furniture for out of purposes. If you would like to use it out of purpose or would like to do some modification or rotation, please contact us for more details.

Please do not expose your furniture with excessive heat, cold and humidity because product can be affected negatively.

before you start

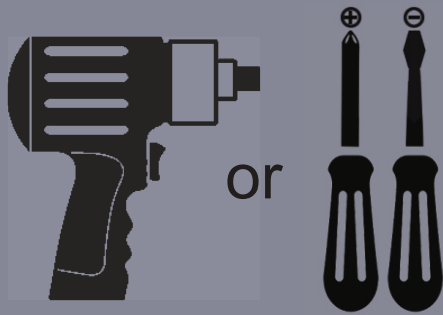

Get required installation tools prepared.

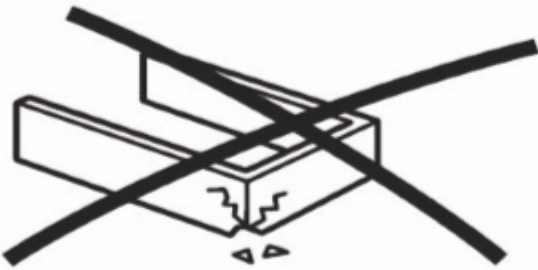

Do not install the product on rough surfaces.

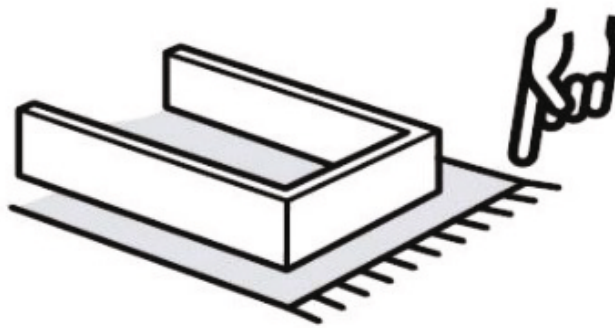



Get help from someone else!

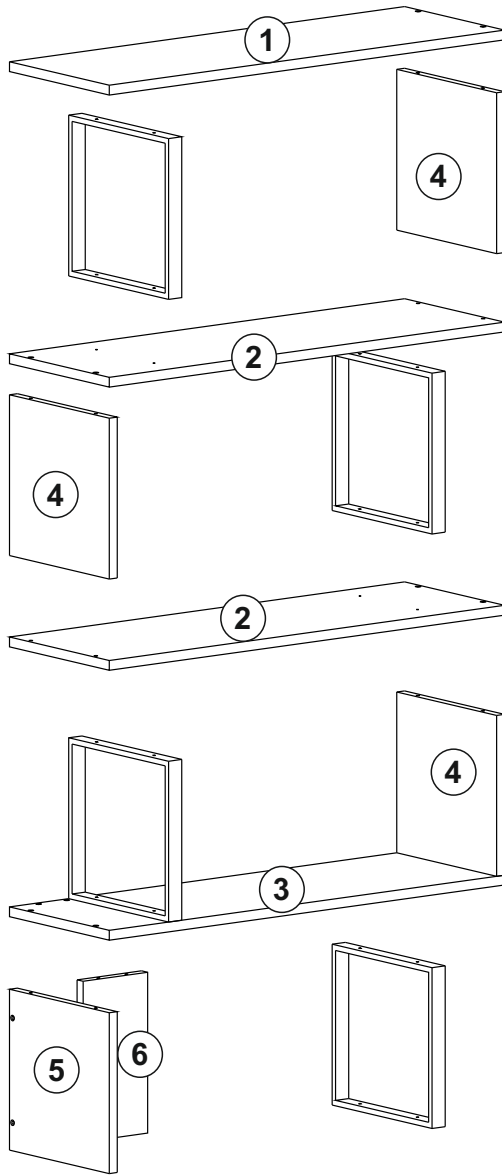

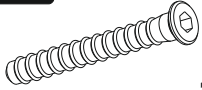

Part1	1x
Part2	2x
Part3	1x
Part4	3x
Part5	1x
Part6	1x
TOTAL	9x

A09 3.5x25 mm screw  14x	A13 50 mm screw  18x	A06 12 mm sticker  18x
---	---	---

1

step a

*Please attach the pieces #5 and #3 together as shown below

*Now screw the A13(50 mm screw) with the help of a screwdriver clockwise direction

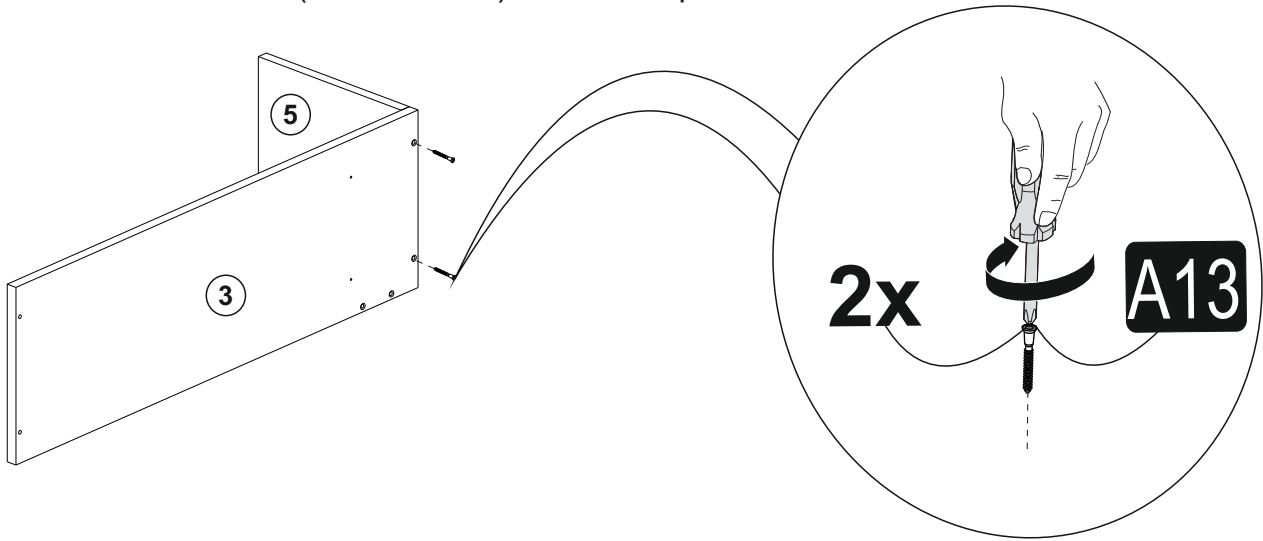

2

step b

*Please put the one of metal pieces on the piece #3 as shown below

*Now screw the A09(3.5x25 mm screw) with the help of a screwdriver clockwise direction

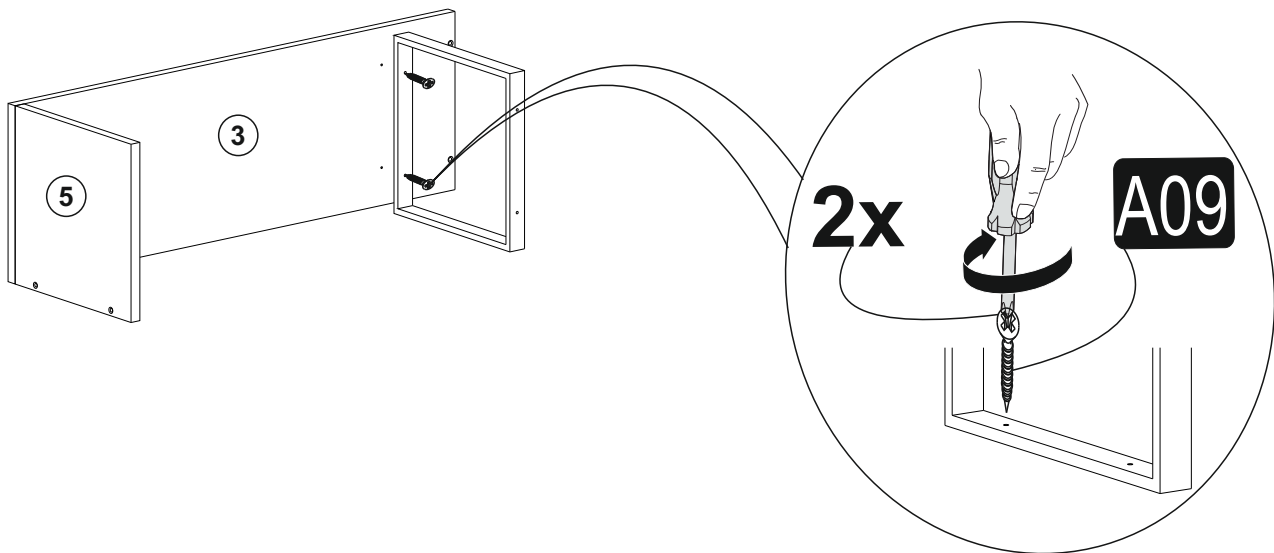

3

step c

*Please attach the piece #6 to the pieces #3 and #5 as shown below

*Now screw the A13(50 mm screw) with the help of a screwdriver clockwise direction

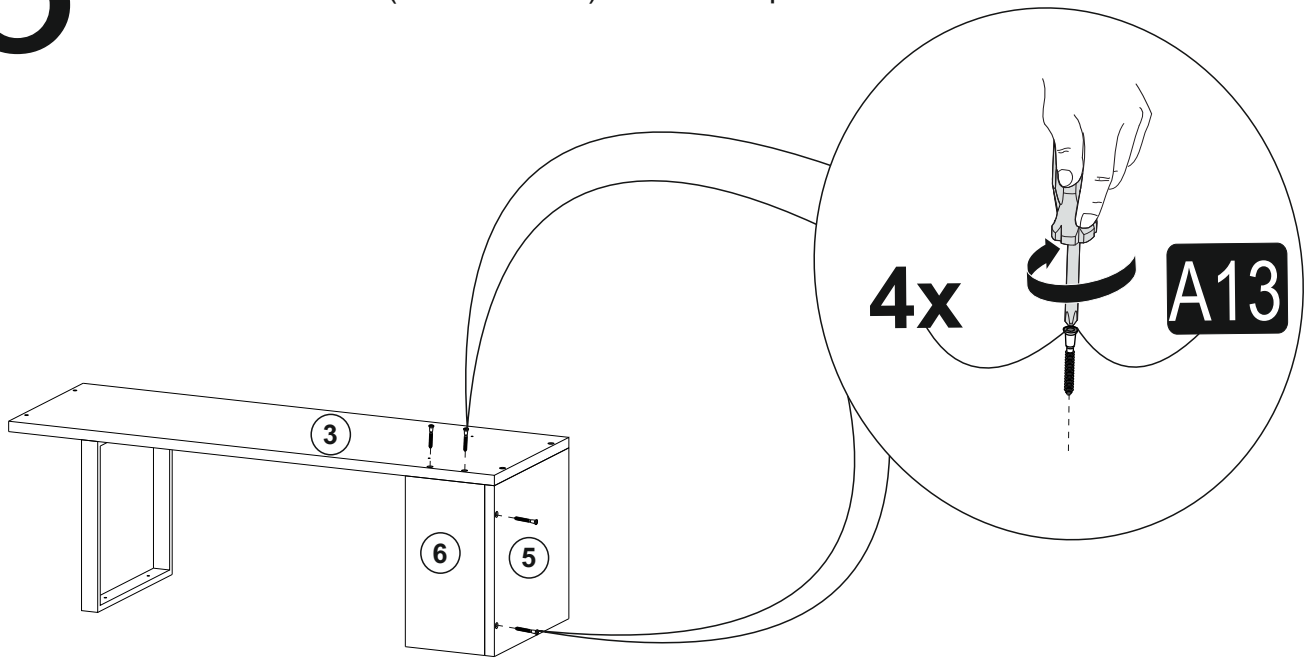

4

step d

*Please put the one of metal pieces on the piece #3 as shown below

*Then screw the A09(3.5x25 mm screw) with the help of a screwdriver clockwise direction

*Please put the piece #4 on the piece #3 together as shown below

*Now screw the A13(50 mm screw) with the help of a screwdriver clockwise direction

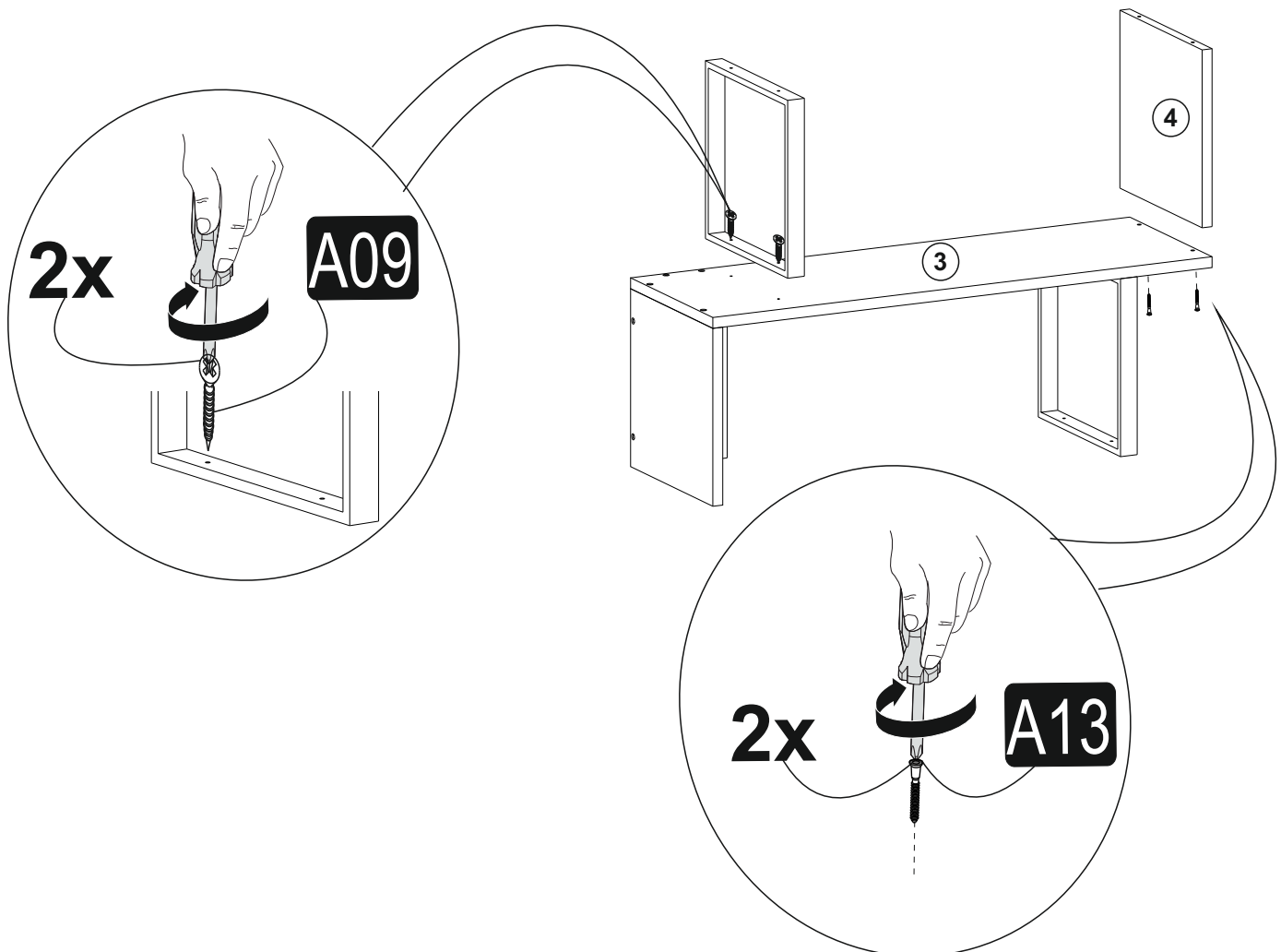

5 step e

*Please put the piece #2 on the metal piece and piece #4 as shown below.

*Then screw the A09(3.5x25 mm screw) on the metal piece with the help of a screwdriver clockwise direction

*Please put the piece #4 and metal piece on the piece #2 as shown below

*Now screw the A13(50 mm screw) on both pieces #4 with the help of a screwdriver clockwise direction

*Then screw the A09(3.5x25 mm screw) on the metal piece with the help of a screwdriver clockwise direction

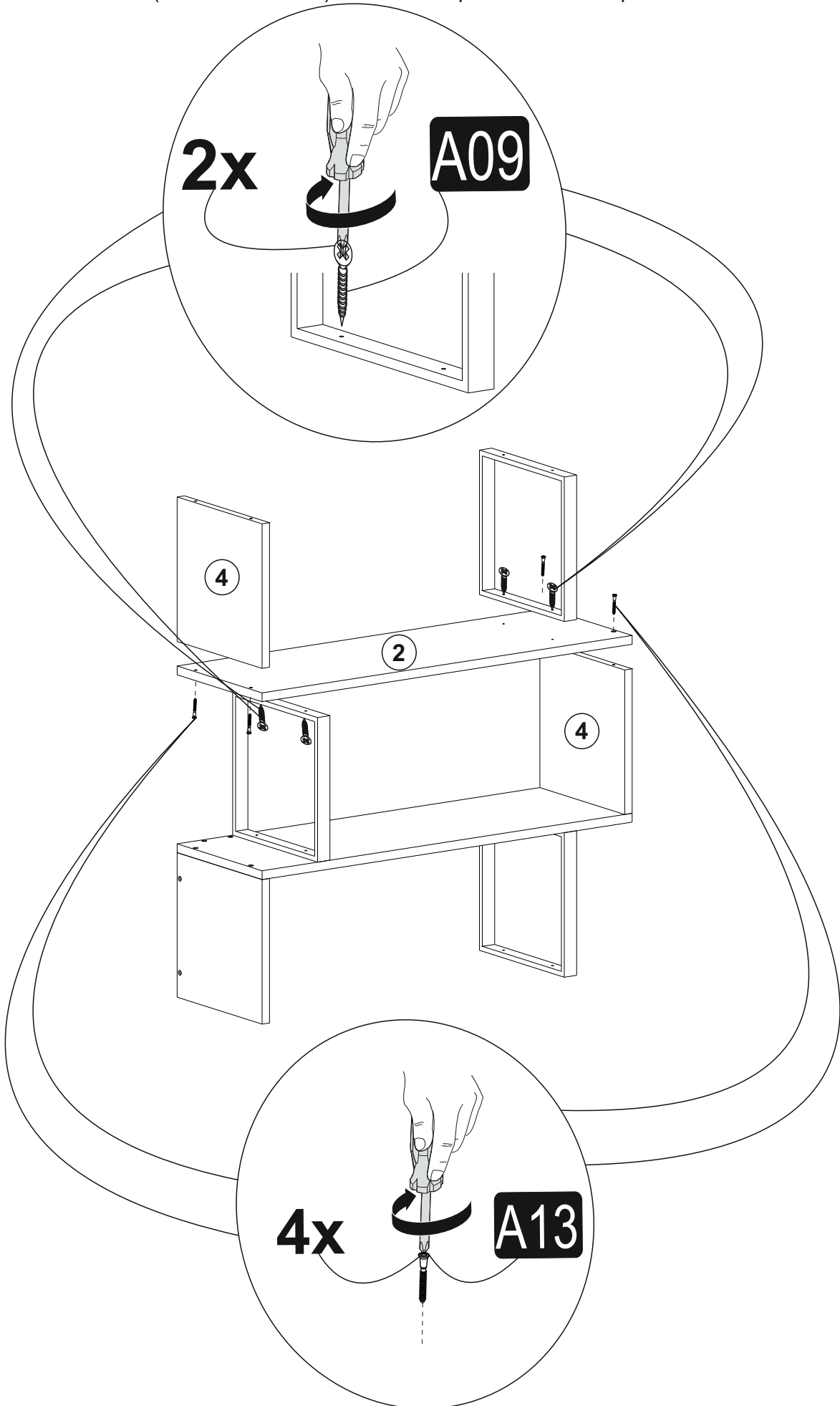

6 step f

*Please put the piece #2 on the metal piece and piece #4 as shown below.

*Then screw the A09(3.5x25 mm screw) with the help of a screwdriver clockwise direction as shown below

*Now screw the A13(50 mm screw) with the help of a screwdriver clockwise direction as shown below

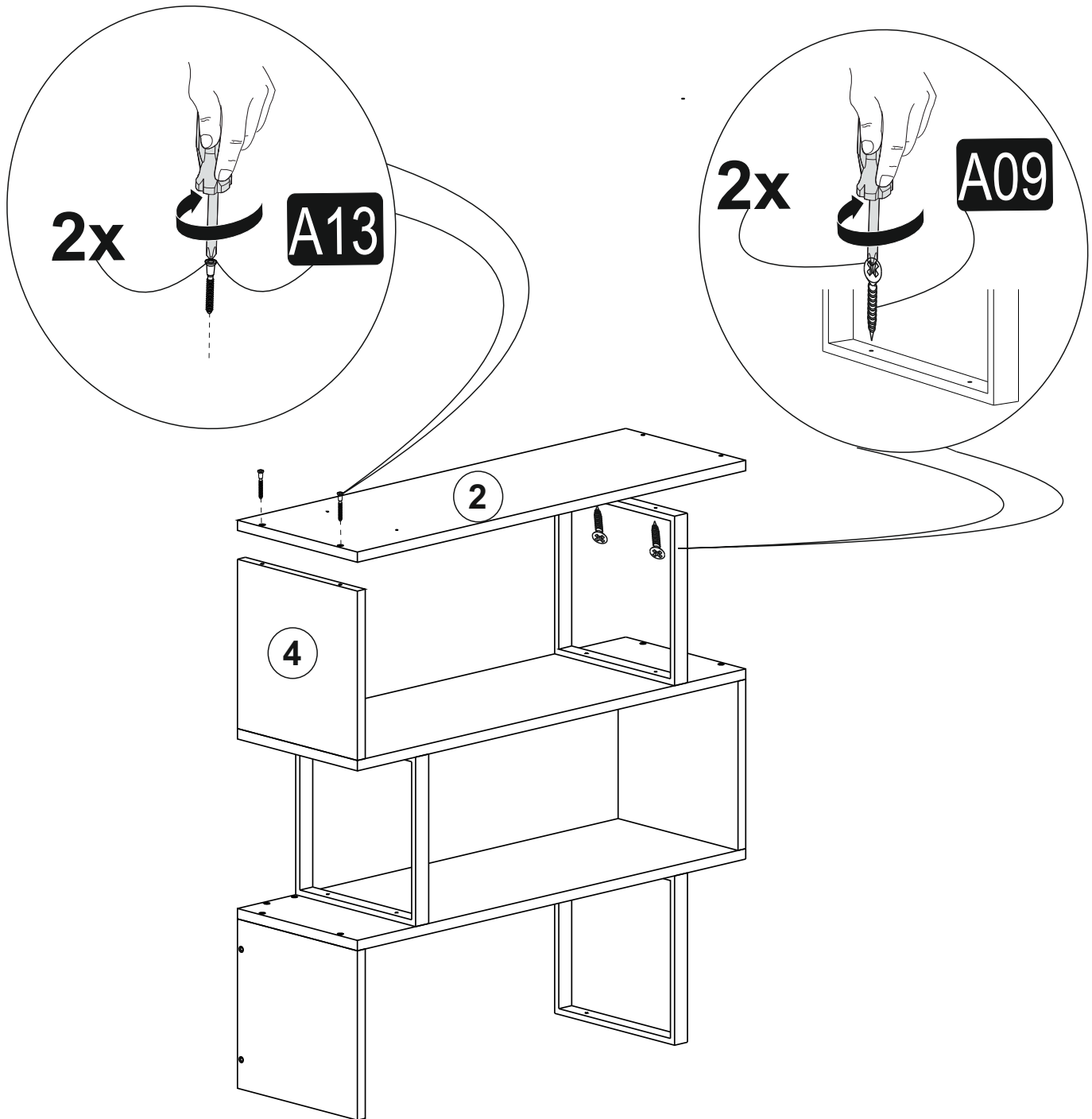

7 step g

*Please put the metal piece and piece #4 on the piece #2 as shown below.

*Then screw the A09(3.5x25 mm screw) with the help of a screwdriver clockwise direction as shown below

*Now screw the A13(50 mm screw) with the help of a screwdriver clockwise direction as shown below

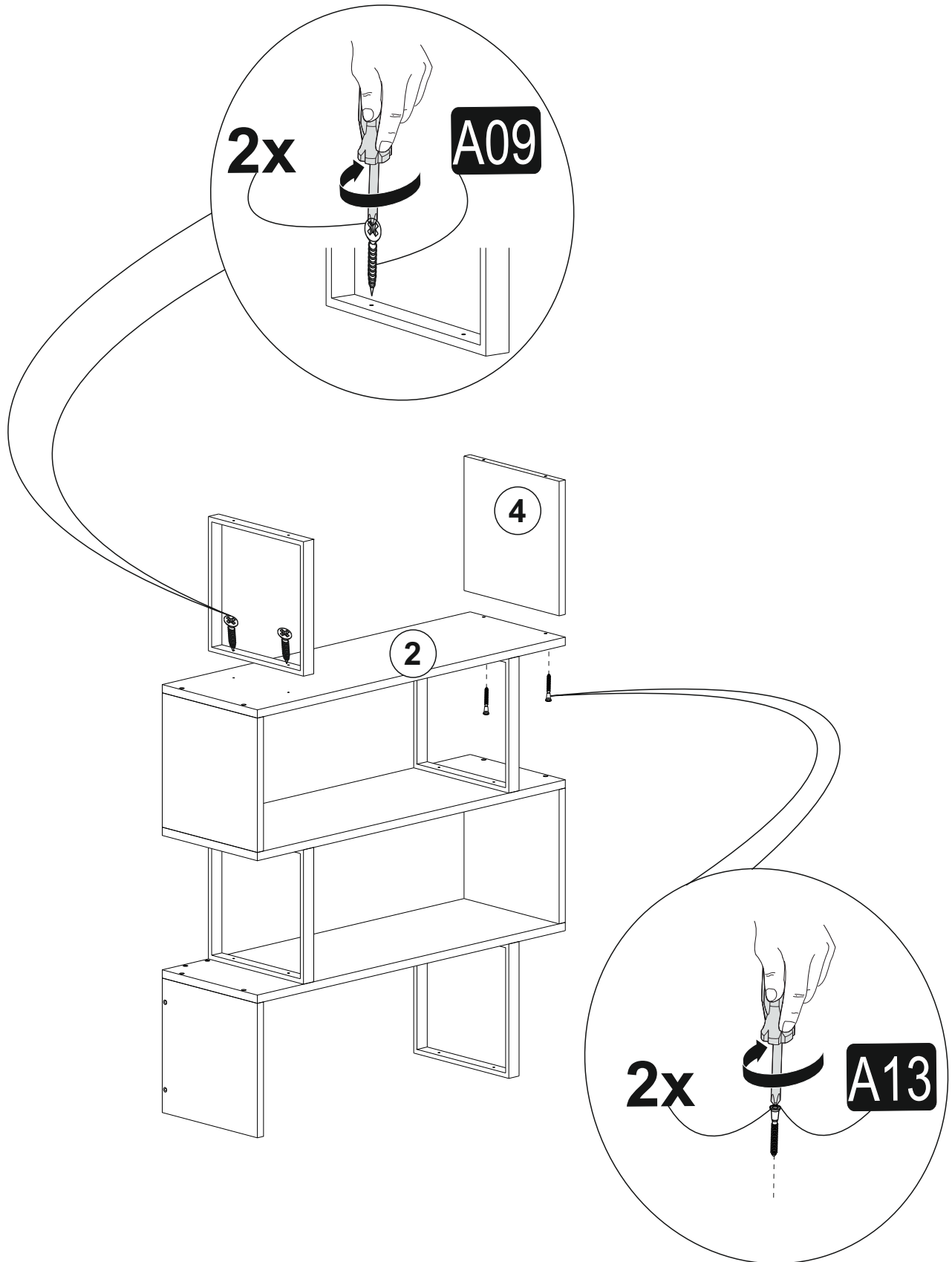

8

step h

*Please put the piece #1 on the metal piece and piece #4 as shown below.

*Then screw the A09(3.5x25 mm screw) with the help of a screwdriver clockwise direction as shown below

*Now screw the A13(50 mm screw) with the help of a screwdriver clockwise direction as shown below

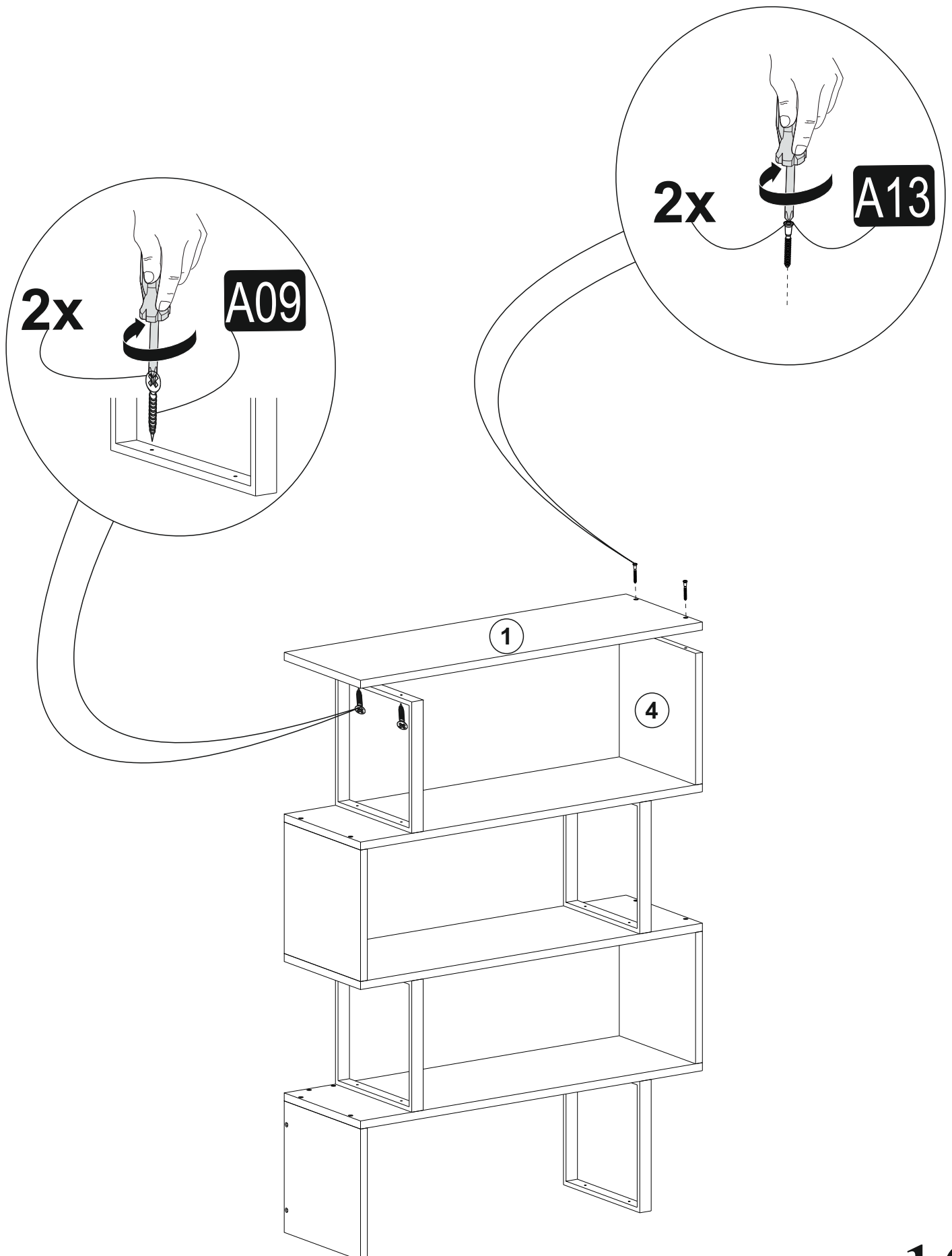

9 step j

*For the best appearance of your furniture please place all A06(12 mm sticker) onto the A13 (50 mm screw)

