

5 PCS CONVERSATION SET
ASSEMBLY MANUAL

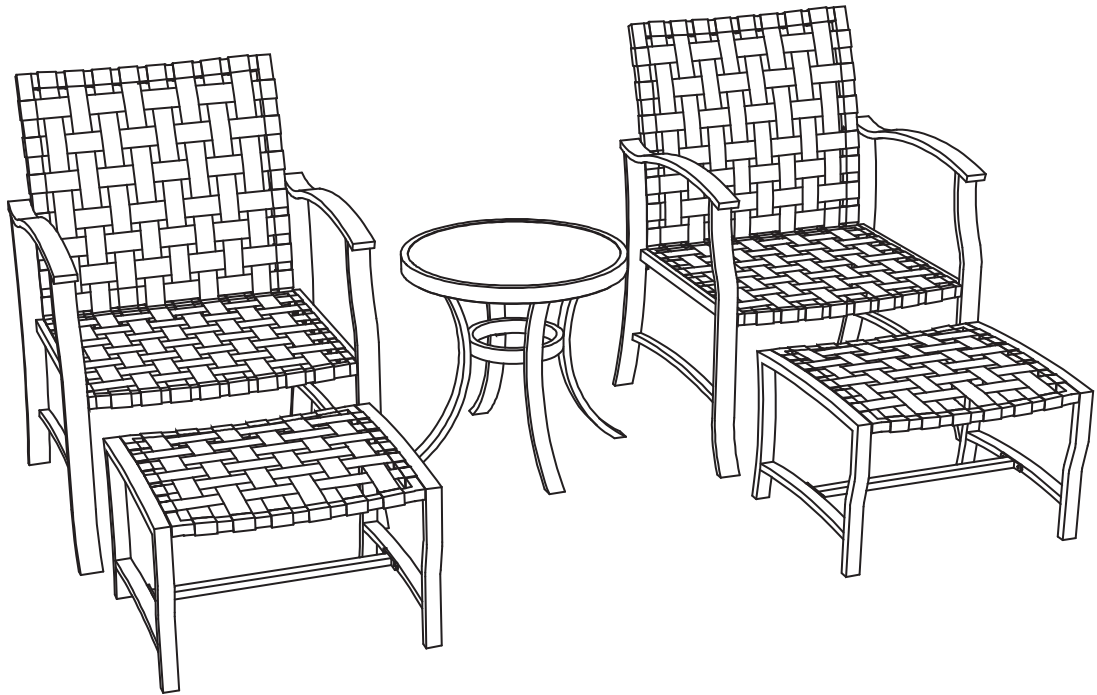

ASSEMBLY INSTRUCTION

5 PCS CONVERSATION SET

NOTE: DO NOT FULLY TIGHTEN BOLTS UNTIL ALL STEPS ARE COMPLETED.

USE THE ORIGINAL CARTON AS A SOFT WORKING SURFACE IN ORDER NOT TO DAMAGE THE PRODUCT.

Step 1

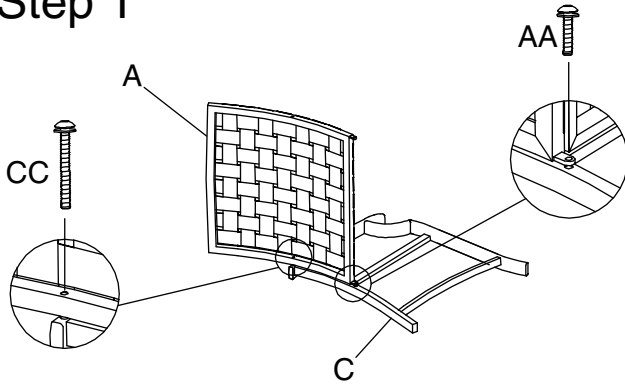

Step 1: Place the left arm (C) on the carton and attach the back (A) by lining up the corresponding holes on the left arm (C) and the back (A). Insert M6x20 bolt & washer (AA) and M6x40 bolt & washer (CC), and loosely tighten with the Allen Wrench (DD). Do not over tighten.

Step 2

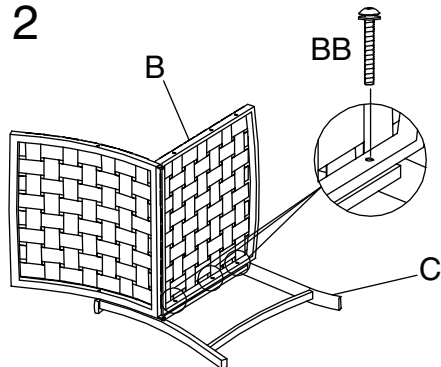





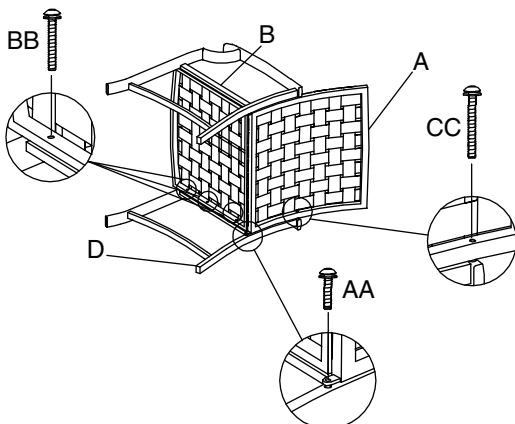

Step 2: Attach the seat (B) to the assembled part. Line up the corresponding holes on the assembled part and the seat (B), and insert M6x30 bolt & washer (BB), loosely tighten with the Allen Wrench (DD). Do not over tighten.

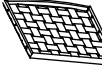
Step 3



DO THIS TWO TIMES

PART NO.	PICTURE	DESCRIPTION	QTY
A		Back	1x2
B		Seat	1x2
C		Left Arm	1x2
D		Right Arm	1x2
AA		M6x20 Bolt & Washer	2x2
BB		M6x30 Bolt & Washer	6x2
CC		M6x40 Bolt & Washer	2x2
DD		Allen Wrench	2

Step 3: Place the left arm (D) on the carton, and attach the assembled part to the left arm (D). Line up the corresponding holes on the assembled part and the left arm (D), and insert the bolts M6x20 & washer (AA), M6x30 & washer (BB) and M6x40 & washer (CC), loosely tighten with the Allen Wrench (DD). Do not over tighten.

Step 4

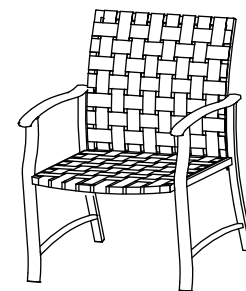

Step 4: After all the bolts are inserted, fully tighten all the bolts. Turn the chair right side up. Ensure all the connections are secure before use.

5 PCS CONVERSATION SET - OTTOMAN

NOTE: Do NOT COMPLETELY TIGHTEN BOLTS UNTIL ALL STEPS ARE COMPLETED.

USE THE ORIGINAL CARTON AS A SOFT WORKING SURFACE IN ORDER NOT TO DAMAGE THE PRODUCT.

DO THIS TWO TIMES

Step 1

Step 1: Place the right arm (D) on the carton and attach the seat (A) and supporting tube (B) by lining up the corresponding holes on the seat (A), supporting tube (B) and the right arm (D). Insert the M6x15 bolt & washer (AA) and M6x35 bolt & washer (BB), and loosely tighten with the Allen Wrench (CC).

Do not over tighten.

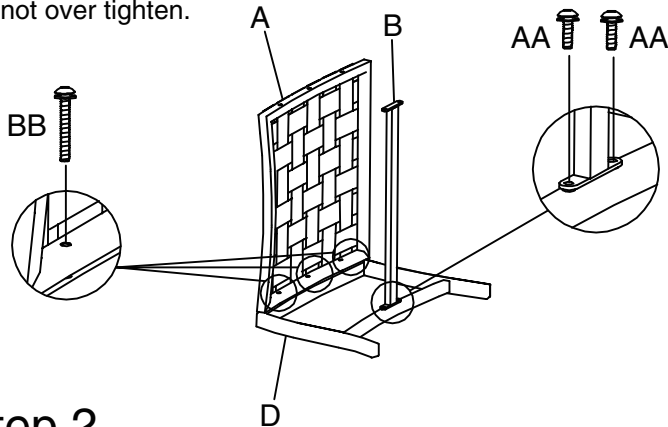

Step 2

Step 2: Place the left arm (C) on the carton and attach the assembled part to the left arm (C). Line up the corresponding holes on the assembled part and the left arm (C), and insert the M6x15 bolt & washer (AA) and M6x35 bolt & washer (BB), loosely tighten with the Allen Wrench (CC).

Do not over tighten.

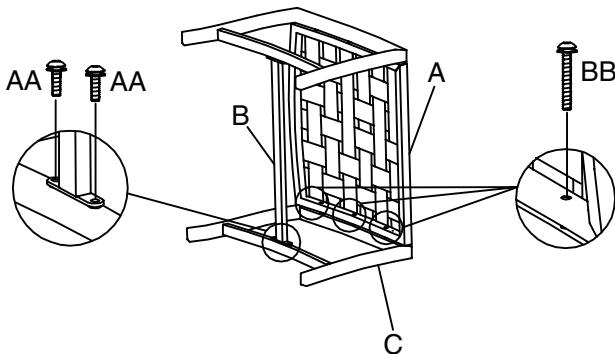

Step 3

Step 3: After all the bolts are inserted, fully tighten all the bolts with Allen Wrench (CC).

Turn the footrest right side up.

Ensure all the connections are secure before use.

PART NO.	PICTURE	DESCRIPTION	QTY
A		Back	1x2
B		Supporting Tube	1x2
C		Left Arm	1x2
D		Right Arm	1x2
AA		M6x15 Bolt & Washer	4x2
BB		M6x35 Bolt & Washer	6x2
CC		Allen Wrench	use chair's

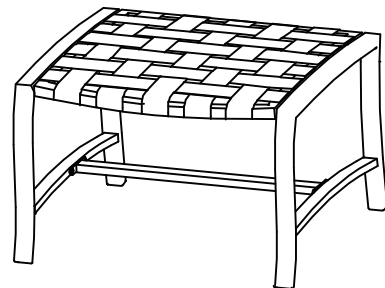

5 PCS CONVERSATION SET- COFFEE TABLE

NOTE: DO NOT FULLY TIGHTEN BOLTS UNTIL ALL STEPS ARE COMPLETED.





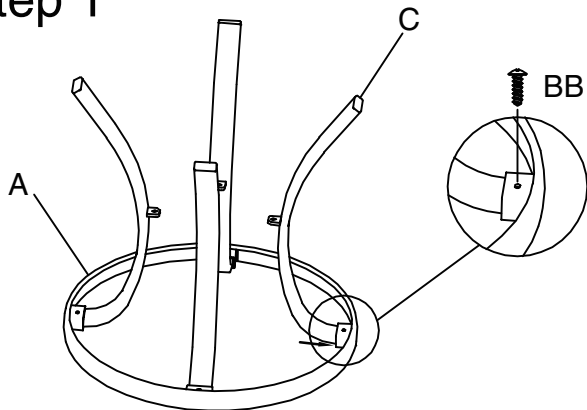

USE THE ORIGINAL CARTON AS A SOFT WORKING SURFACE IN ORDER NOT TO DAMAGE THE PRODUCT.

THE WRENCH FOR THE SELF-DRILLING SCREW IS NOT INCLUDED.

Step 1



Step 1: Place the table top (A) on the carton. Insert the table legs (C) into the corresponding holes on the corners of the table top (A). Line up the corresponding holes on the table top (A) and the table legs (C), and insert the self-drilling screw (BB). Do not over tighten.

PART NO.	PICTURE	DESCRIPTION	QTY
A		Table Top	1
B		Connecting Ring	1
C		Table Leg	4
AA		M6x15 Bolt & Washer	4
BB		Self- drilling Screw	4
CC		Allen Wrench	use chair's

Step 2

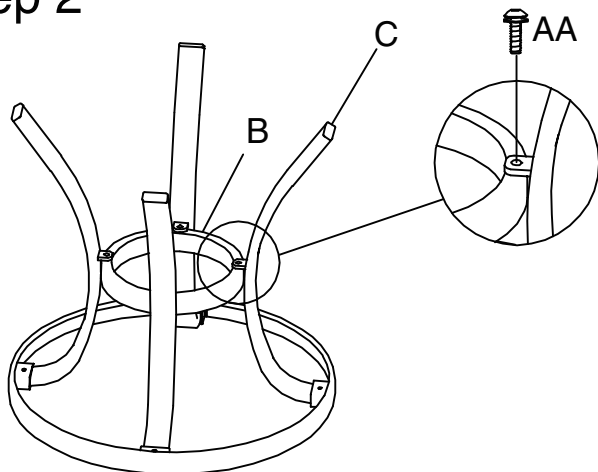

Step 2: Place the connecting ring (B) between the four table legs (C). Line up the corresponding holes on the table legs (C) and the connecting ring (B), and insert M6x15 bolt & washer (AA), loosely tighten with the Allen Wrench (CC). Do not over tighten.

Step 3

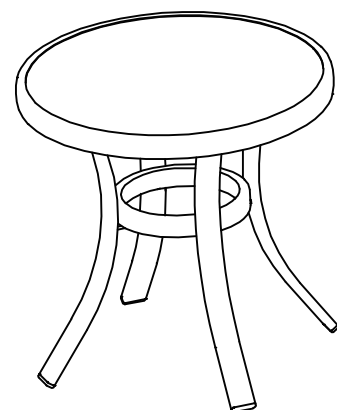

Step 3: After all the bolts are inserted, fully tighten all the bolts. Turn the table right side up, and check alignment of the table legs and adjust as needed. Ensure all the connections are secure before use.