

ASSEMBLY INSTRUCTION

Bed- Q / F

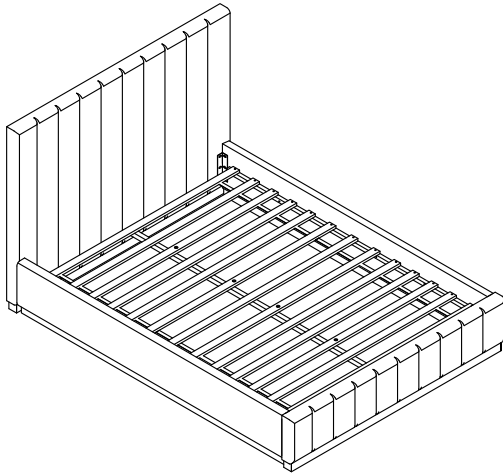

+ Do Not Use Power Tools



+Suggested Adults

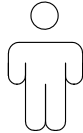

NOTE:

- 1 Read instructions cover to cover.
- 2 Save all packaging until assembly is completed.

1 IMPORTANT SAFETY INFORMATION

Do not assemble the product if any of the following parts arrived damaged:

- Part#1 -Headboard Part#7 -Center leg
- Part#2 -Footboard
- Part#3 -Wood strip for Side rail
- Part#4 -Center slat support
- Part#5 -Side rail Part#8 -Wood Block on
- Part#6 -Slats Headboard & Footboard

Do not assemble if any of the following Hardware parts are missing:

- Part#B,E, -Bolt Part#D, -Lock washer
- Part#A, -Allen Key Part#G -Metal bracket
- Part#C,H -Flat washer Part#F -screw

2 IMPORTANT SAFETY INFORMATION

Assembly Step if loosening persists, please make sure to tighten all the bolts periodically, or use a thread locker adhesive.

+Parts Included

① Headboard (1pc)

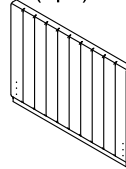

② Footboard (1pc)

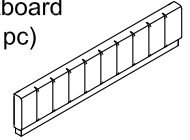

③ Wood strip for Side rail (2pcs)

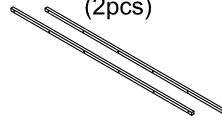

④ Center slat support (1pc)

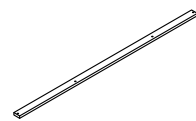

⑤ Side rail (2pcs)

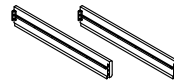

⑥ Slats (13pcs)

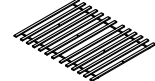

⑦ Center leg (4pcs)



⑧ Wood Block on Headboard & Footboard (2pcs)



+Hardware Included

A Ø5/16" (1pc)



B Ø5/16"×1" (24pcs)

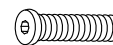

C Ø5/16" (24pcs)



D Ø5/16" (42pcs)



E Ø1/4" *2 3/8" (18pcs)



F #8*30mm (28pcs)



G Metal bracket (4pcs)

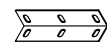

H Ø1/4" (18pcs)



ASSEMBLY INSTRUCTION

Bed- Q / F

1

Step 1. Attach Metal Bracket (G) to side rail (#5), Headboard (#1) and Footboard (#2) with Bolt (B), Lock washer (D) and Flat washer (C). Tighten with Allen Key (A).

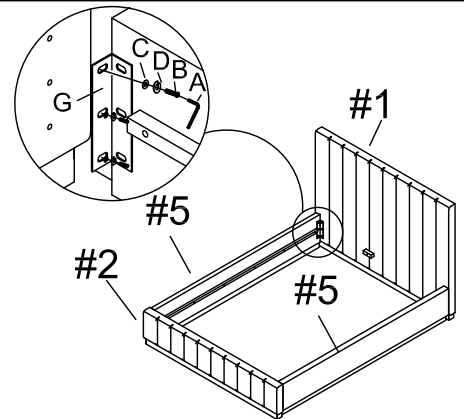

2

Step 2. Attach Wood strip for Side rail (#3) to side rail (#5) with Bolt (B), Lock washer (D) and Flat washer (C). Tighten with Allen Key (A).

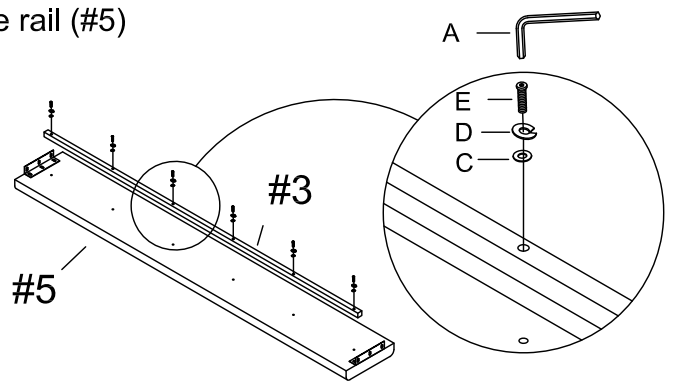

3

Step 3. Attach Wood Block on Headboard & Footboard (#8) to Headboard (#1) and Footboard (#2) with Bolt (E), Lock washer (D) and Flat washer (H). Tighten with Allen Key (A).

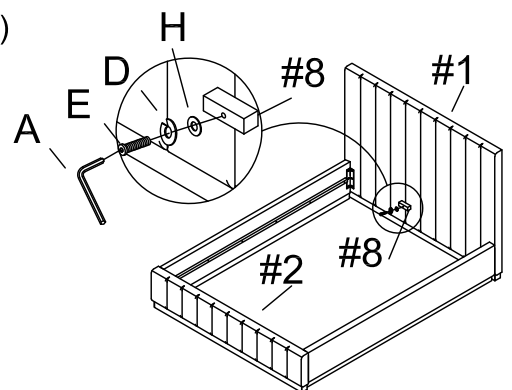

4

Step 4. Attach Center slat support (#4) to Headboard (#1) and Footboard (#2) with Screw (F).

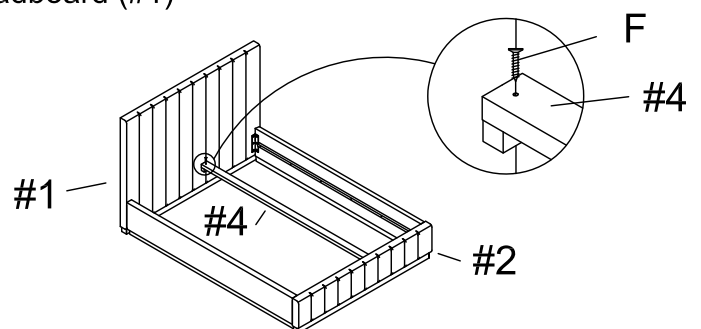

ASSEMBLY INSTRUCTION

Bed- Q / F

5

Step 5. Attach Center leg (#7) to Middle support rail (#4) and Slats (#6) with Bolt (E), Lock washer (D) and Flat washer (H). Tighten with Allen Key (A).

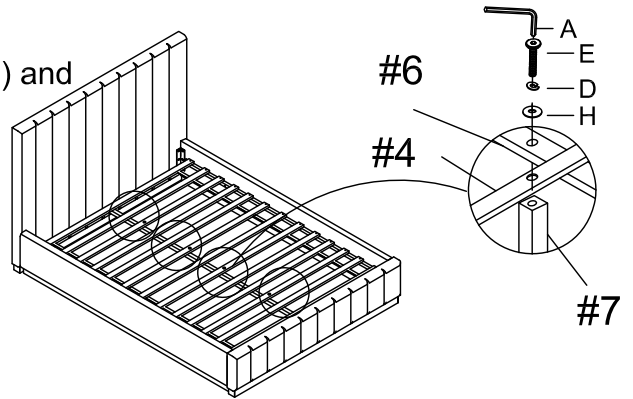

6

Step 6. Attach Slats (#6) to Side rail (#5) with Allen Screw (F).

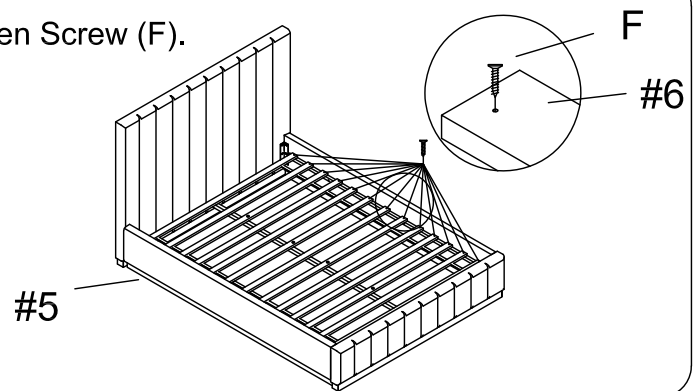

7

Assembly Complete.

