

# ASSEMBLY INSTRUCTIONS

---

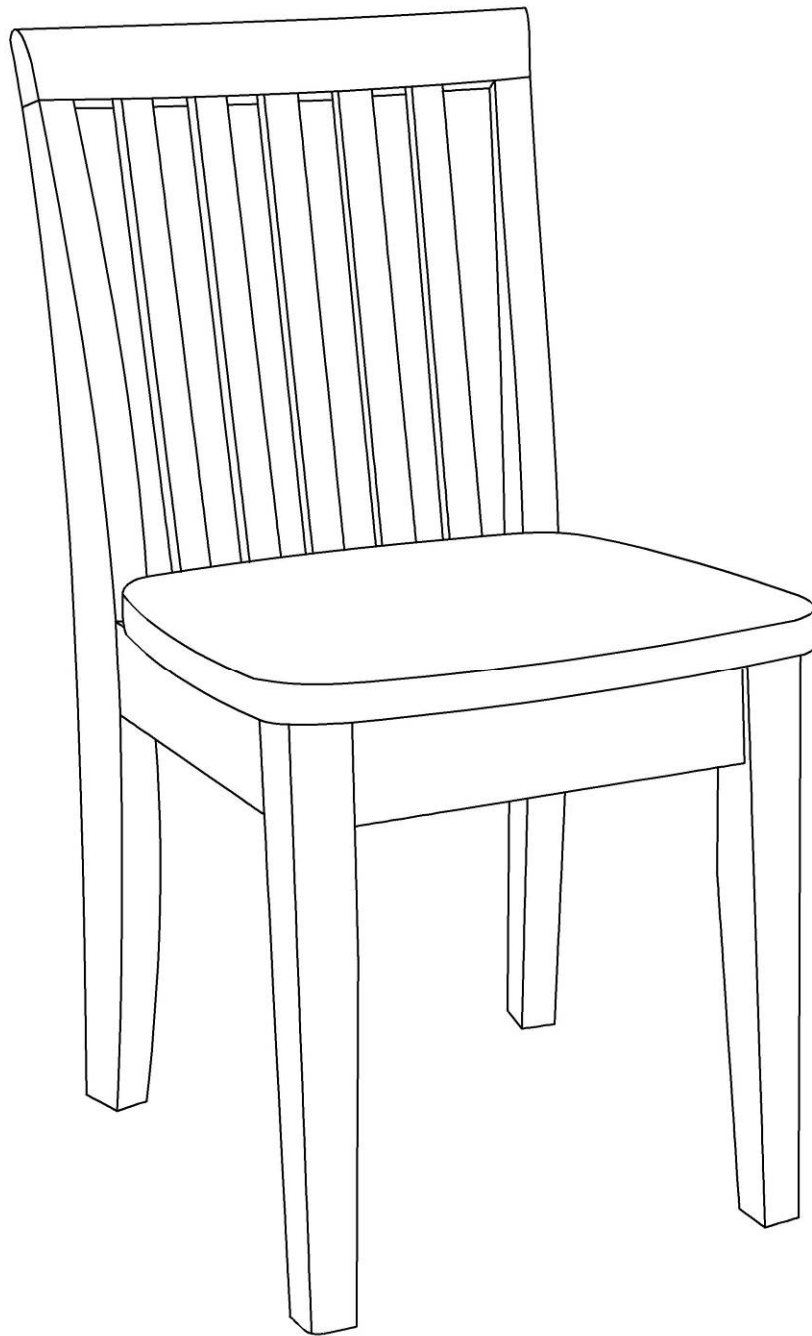

---

Description : CHAIR

Printed in Vietnam

## BEFORE ASSEMBLY

Thank you for purchasing this quality product. This product has been designed for easy assembly and constructed for durability. All parts were checked prior to packaging to insure quality. Prior to beginning assembly, however, make sure all parts and hardware are included and free of obvious defect. If a part is missing or defective, please contact the store where purchased. If hardware is missing, or you need help with assembly, please call toll free .

### IMPORTANT NOTE:

- Place all wooden parts on a clean and smooth surface such as a rug or carpet to avoid the parts from being scratched.
- Remove all wrapping material, including staples & packing straps before you start to assemble.
- DO NOT tighten all screws and bolts until completely assembled.
- Keep all hardware parts out of reach of children.



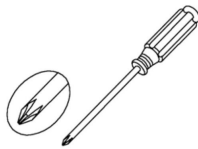

### ASSEMBLY TOOLS REQUIRED

NOT INCLUDED

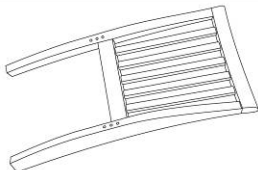

## PART LIST







When unpacking, please be careful not to discard any parts with the packaging. Before continuing, please make sure you have the following parts:

NO	Description	Qty	Sketch	NO	Description	Qty	Sketch
A	Chair back	1		B	Front frame	1	
C	Side Apron (L-R)	2		D	Seat	1	

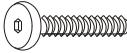
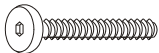
Printed in Vietnam

# HARDWARE LIST

When unpacking, please be careful not to discard any parts with the packaging. Before continuing, please make sure you have all of the following hardware:

NO	Description	Qty	Sketch	NO	Description	Qty	Sketch
1	Short bolt (M6x40mm)	4		2	Long bolt (M6x50mm)	2	
3	Screw (M4x30mm)	3		4	Flat Washer (φ6.5x14mm)	4	
5	Lock Washer (φ6.5x11mm)	4		6	Curve Washer (12x16mm)	2	
7	Allen Key (4mm)	1					

## STEP 1

Attach Side Aprons (C) to the Back (A) with Short bolts (1), and Washers (4) and (5). Tighten with the Allen Key (7)

Note: DO NOT fully tighten any of the bolts, until the chair is assembled, then put on a flat level surface to make sure the chair is level and then tighten the bolts.

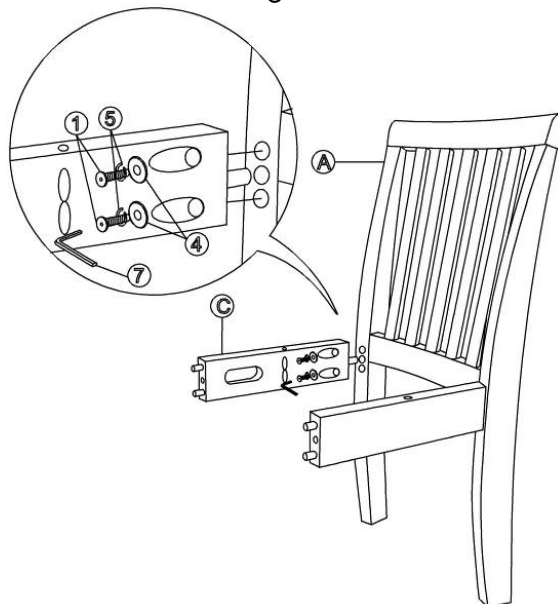

## STEP 2

Attach Front frame (B) to Side Aprons (from Step 1) with bolts (2) and Curve Washers (6). Tighten with the Allen Key (7)

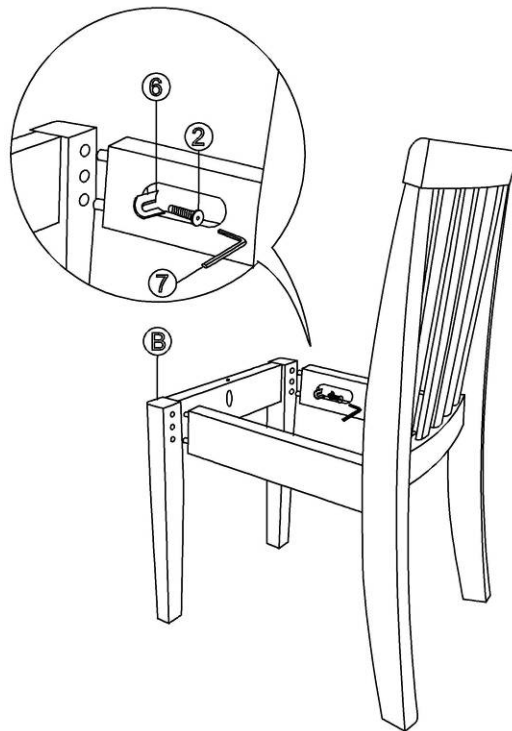

## STEP 3

Attach the Seat (D) to top of the seat frame (from Step 2) by using Screws (3). Tighten with a screw driver.

