

INSTALLATION GUIDE

4" DOWNLIGHT RETROFIT ROUND

LR24870, LR24871, LR24872, LR24873, LR24874, LR24875, LR24876, LR24877, LR24878, LR24879

PLEASE READ CAREFULLY AND SAVE THESE INSTRUCTIONS, AS YOU MAY NEED THEM AT A LATER DATE.**WARNING - RISK OF FIRE OR ELECTRIC SHOCK****DISCONNECT MAIN POWER AT FUSE OR CIRCUIT BREAKER BEFORE INSTALLING OR SERVICING THE FIXTURE.**

- DO NOT MAKE OR ALTER ANY OPEN HOLES IN THE ENCLOSURE TO THE WIRING OR ELECTRICAL COMPONENTS DURING KIT INSTALLATION.
- TO PREVENT WIRING DAMAGE OR ABRASION, DO NOT EXPOSE WIRING TO EDGES OF SHEET METAL OR OTHER SHARP OBJECTS.
- SUITABLE FOR WET LOCATIONS
- SUITABLE FOR TYPE IC OR SUITABLE FOR TYPE NON-IC
- USE ONLY IN OPEN LUMINAIRES
- THIS DEVICE IS NOT INTENDED FOR USE WITH EMERGENCY EXITS

GENERAL: ALL ELECTRICAL CONNECTIONS MUST BE IN ACCORDANCE WITH LOCAL AND NATIONAL ELECTRICAL CODE (N.E.C.) STANDARDS. IF YOU ARE UNFAMILIAR WITH PROPER ELECTRICAL WIRING CONNECTIONS OBTAIN THE SERVICES OF A QUALIFIED ELECTRICIAN,

ASSEMBLY AND INSTALLATION

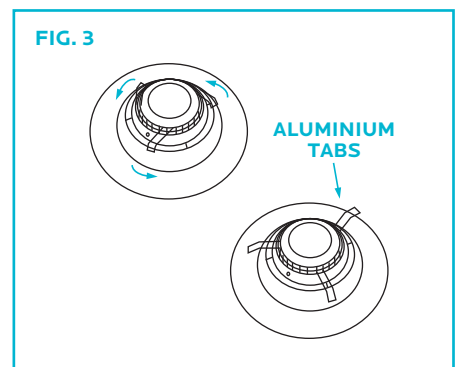
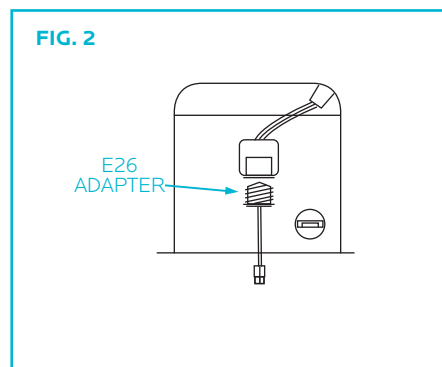
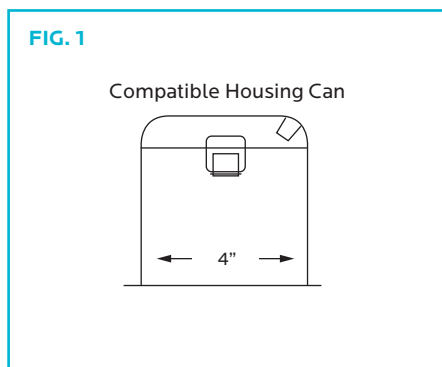

• Thread the SOCKET ADAPTER into the SOCKET.

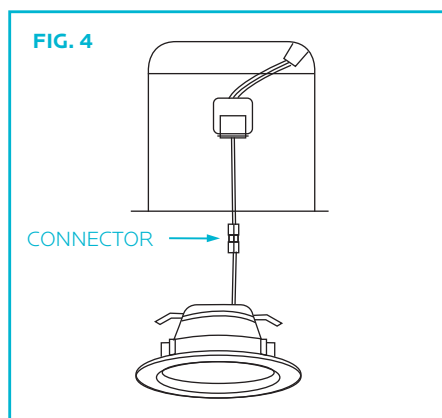

• Plug the FEMALE CONNECTOR of the RETROFIT TRIM onto the MALE CONNECTOR of the HALO HOUSING.

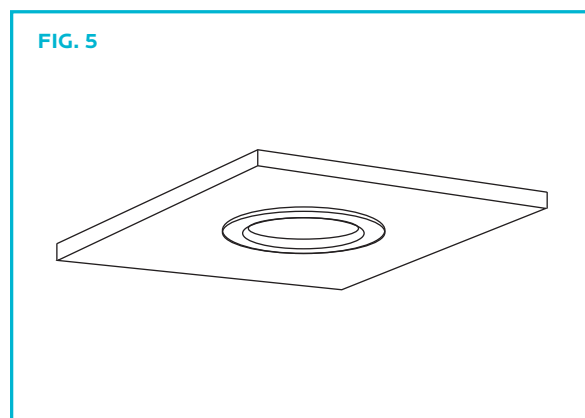

• Tuck all wires into the CAN and carefully push the RETROFIT TRIM into CAN. (NOTE: To provide enough room in shallow cans, carefully position SOCKET ADAPTER and SOCKET adjacent to the long side of the LED DRIVER prior to inserting the RETROFIT TRIM into the CAN.)

DIMMING: Dimming performance may depend on the dimmer, the dimmer range adjustment setting (for dimmers with brightness range adjustments), the wiring method, and/or the number of LED modules installed onto the dimmer circuit. For dimmer selection, Dimming control manufacturers revise their product often; for the latest list of compatible dimmers please visit: www.allstarlighting.com

For best results, it is recommended to install a minimum of four LED modules onto one dimmer. Before turning on the LED lights, set dimmer position at maximum before adjusting to a lower light level. Please follow the dimming control manufacturer's instructions for the installation of all dimming controls.