

Attention: Do not tighten the bolts and screws before all the allen bolts are in place

USER'S MANUAL

Round Table

DETAIL:

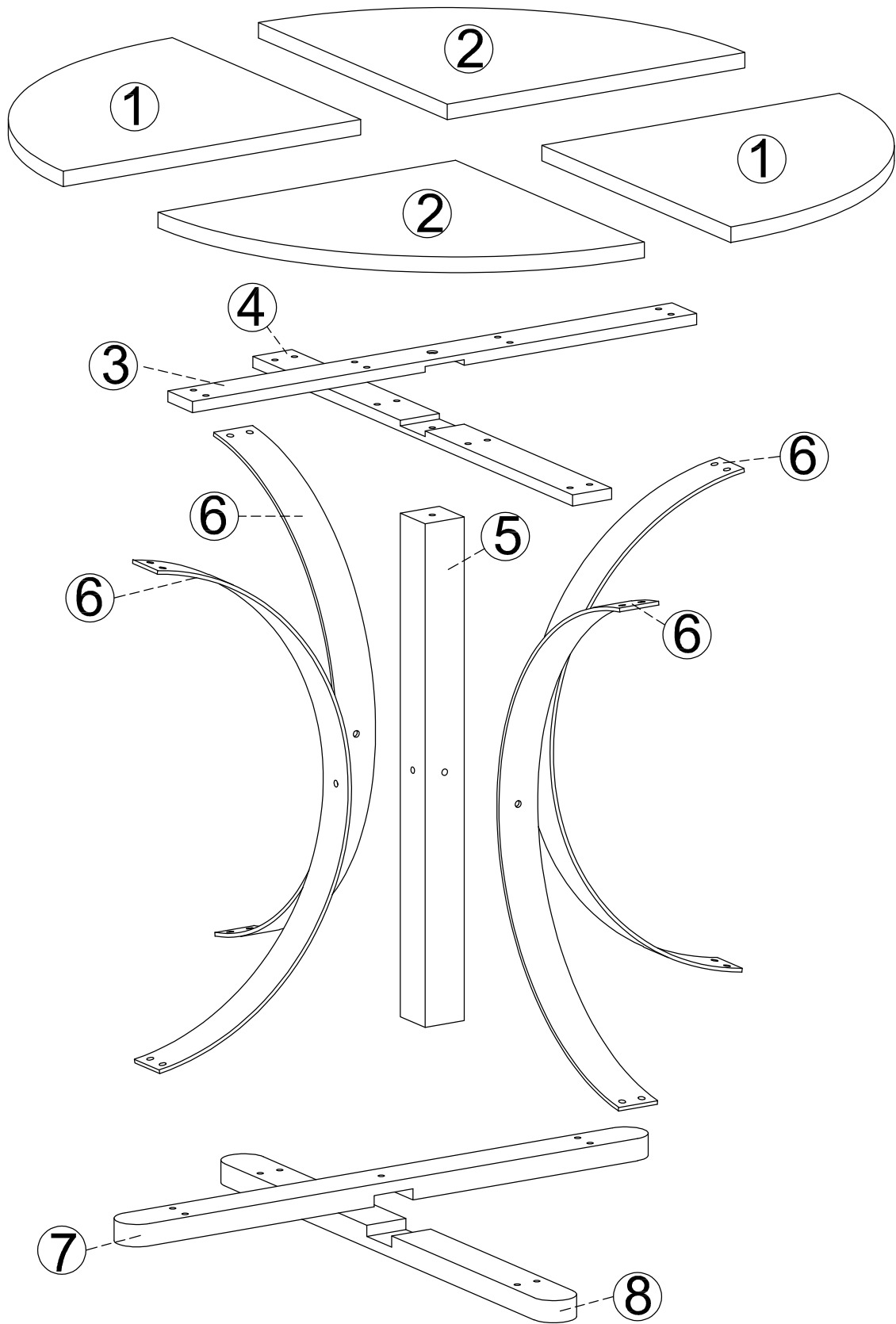

BEFORE YOU GET STARTED, A FEW POINTS



Mind the important
safety information

PLEASE MAKE SURE ALL THE PARTS ARE INCLUDED

Part List :



1 Top panel
(2pcs)

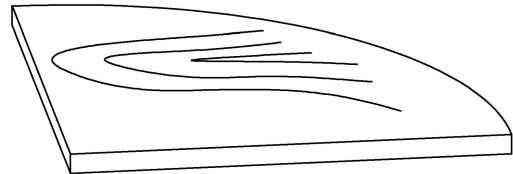

2 Top panel
(2pcs)



3 Top support rail
(1pc)

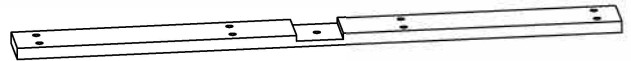

4 Top support rail
(1pc)

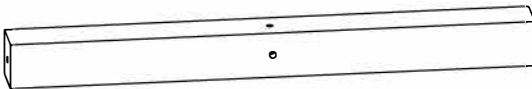

5 Wood port
(1pc)

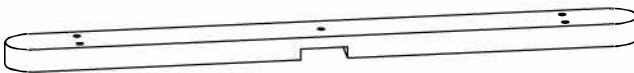

7 Wood bottom support
(1pc)

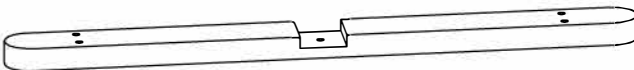

8 Wood bottom support
(1pc)

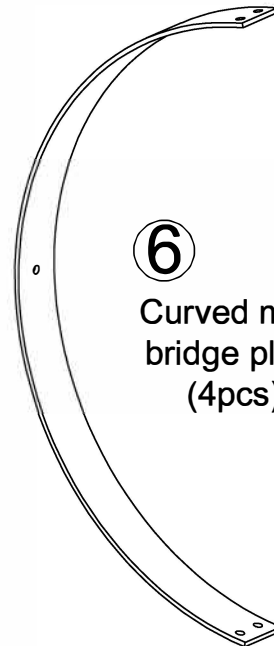

6 Curved metal
bridge plate
(4pcs)

BEFORE YOU GET STARTED, A FEW POINTS



Mind the important
safety information

PLEASE MAKE SURE ALL THE PARTS ARE INCLUDED

Hardware List :

A

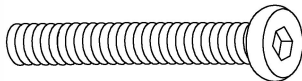

Bolts
1/4"x38mm
(2pcs)

B

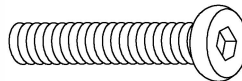

Bolts
1/4"x30mm
(16pcs)

C

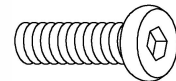

Bolts
1/4"x15mm
(20pcs)

D

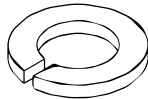

Spring Washer
Ø1/4"
(16pcs)

E

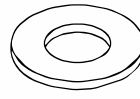

Flat Washer
Ø1/4"x19x1.5mm
(16pcs)

F



Allen Key
M4x60mm
(1pc)

G

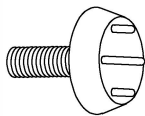

Adjustable screw
Ø1/4"x19x15mm
(4pcs)

H

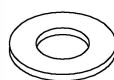

Flat Washer
Ø1/4"x13x1.5mm
(20pcs)

ASSEMBLY INSTRUCTIONS - ATTENTION

Step 1: Place all parts on a clean, scratch-free surface.

Assemble parts 5 - 7 - 8

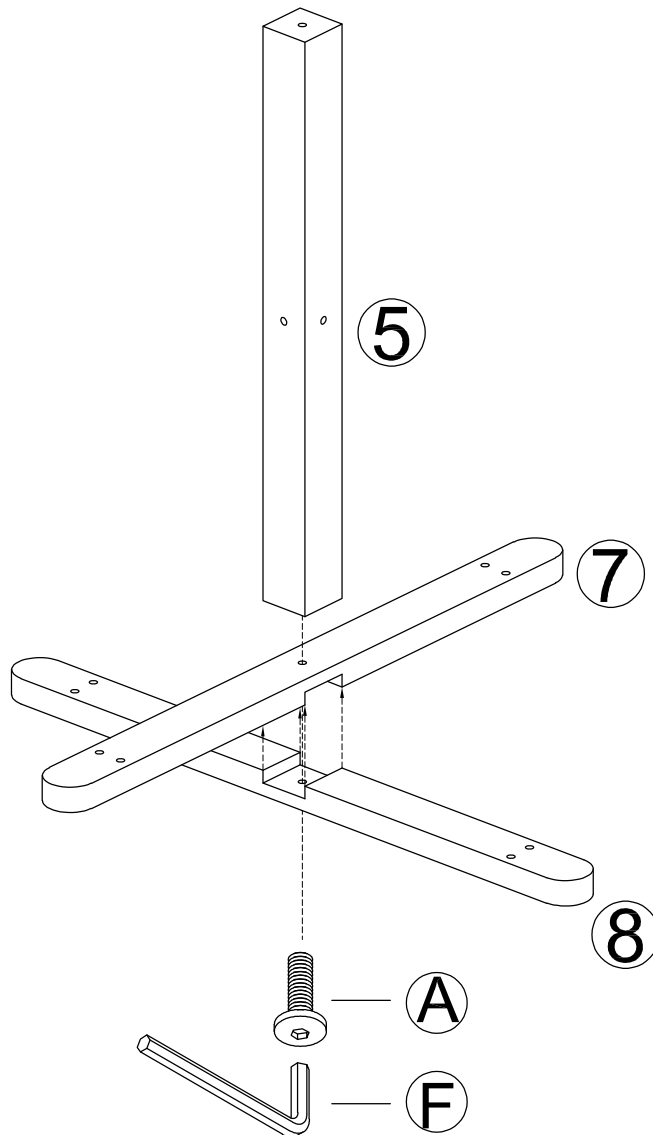

ASSEMBLY INSTRUCTIONS - ATTENTION

Step 2: Place all parts on a clean, scratch-free surface.

Assemble parts 3 - 4 - 5

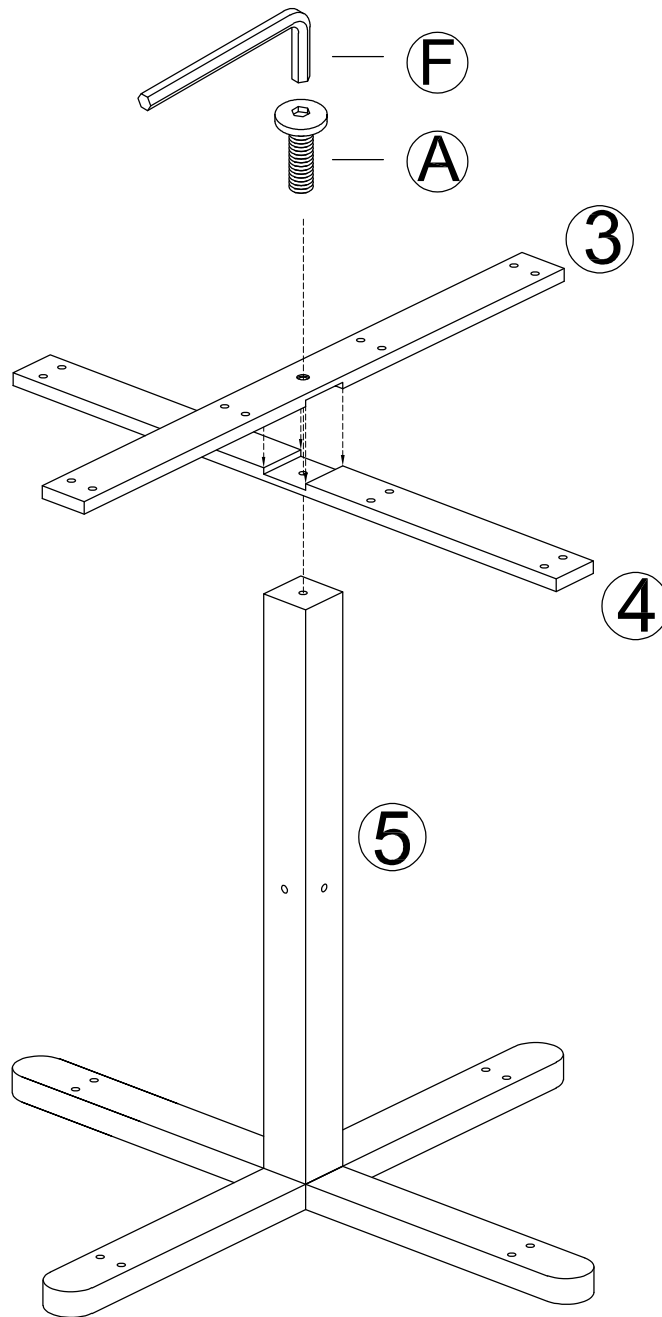

ASSEMBLY INSTRUCTIONS - ATTENTION

Step 3: Assemble parts 6

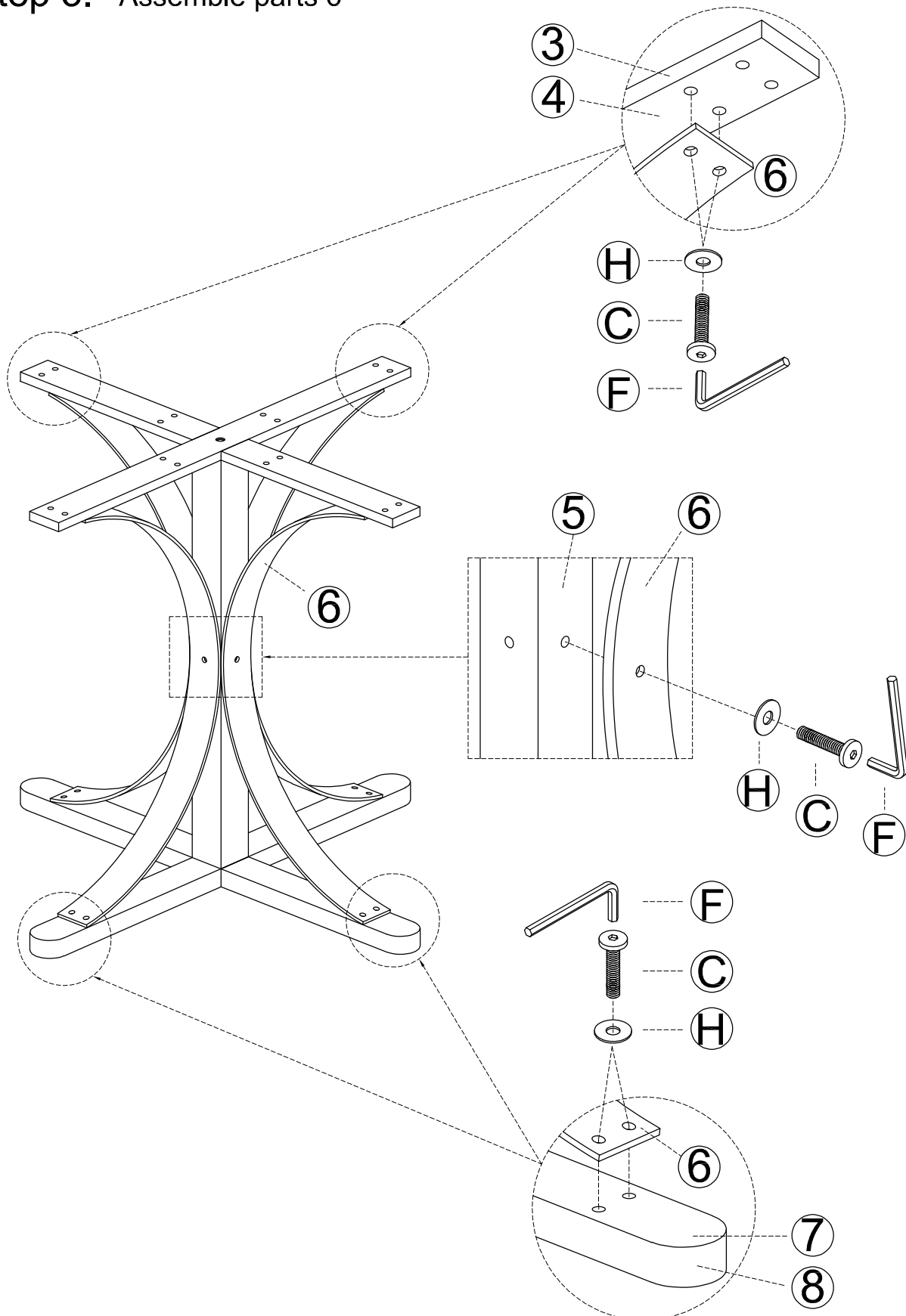

ASSEMBLY INSTRUCTIONS - ATTENTION

Step 4:

Make sure the tabletops are facing the same direction, then push them tightly together and securely tighten the bolts.

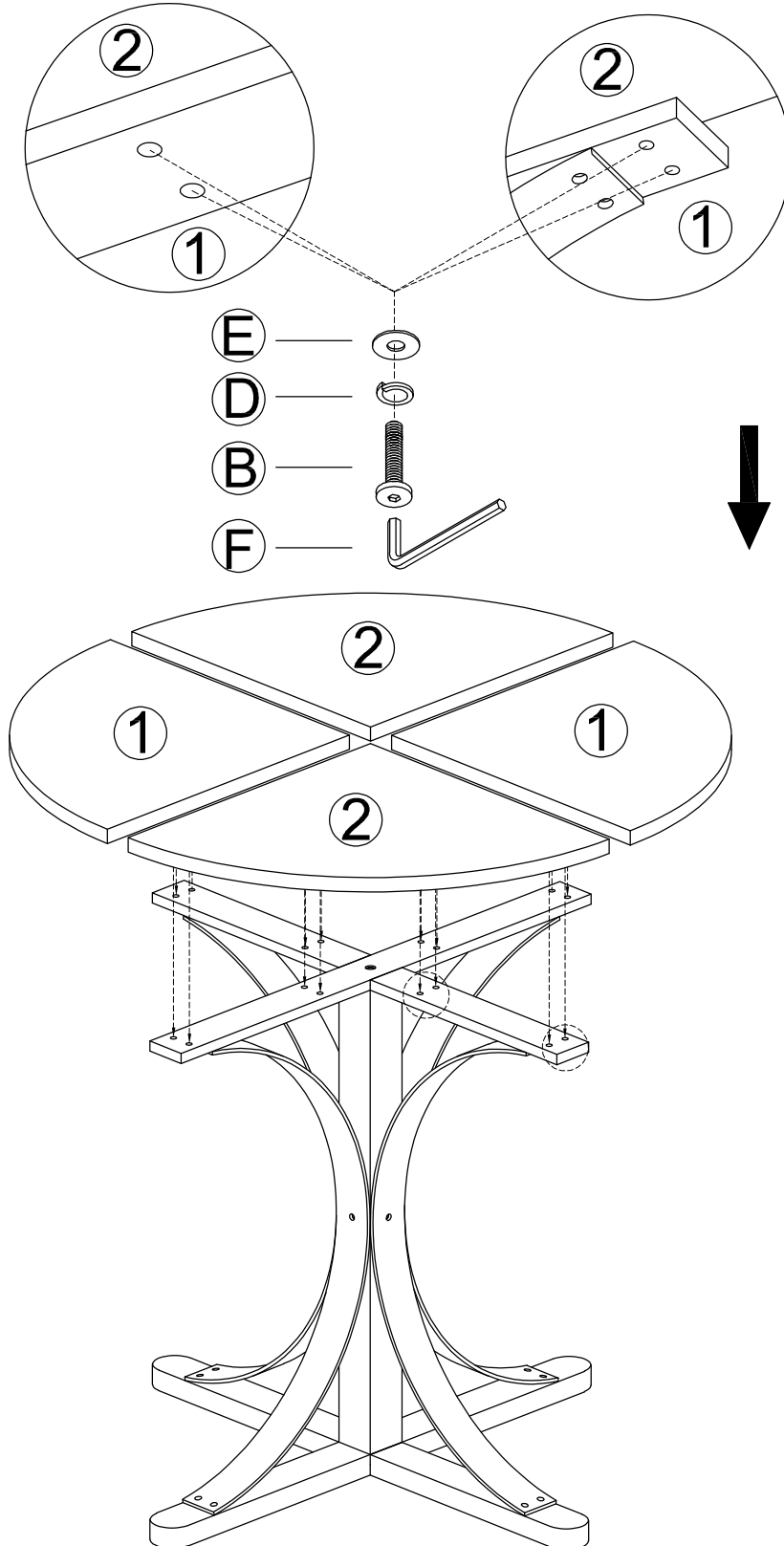

ASSEMBLY INSTRUCTIONS - ATTENTION

Step 5: Screw in the adjustable levelers to make sure the table top level.

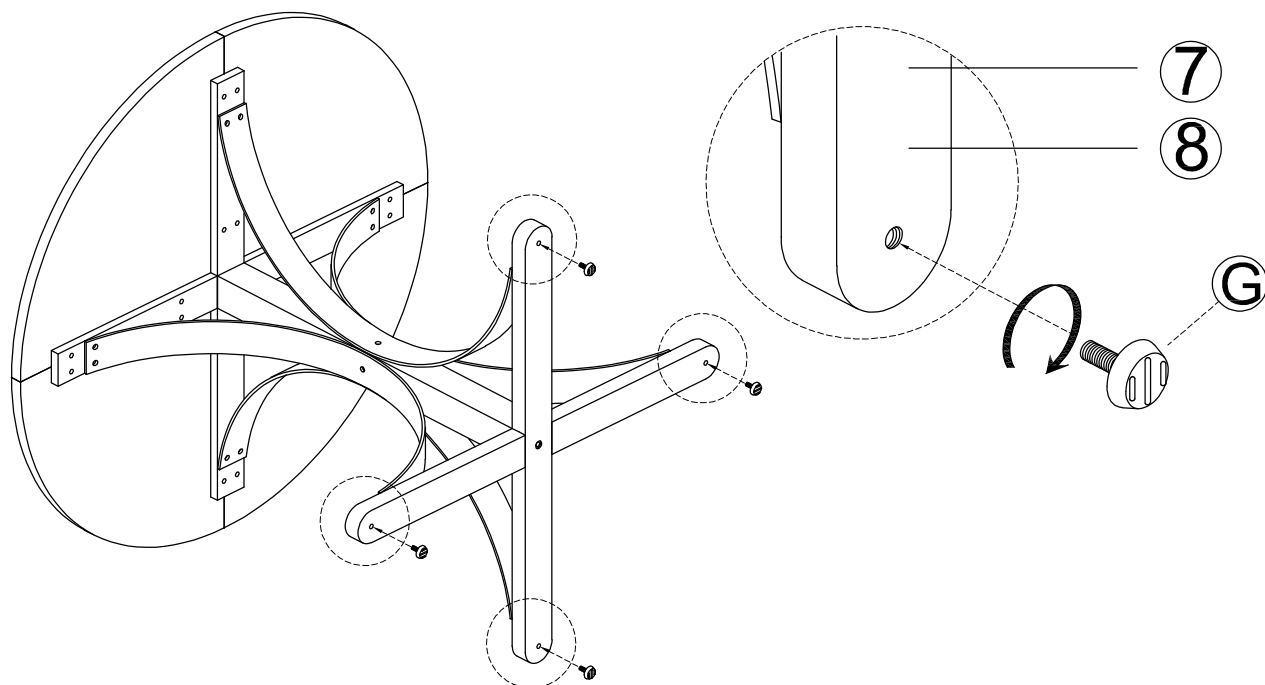

Completed:

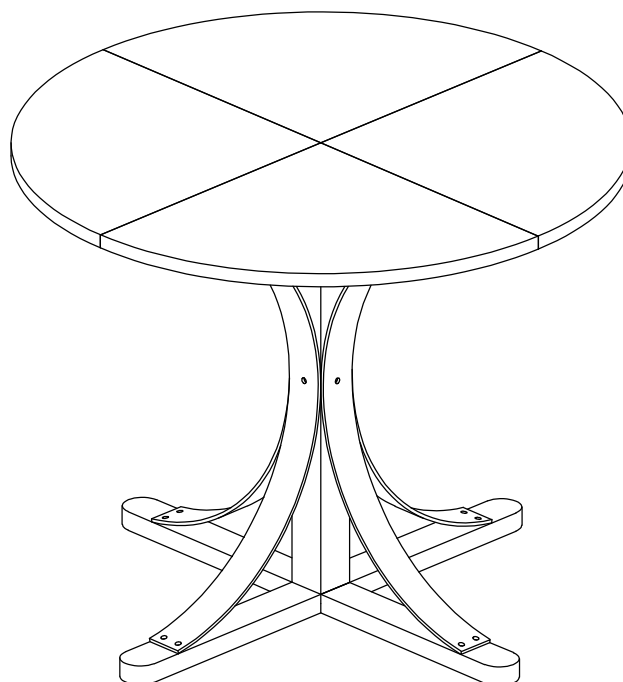



WARNING



Read the instructions carefully.



Please follow the assembly steps

Safety maximum Weight: 150 LBS

To ensure proper assembly, follow all steps and use all parts, do not use power tools. Failure to follow this warning can result in serious injury to yourself or others.

Please inspect all items before assembly, if for any reason you need to return this item, please kindly return in its original packaging.

To avoid misalignments, leave the screws loose and do not tighten them until all are in their respective places.

Do not tighten all bolts and screws completely until the entire unit has been assembled and set up.

Do not over tighten or force the screws as they could break, strip, or damage the threads of the holes.

Using the wrong size of screws on a part could result in damage to the screw or the part.

Lubricate all moving parts and tighten all bolts/screws every 6 month or whenever needed.

Do not use if this product become damaged, and/or components are broken or missing.