

Recommended Maximum Weight

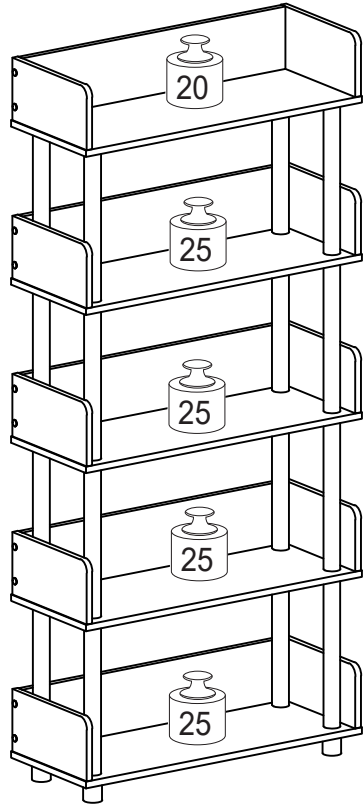

*Unit in Pound(lbs.)

WARNING:

>This unit has been designed to support the maximum loads shown. Exceeding these load limits could cause sagging, instability, product collapse, and/or serious injury.

>DO NOT allow children to climb on unit.

> Put heavier items on lower shelves.

00:30

Approx. 30 minutes



Recomm. 1 Person

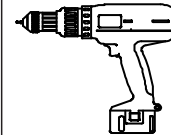



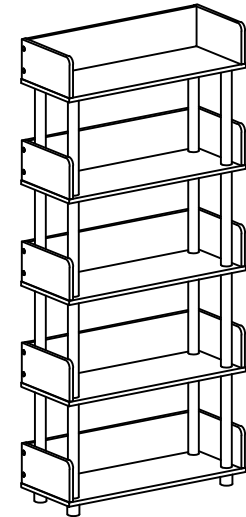

Tools Required

Assembly Instruction

5-TIER DISPLAY RACK

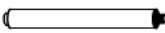

HARDWARE & PARTS LIST

NO	HARDWARE LIST	QTY
1	POLE 	16pcs
2	FASTENER 	45pcs
3	LEG 	4pcs
4	WALL MOUNT SET 	2sets

NO	PARTS LIST	QTY
A	TOP PANEL	1pc
B	SHELF PANEL	4pcs
C	SIDE PANEL	10pcs
D	BACK PANEL	5pcs

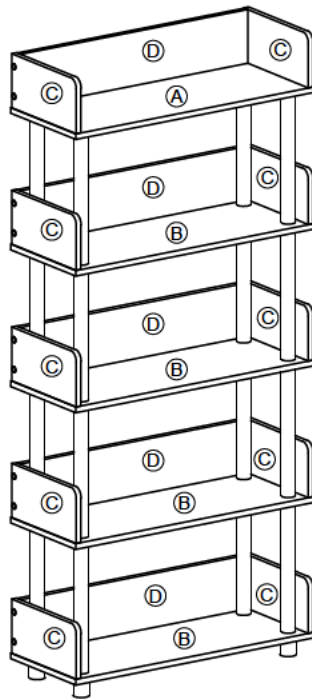







USEFUL HINTS BEFORE YOU START:

1. Read each step carefully before starting.
2. It is important that each step is performed in correct order to avoid difficulties.
3. Identify, sort and count the parts before assembly.
4. Assemble your furniture on packaging cardboard to prevent scratch or damage.
5. Clean the product with mild cleanser using soft dampened cloth. Do not use harsh or abrasive cleanser.
6. Using incompatible hardware might cause damage to product.

STEP 7

PLEASE FOLLOW BELOW INSTRUCTION TO PREVENT PRODUCT TIP OVER.

HARDWARE LIST			QTY
			2 Sets
			

WALL

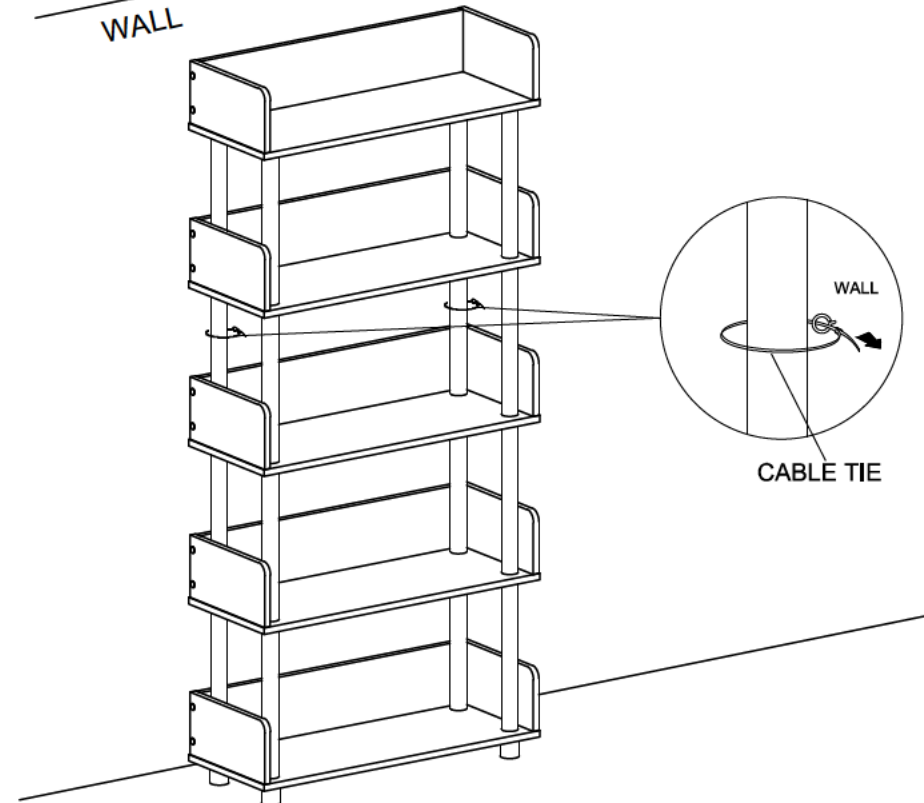

STEP 6

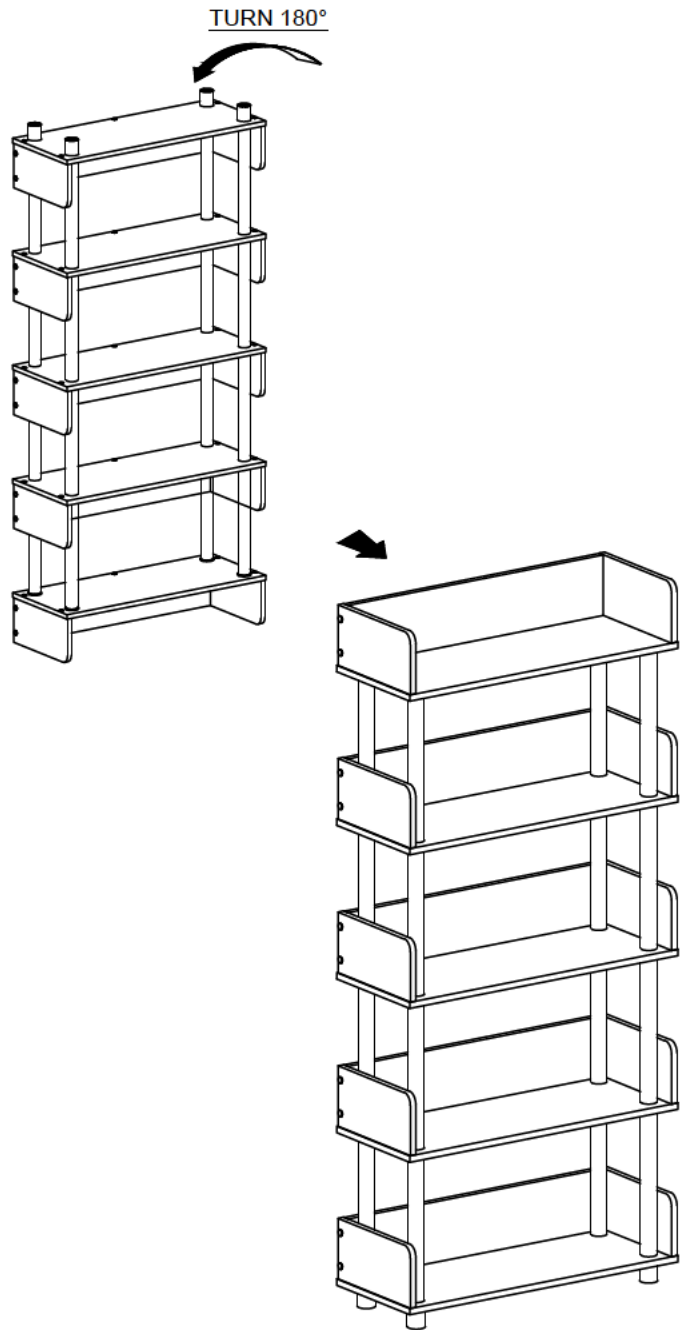

ASSEMBLY INSTRUCTIONS

BEFORE YOU BEGIN, PLEASE READ ASSEMBLY INSTRUCTIONS CAREFULLY,
FOLLOW THEM STEP BY STEP.

STEP 1

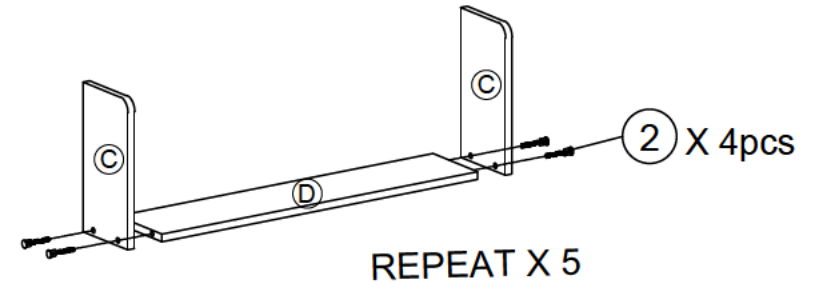

STEP 2

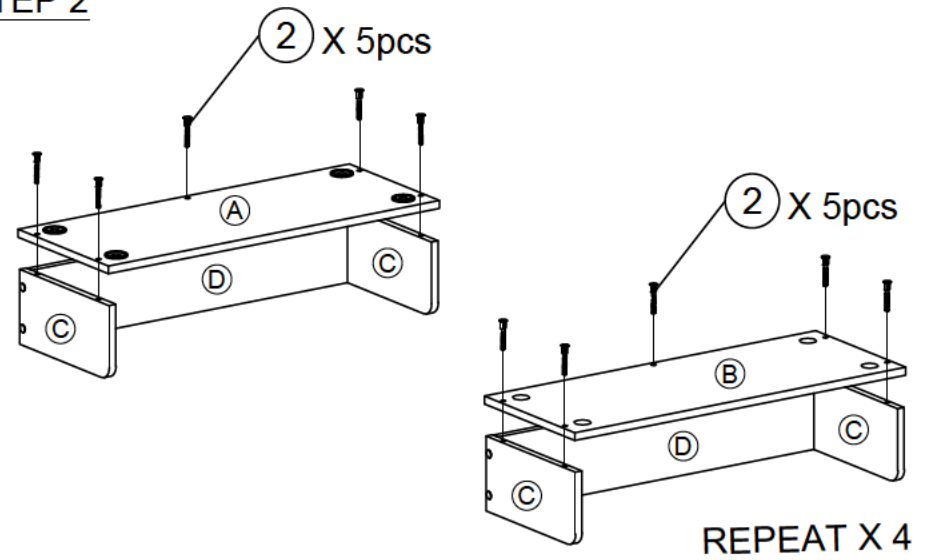

STEP 3

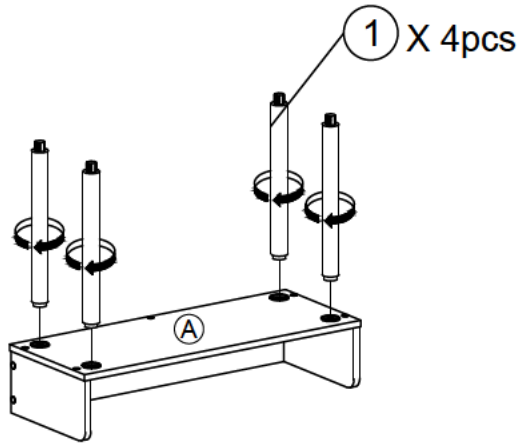

STEP 4

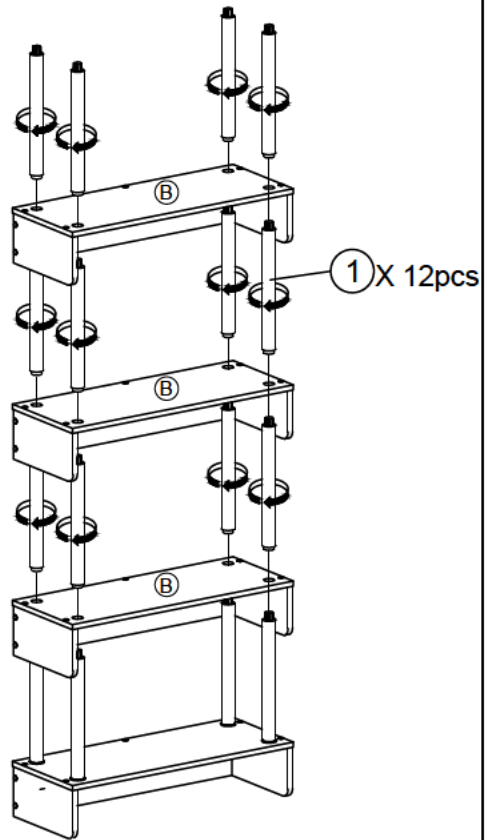

STEP 5

