

*Cantilever*

8.6' Square

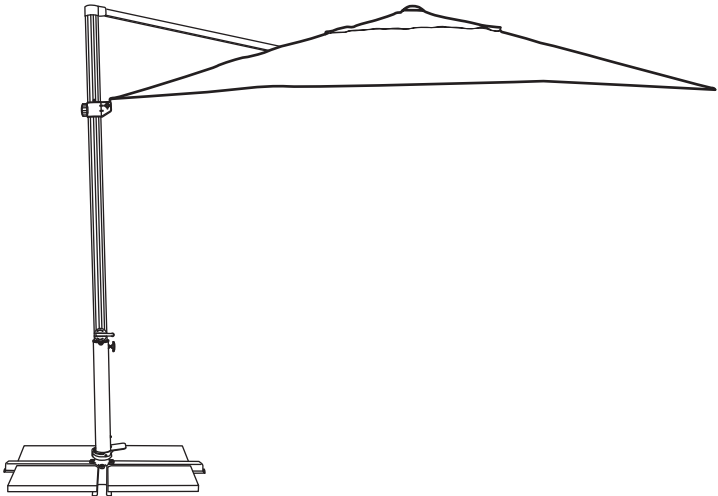

Instruction Manual

Thank you for your purchase of Cantilever Umbrella.

Please remove all contents from the package, inspect and review checklist.

**CAUTION:** To reduce personal injury and damage to your umbrella, read and follow this assembly and operation guide. We recommend a two-person team for assembly and disassembly. *Save information for future reference.*

## CHECKLIST

- |                    |                       |            |
|--------------------|-----------------------|------------|
| A - Cross Bars (2) | E - Crank Lift Handle | I - Canopy |
| B - Rotation Hub   | F - Main Frame        |            |
| C - Column         | G - Adjustment Knob   |            |
| D - Knob           | H - Light Adapter     |            |

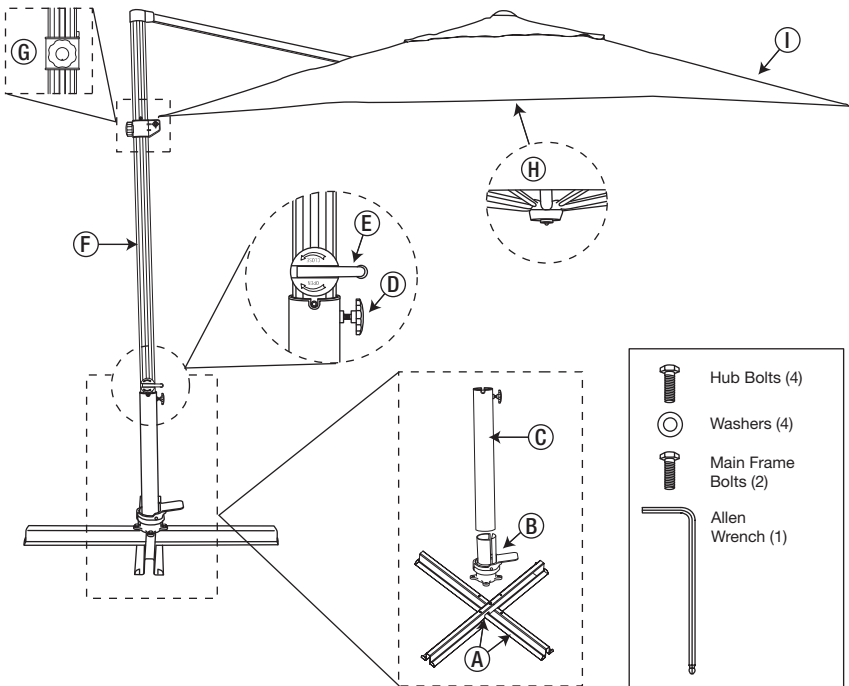

## REQUIRED FOR ASSEMBLY:

- Four (4) 50 lb. weights - square stones or concrete weights. (200 lb. total weight needed for support - **weights not included**) Stones & weights, standard sizes can be used up to 18" L x 18" W x 1.5" H.

**NOTE:** Using the cross bar stand without weights will damage your umbrella and may cause injury.

## STEP 1 Assemble Cross Bar Stand

Assemble the umbrella base by connecting both sections in a cross (Fig. 1). Place the rotation hub on the connected crossed base and fasten (4) four hub bolts and washers with allen wrench (both supplied) (Fig. 2). Insert the column into the rotation hub and then fasten the (2) two supplied main frame bolts with allen wrench (Fig. 3). Attach knob loosely onto column. Do not tighten or main frame will not insert into column in Step 2. Secure umbrella base with (4) four square stones or concrete weights (weights not included).

**IMPORTANT: Cross bar stand will not support umbrella without proper weights. Using the stand without weights will damage your umbrella.**

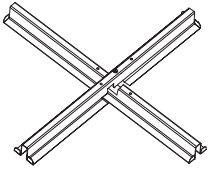

(Fig. 1)

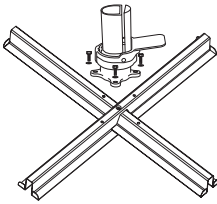

(Fig. 2)

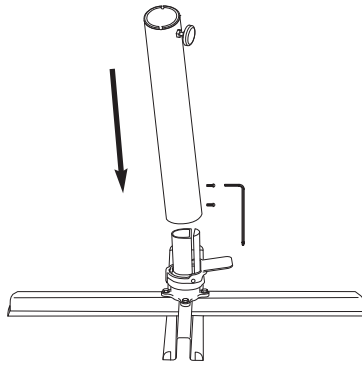

(Fig. 3)

## STEP 2 Assemble Frame

**NOTE: Two persons may be needed for the following action.**

Lift umbrella up and insert the main frame into the column (Fig. 4). Lock into place by tightening knob on column. Secure the canopy at the same direction with the foot pedal on the rotation hub, and then loosen the umbrella tie.

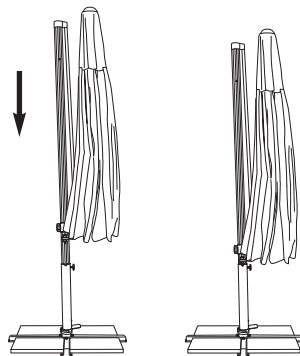

(Fig. 4)

### STEP 3 Opening Canopy

In the closed position (see below), turn the crank lift handle clockwise  and slide the adjustment knob upward until the canopy is fully opened and the slider is at the top most position (Fig. 5). Now the umbrella is ready to use.

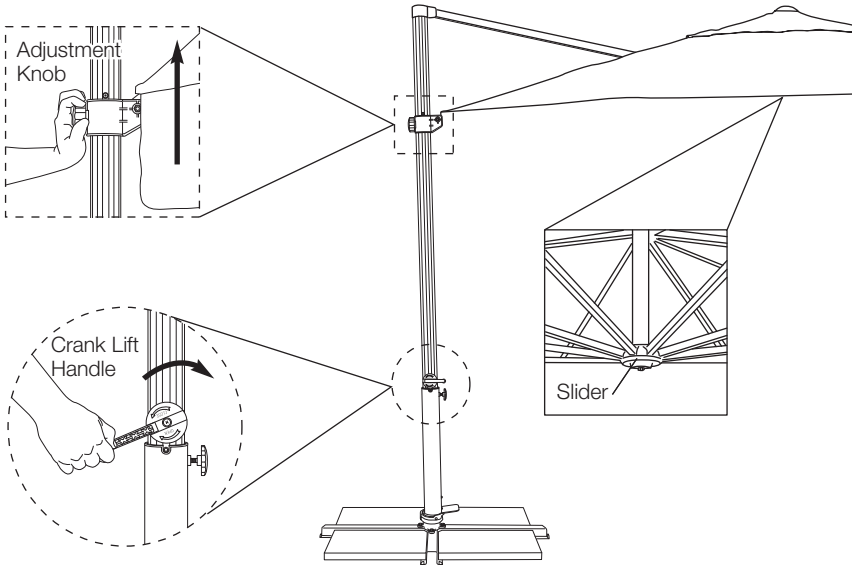

(Fig. 5)

### STEP 4 Closing Canopy

Slide the adjustment knob downward and turn the crank handle  counter-clockwise until the canopy is fully closed.



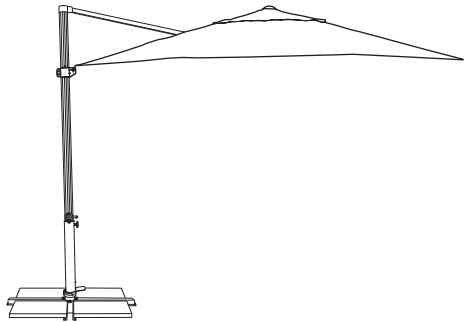

CLOSED



OPENED

### STEP 5 Adjusting Height and Tilt

Loosen the adjustment knob counter-clockwise  (Fig. 6) to adjust height and tilt. Slide the adjustment knob up or down to adjust the umbrella to your desired height and angle. Tighten the adjustment knob clockwise  to lock its position.

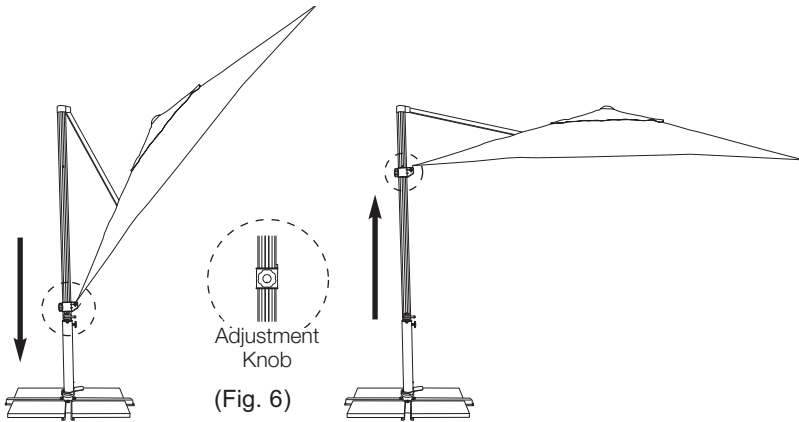

### STEP 7 360° Rotating Hub Swivel

Place your foot on the foot pedal of the rotating hub and *step-on* the pedal to release rotating lock (Fig. 7). Place hands on the main frame (Fig. 8) and rotate the umbrella frame in either direction, in 90° increments (Fig. 9). To lock position, step off the foot pedal to engage rotating lock.

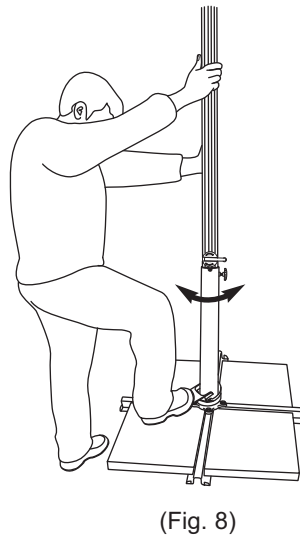
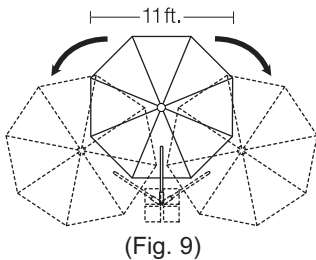
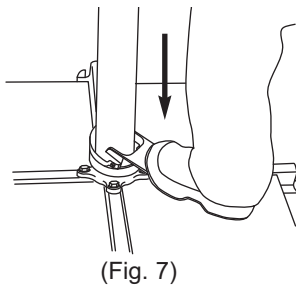

## Features

### To ATTACH Umbrella Light:

Loosen the light adapter built into the umbrella runner by turning counter-clockwise  (Fig. 10). After loosening, pull down light adapter post (Fig. 11) to attach umbrella light (sold separately).

### To REMOVE LIGHT and CLOSE adapter:

Remove umbrella light, and gently push up the light adapter post back into umbrella runner and tighten turning clockwise (Fig. 10). 

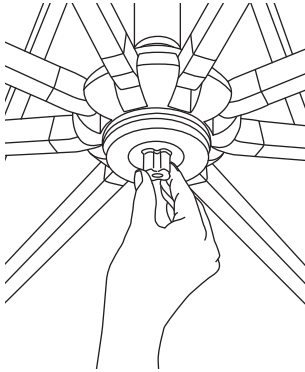

(Fig. 10)

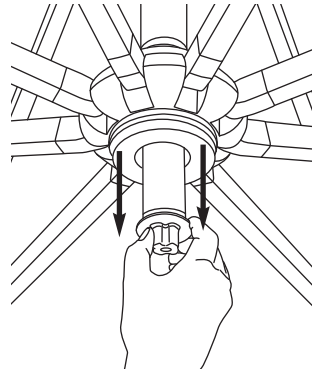

(Fig. 11)

## WARRANTY:

We warrant that this umbrella, when subject to normal and proper use, will be free from manufacturing defects for a period of one year from the original date of purchase. Should any defect occur during the specified time period, the manufacturer will repair, replace, or provide replacement parts, at its own option. Limited warranty against fabric fading, based on fabric grade. Warranty is not transferable.

We will not warrant any claim coverage unless both the original sales receipt and request form are sent to us. Any items that are returned for warranty or non warranty purposes must be issued a Return Authorization Number. Only

upon issuance of an RA # and inspection by our QC department will credit or replacement of umbrella be issued. It is the customer's responsibility to pay the freight on return products or replacement parts. ALL RETURNED ITEMS MUST INCLUDE THE RA# CLEARLY WRITTEN ON THE RETURN PACKAGE or package will be refused by our warehouse personnel.

NOTE: Damages and failure caused by improper use due to neglect of reasonable and necessary care are not covered by this warranty.

Additionally, acts of nature (including but not limited to wind, hurricanes, tornadoes, and storms) are not covered by this warranty.

## S A F E T Y P R E C A U T I O N S :

- Close the umbrella in windy conditions or when a storm approaches. Never allow the umbrella to flap in the wind; this could damage the canopy.
- Do not leave open umbrella unattended. If damage occurs, this is not covered by the warranty.
- When adjusting the umbrella, make sure that no person(s) or item(s) are close to the umbrella. This is important to prevent injury or material damage.

## C A R E A N D M A I N T E N A N C E :

- When not in use, close and cover umbrella with a protective cover (sold separately).
- Allow a wet canopy to dry opened up.
- If necessary, clean the fabric with lukewarm water, mild detergent, and a sponge.
- Wipe sliding marks on the aluminum poles with a damp cloth.

### Winter Storage:

- Store in a dry, protective place.
- Any visible defects must be repaired by a professional.

### After the Winter:

- Areas subject to turning and sliding can be treated with a non-staining lubricant spray (silicone-based).
- Check the condition and function of the umbrella. Any defects must be repaired by a professional.