

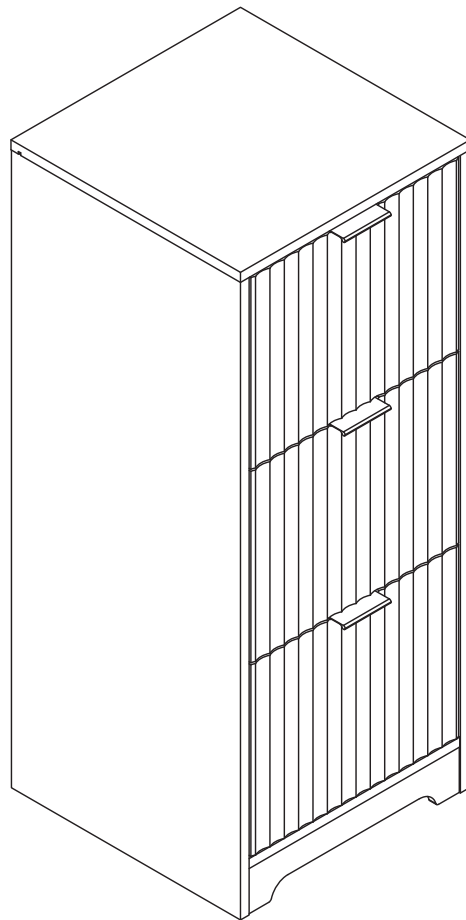

VINGLI FILE CABINET

ASSEMBLY INSTRUCTION



Thank you for purchasing from VINGLI!
Please contact us via email if parts are missing or damaged, we will gladly ship your replacement parts free of charge

⚠ IMPORTANT

THIS INSTRUCTION BOOKLET CONTAINS IMPORTANT SAFETY INFORMATION.
PLEASE READ AND KEEP FOR FUTURE REFERENCE.

RETURN & WARRANTY

Thank you for choosing our product!

We would like to take this opportunity to thank you for choosing VINGLI.

We hope that you are completely satisfied with your purchase, and enjoy it for years to come.

Your satisfaction is our highest pursuit.

Return policy

VINGLI believes you will absolutely love your furniture, but if for some reason you want to return the product, please contact us directly before you decide to return your product to the retailer. Our Customer Service organization can answer most concerns and can assist you with any questions you may have about your new product.

The item must be returned in good condition, in original box, with all original proof of purchase, parts and accessories, within the time frame specified by the retailer it was purchased from.

Warranty

VINGLI warrants this product to be free from defects in material and workmanship agrees to remedy any such defect. This warranty covers one year from the date of original purchase. This is solely limited to be repair or replacement of defective parts and no assembly labor is included.

This warranty does not apply to any product which has been improperly assembled, subjected to misuse or abuse or which has been altered or repaired in any way.

Components repaired or replaced warranted through the remainder of the original warranty period only. The defective components will be repaired or replaced without charge, subject to the terms and conditions described above.

For help with assembly, identifying parts, product information or to order parts, please contact us freely.

BEFORE STARTING

Before Using Product



- Read each step carefully before starting. It is very important that each step is performed in the correct order. If these steps are not followed in sequence, assembly difficulties will occur.



- Make sure all parts are included. Most board parts are labeled or stamped on the raw edge.

- Prepare a flat and Philips screwdriver (not included)
A Power Screwdriver is recommended.



- Work in a spacious area and near where the unit will be used, preferably on a carpet, or use a piece of the cardboard packaging to protect your floor and product.



- For a smooth assembly process, we suggest you keep a lite tightness for all the screws during assembly. After the whole product is assembled, firmly tighten all the screws.

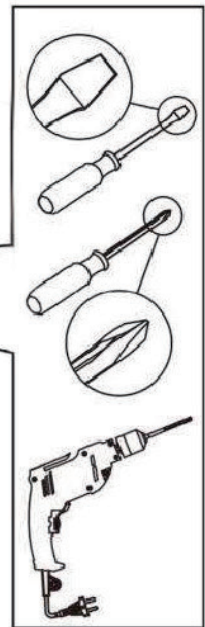

Estimated People for Assembly

2

WARNING:

- Do not allow children to climb on unit
- Serious or fatal crushing injuries can occur from furniture tip-over. To prevent this furniture from tipping over, it must be permanently fixed to the wall. Fixing devices for the wall are not included since different wall materials require different types of fixing devices. Use fixing devices suitable for the walls in your home. For advice on suitable fixing systems, contact your local specialized dealer
- Avoid sharp objects or corrosive chemicals to prevent damage to the product
- During assembly, keep parts and packaging materials away from children and pets as there could be potential injury and choking hazards

IDENTIFY PARTS

One unit

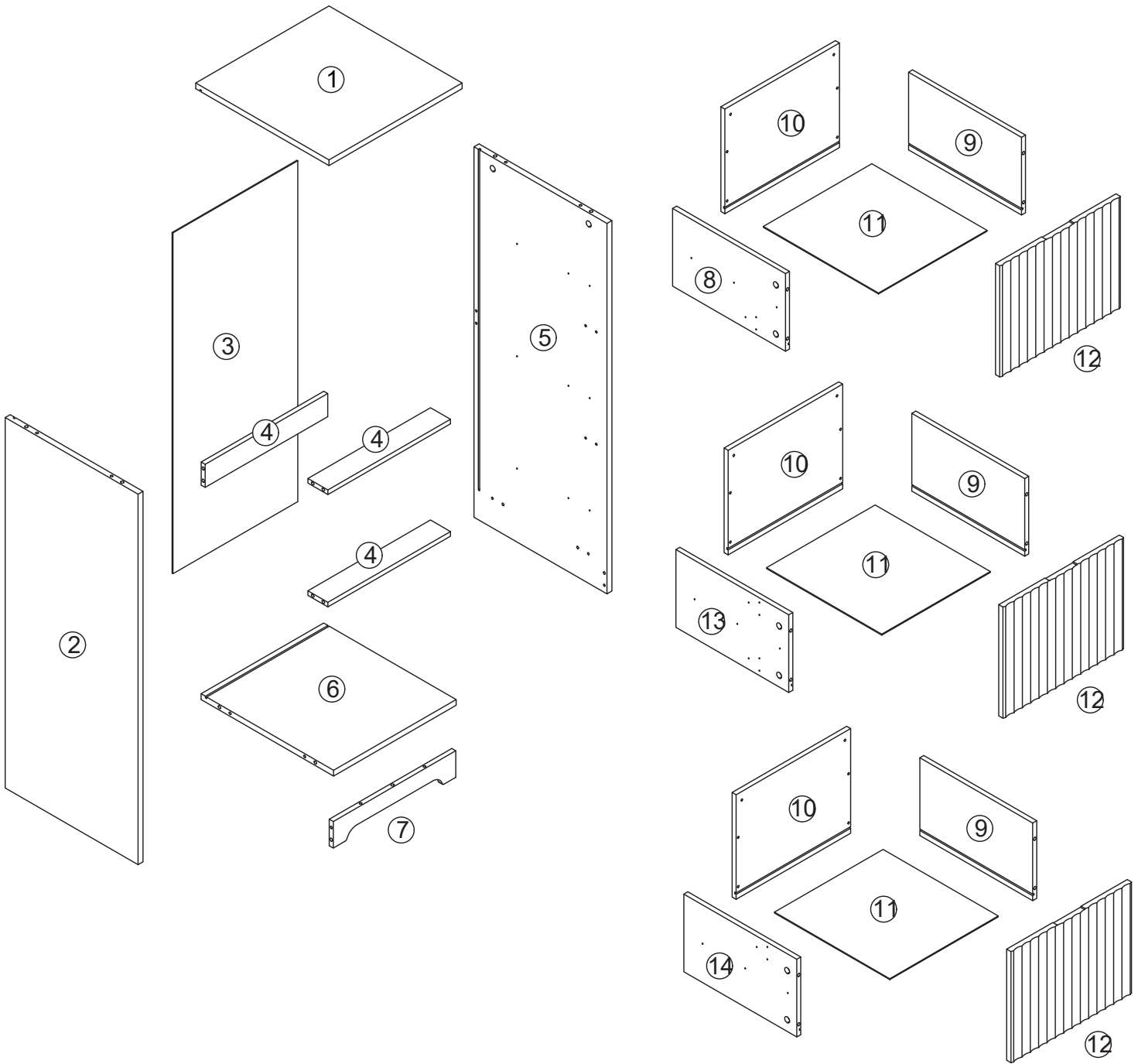

COMPONENTS

1

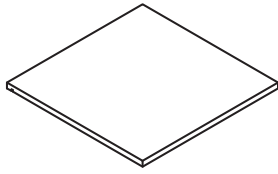

399x399x15mm

Top Panel x1

2

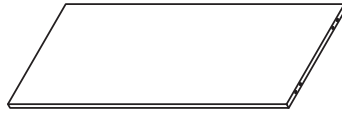

963x398x15mm

Left Side Panel x1

3



886x375mm

Back Panel x1

4

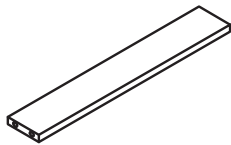

368x59x12mm

Wood Strip x3

5

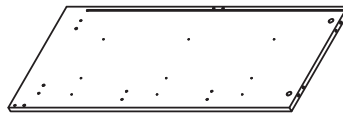

963x398x15mm

Right Side Panel x1

6

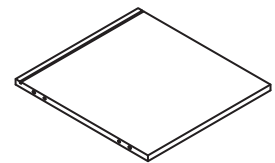

368x397x15mm

Bottom Panel x1

7

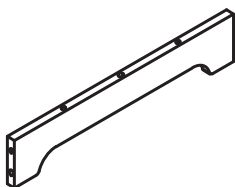

368x69x12mm

Bottom Brace Panel x1

8

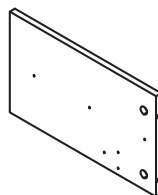

339x201x12mm

Upper Drawer Left Panel x1

9

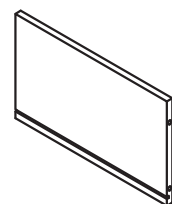

339x201x12mm

Drawer Right Panel x3

COMPONENTS

10

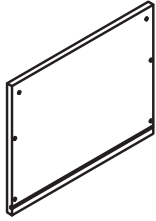

343x271x12mm

Drawer Back Panel x3

11

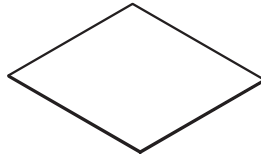

346x326mm

Drawer Bottom Panel x3

12

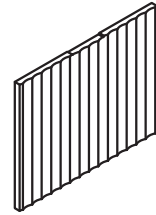

362x289x15mm

Drawer Front Panel x3

13

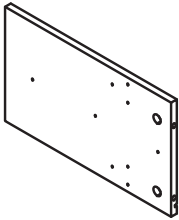

339x201x12mm

Middle Drawer Left Panel x1

14

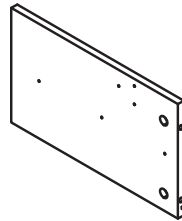

339x201x12mm

Lower Drawer Left Panel x1

COMPONENTS

A

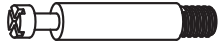

+3(spare)

Φ6X35mm

Cam Bolt x35

B



+3(spare)

Φ15X10mm

Cam Lock x35

C

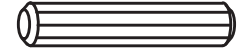

+1(spare)

Φ6X30mm

Wood Dowel x12

D



+1(spare)

Φ4X35mm

Screw x12

E



+6(spare)

Φ3X12mm

Screw x54

F

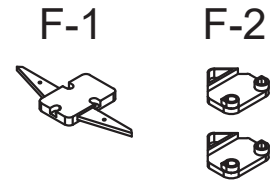

Anti-tip Component x2

G

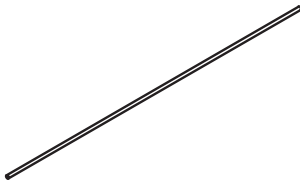

353mm

Hanging Rod x6

H

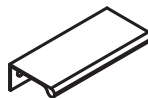

L100

Handle x3

I

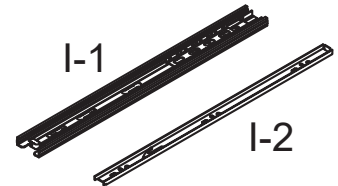

L330

Three-section Drawer Slide x6

J



Φ4X45mm

Plastic Anchor & Washer & Screw x2

K

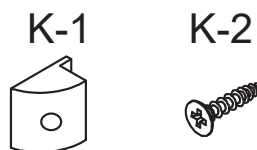

Φ3X16mm

Back Panel Wedge & Screw x8

L

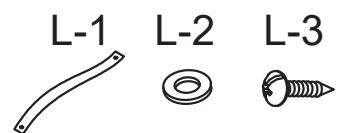

Φ4X12mm

Anti-tipping Strap & Washer & Screw x2

COMPONENTS

M

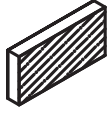

Foot Pad x4

N



Φ3X16mm

Screw x6

ASSEMBLY STEPS

* Before assembling the drawer slide, it needs to be disassembled first. As shown in the figure, press the detaching button on the side of the drawer slide to separate it into two parts, I-1 and I-2.

* Please grip the I-1 part while sliding the I-2 part.

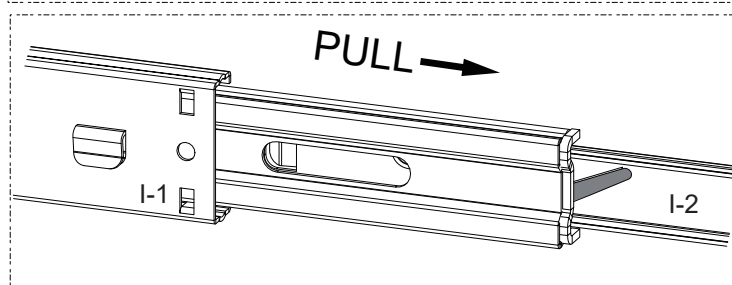
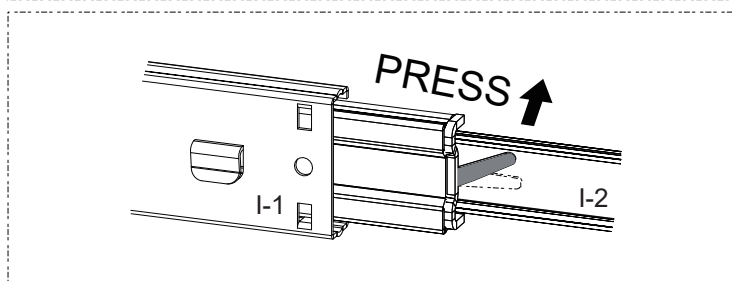
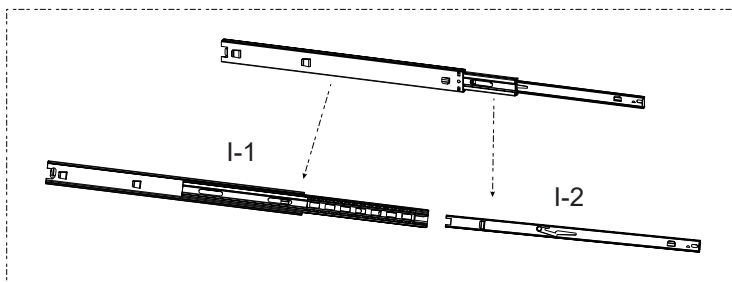

Please scan this QR code to access the video instructions on how to install the three-section slide rail.



Please scan this QR code to access the video instructions on how to install components such as the cam lock and the cam bolt.

"A & B" Hardware installation example

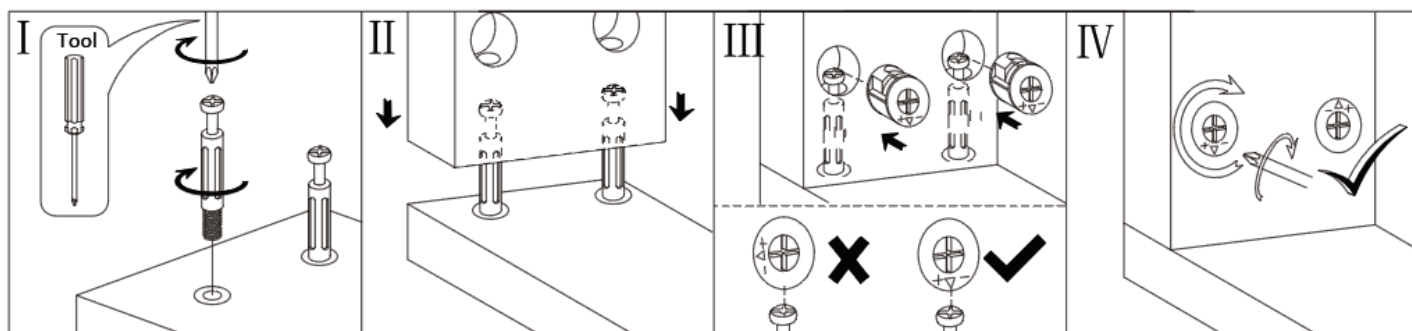

ASSEMBLY STEPS

A x 17

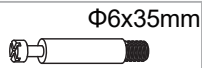

E x 6

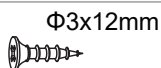

H x 3



STEP 1

1. Fix the cam bolt (A) to the panels (1), (6), (12).
2. Fix the handle (H) to the panels (12) with screw (E).

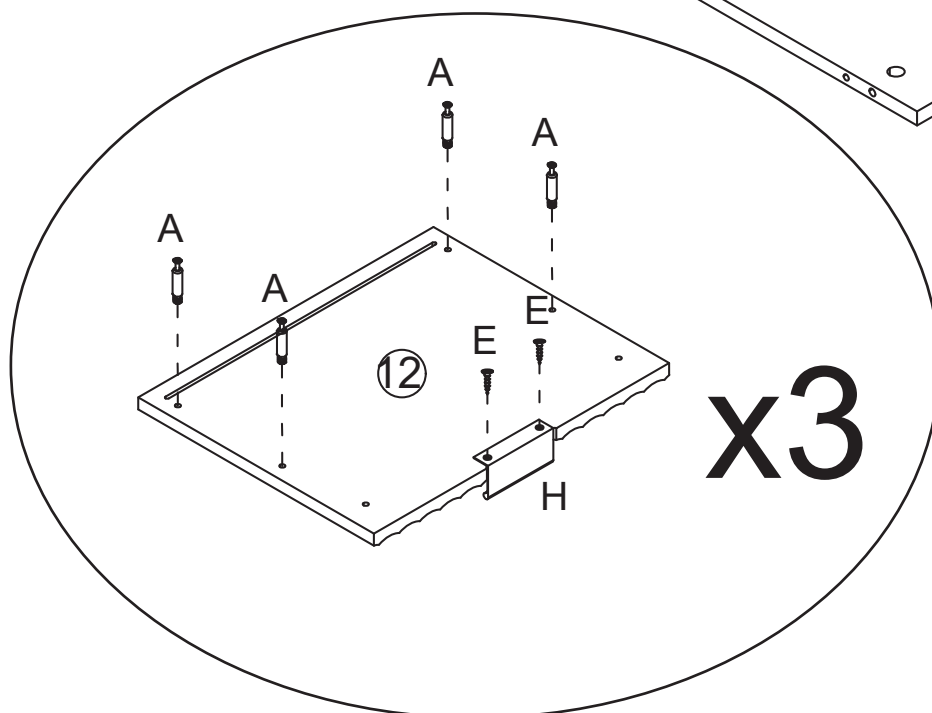
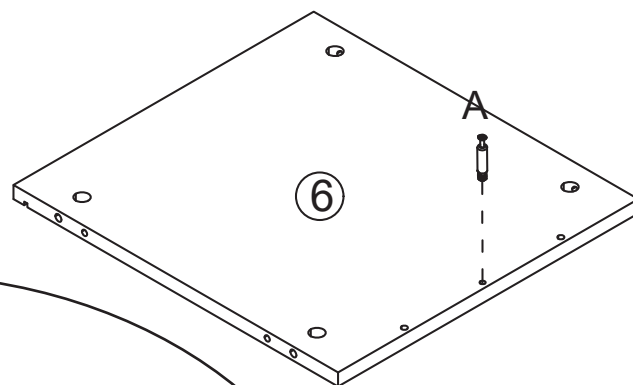
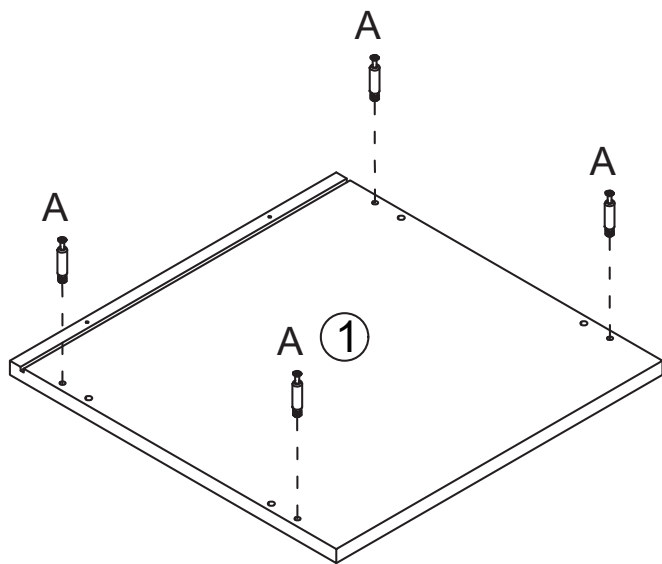

ASSEMBLY STEPS

A x 18



E x 18

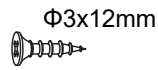

I x 6



STEP 2

1. Fix the three-section drawer slide (I-1) to the panels (2), (5) with screw (E).
2. Fix the cam bolt (A) to the panels (2), (5).

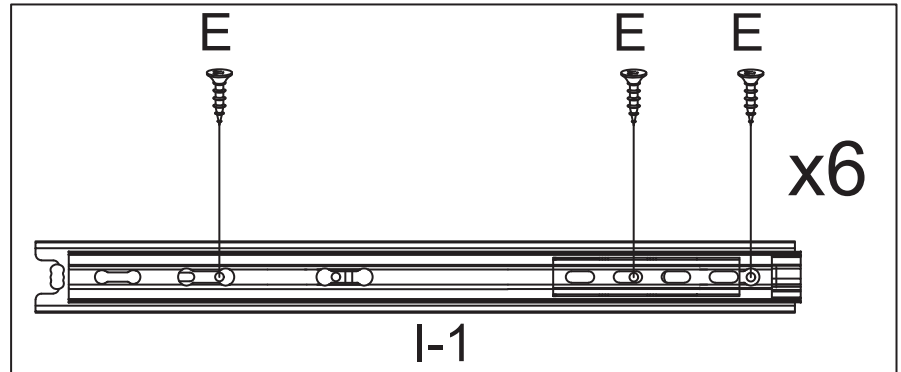

Pay attention to the direction of the slide rail.

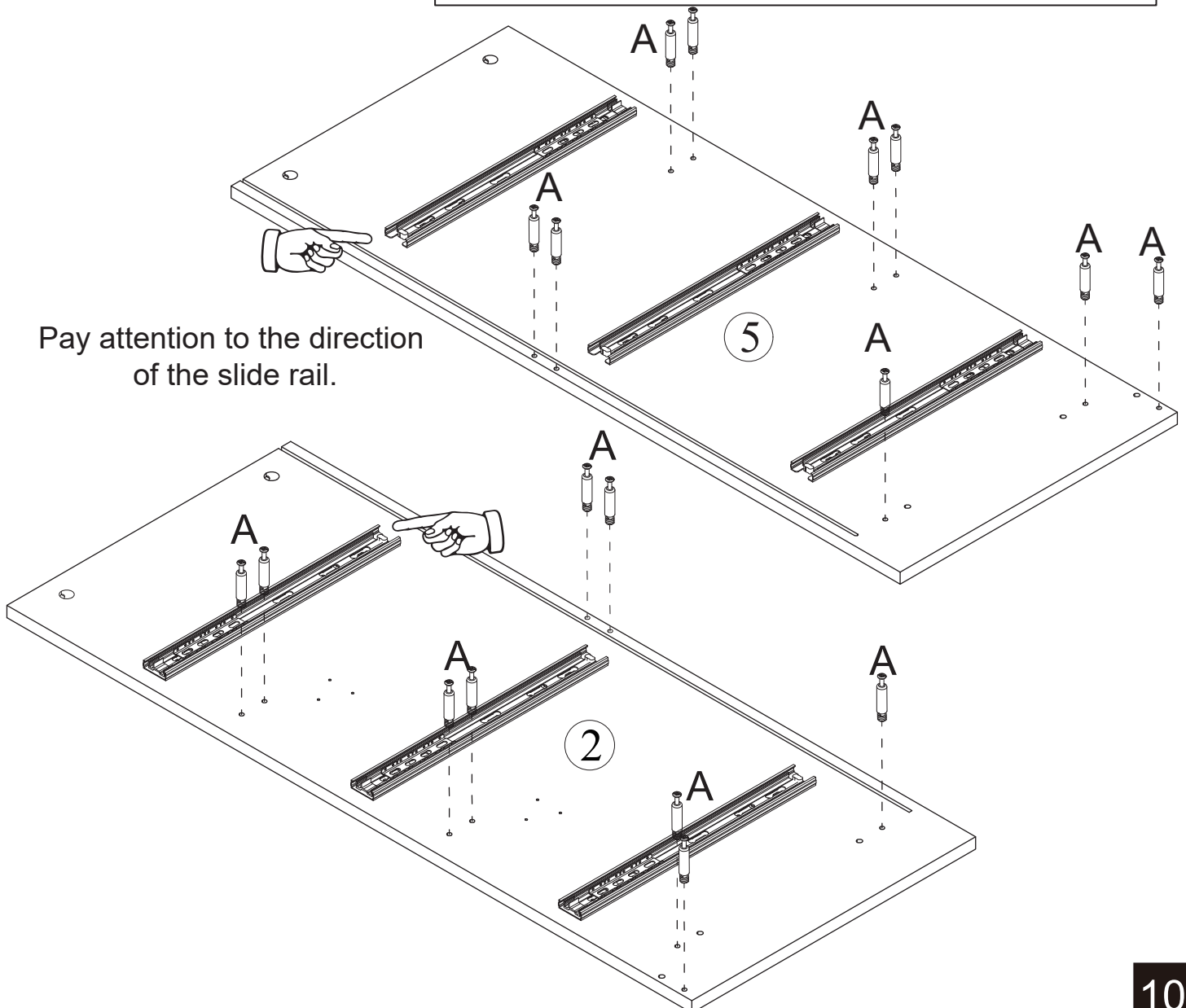

ASSEMBLY STEPS

| | | | | | |
|-------|--|-------|--|-------|--|
| C x 6 |  $\Phi 6 \times 30 \text{mm}$ | N x 6 |  $\Phi 3 \times 16 \text{mm}$ | F x 2 | F-1  |
|-------|--|-------|--|-------|--|

STEP 3

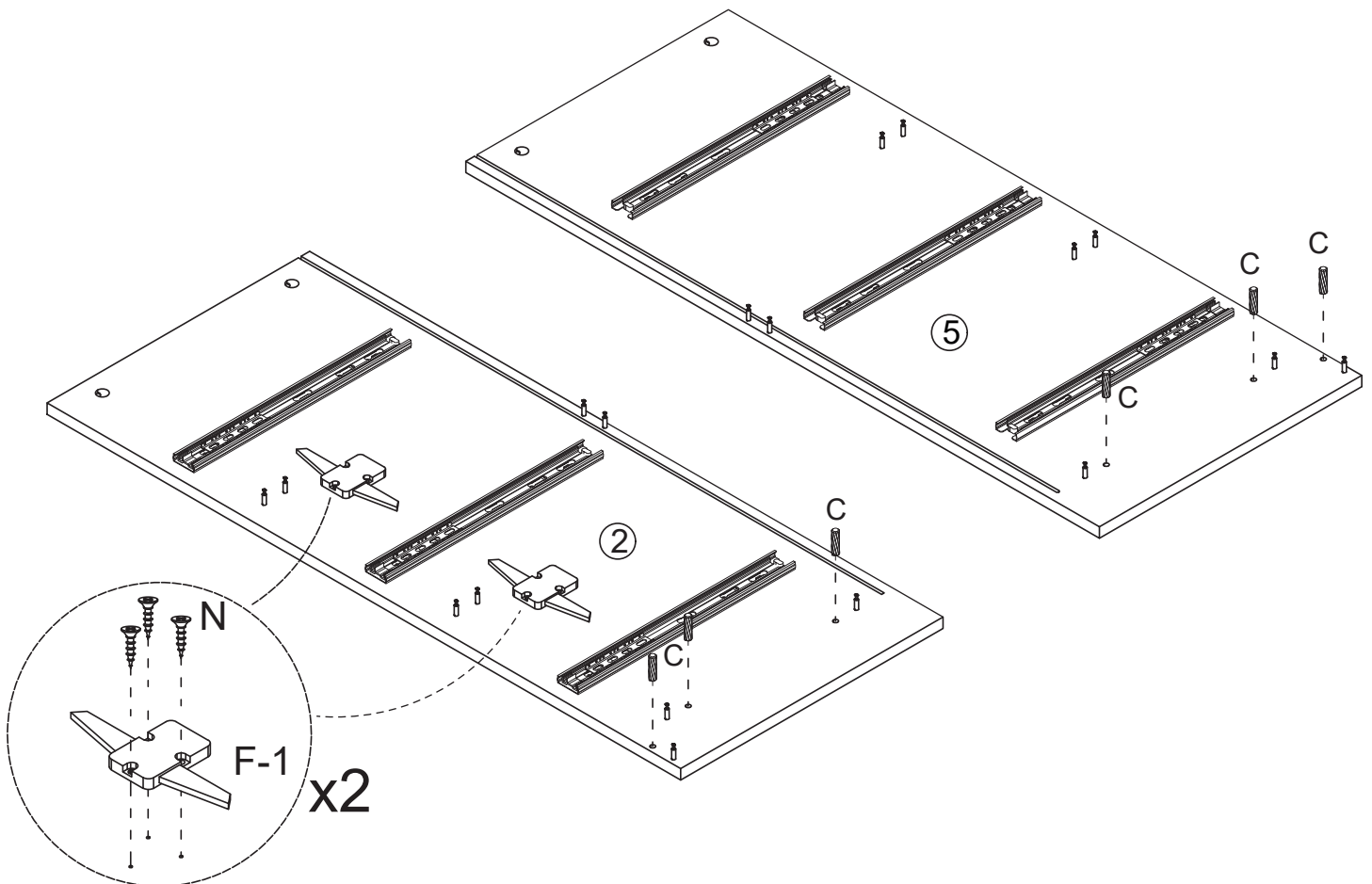

1. Fix the wood dowel (C) to the panels (2), (5).
2. Fix the anti-tip component (F-1) to the panel (2) with screw (N).



NOTE

The anti-tip component prevents two adjacent drawers from being opened simultaneously. This is not a product defect.

ASSEMBLY STEPS

| | | | |
|-------|--|-------|---|
| B x 1 | $\Phi 15 \times 10 \text{mm}$  | C x 2 | $\Phi 6 \times 30 \text{mm}$  |
|-------|--|-------|---|

STEP 4

Connect panels (6), (7) with the wood dowel (C), then tighten with cam lock (B).

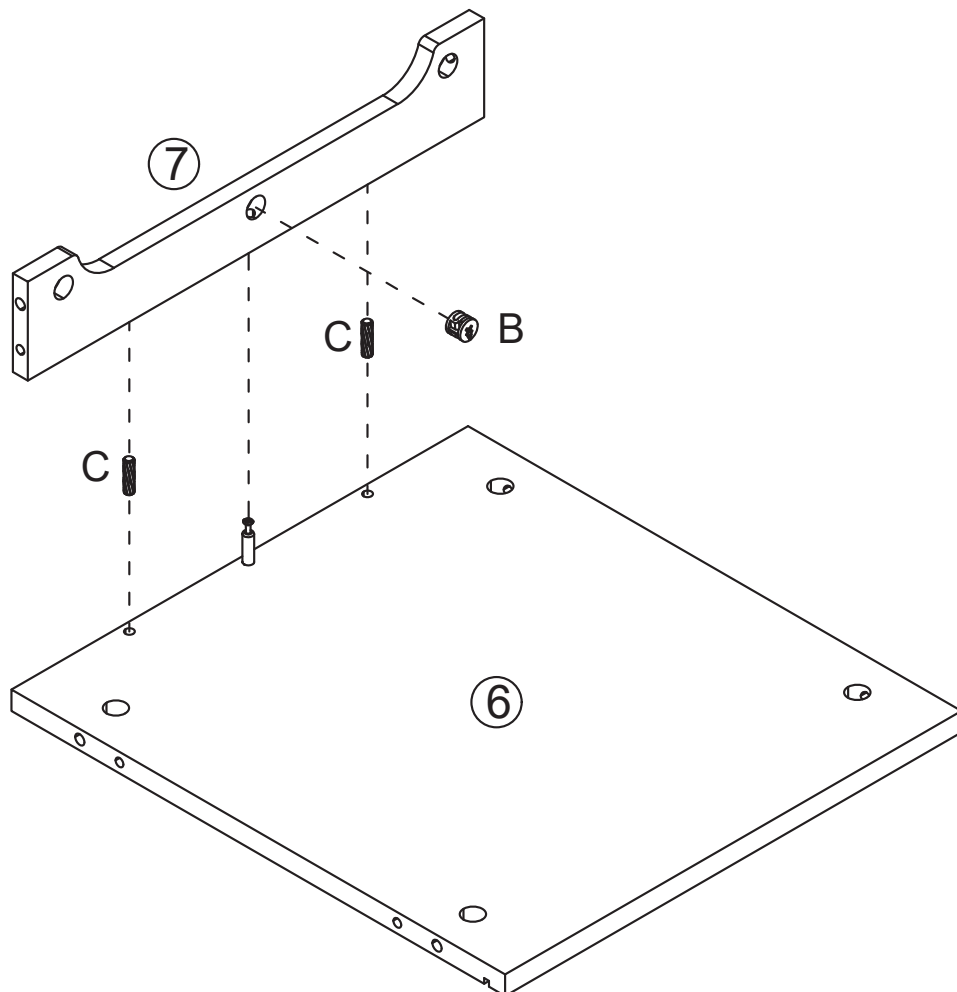

ASSEMBLY STEPS

E x 15

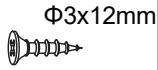

F x 3

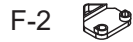

I x 2



STEP 5

1. Fix the anti-tip component (F-2) to the panels (8), (13) with screw (E).
2. Fix the three-section drawer slide (I-2) to the panels (8), (13) with screw (E).

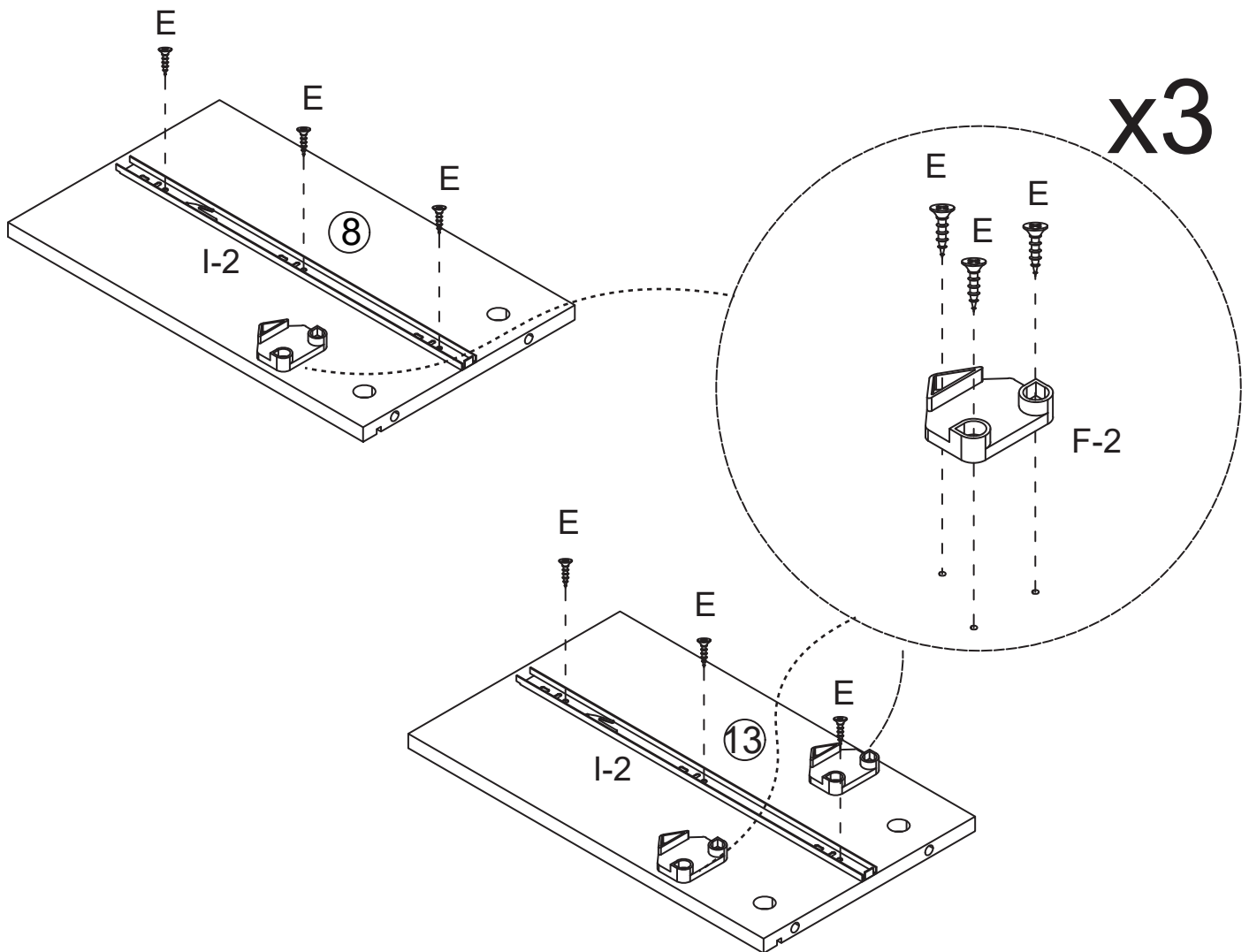

ASSEMBLY STEPS

| | | | | | |
|--------|---|-------|---|-------|--|
| E x 15 | $\Phi 3 \times 12 \text{mm}$  | F x 1 | F-2  | I x 4 | I-2  |
|--------|---|-------|---|-------|--|

STEP 6

1. Fix the anti-tip component (F-2) to the panel (14) with screw (E).
2. Fix the three-section drawer slide (I-2) to the panels (9), (14) with screw (E).

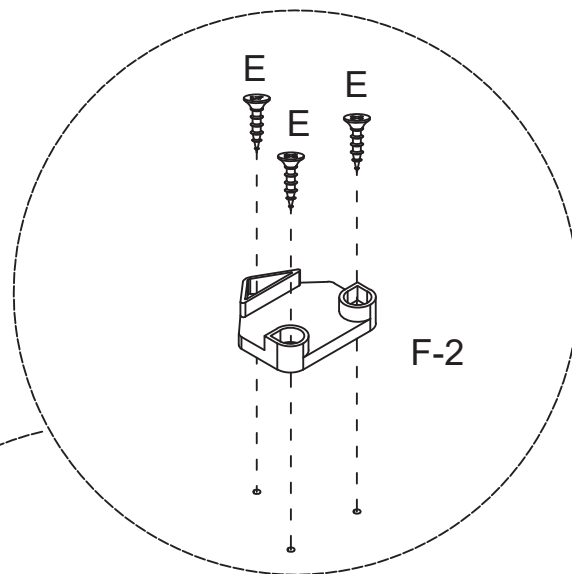
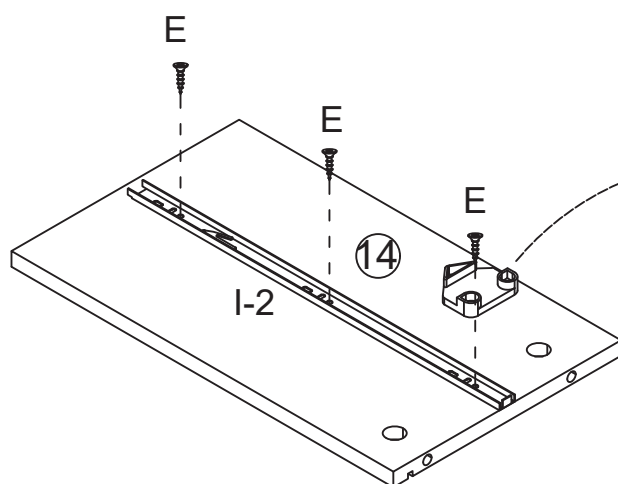
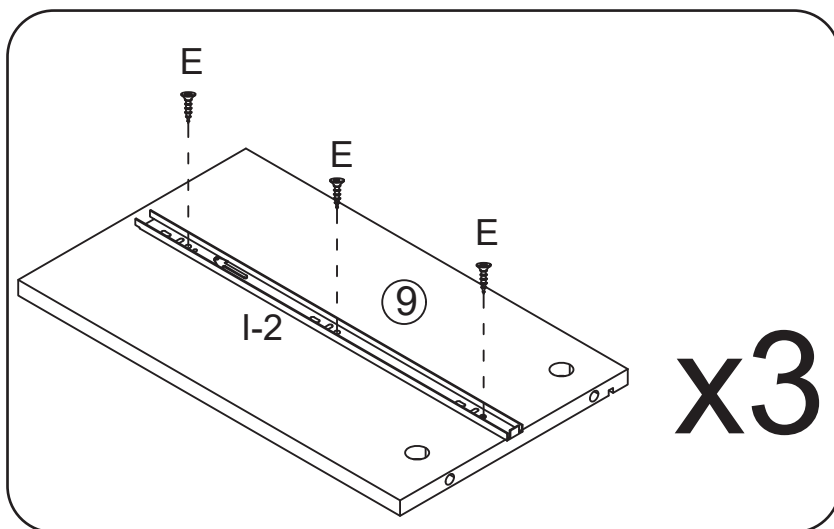

ASSEMBLY STEPS

D x 4



STEP 7

1. Connect panels (9), (10), (14), then tighten them with screw (D).
2. Insert panel (11) along the grooves of panels (9), (14).

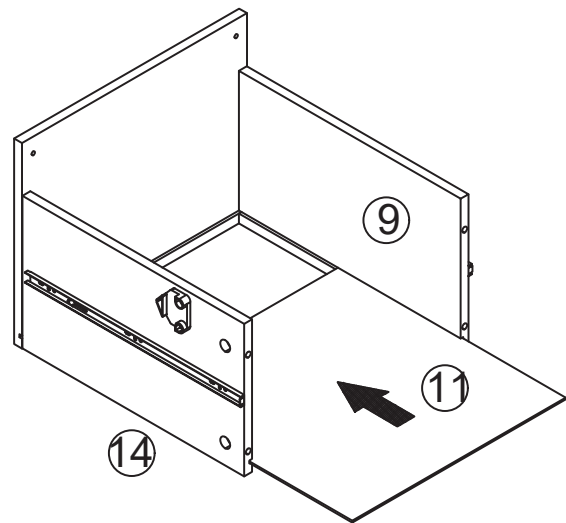
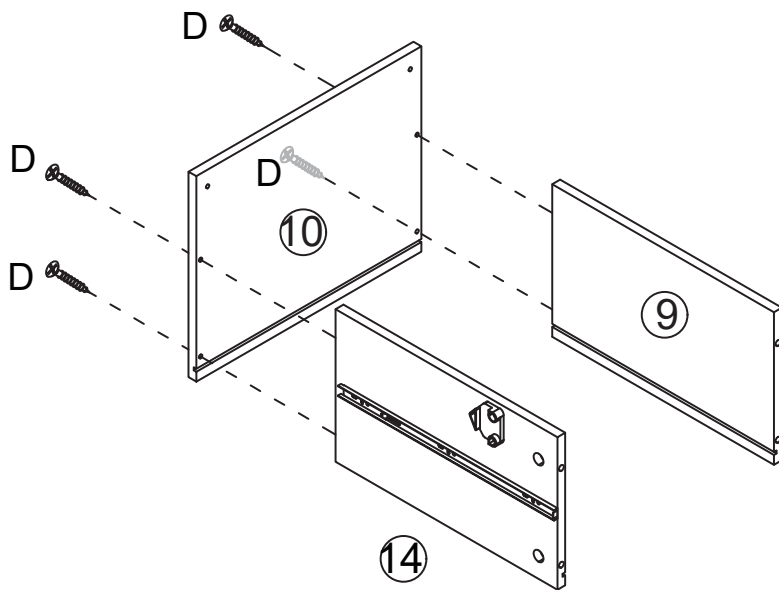

ASSEMBLY STEPS

| | | | |
|-------|--|-------|---|
| B x 4 | $\Phi 15 \times 10 \text{mm}$  | G x 2 |  |
|-------|--|-------|---|

STEP 8

Connect panels (9), (12), (14) and hanging rod (G), then tighten them with cam lock (B).

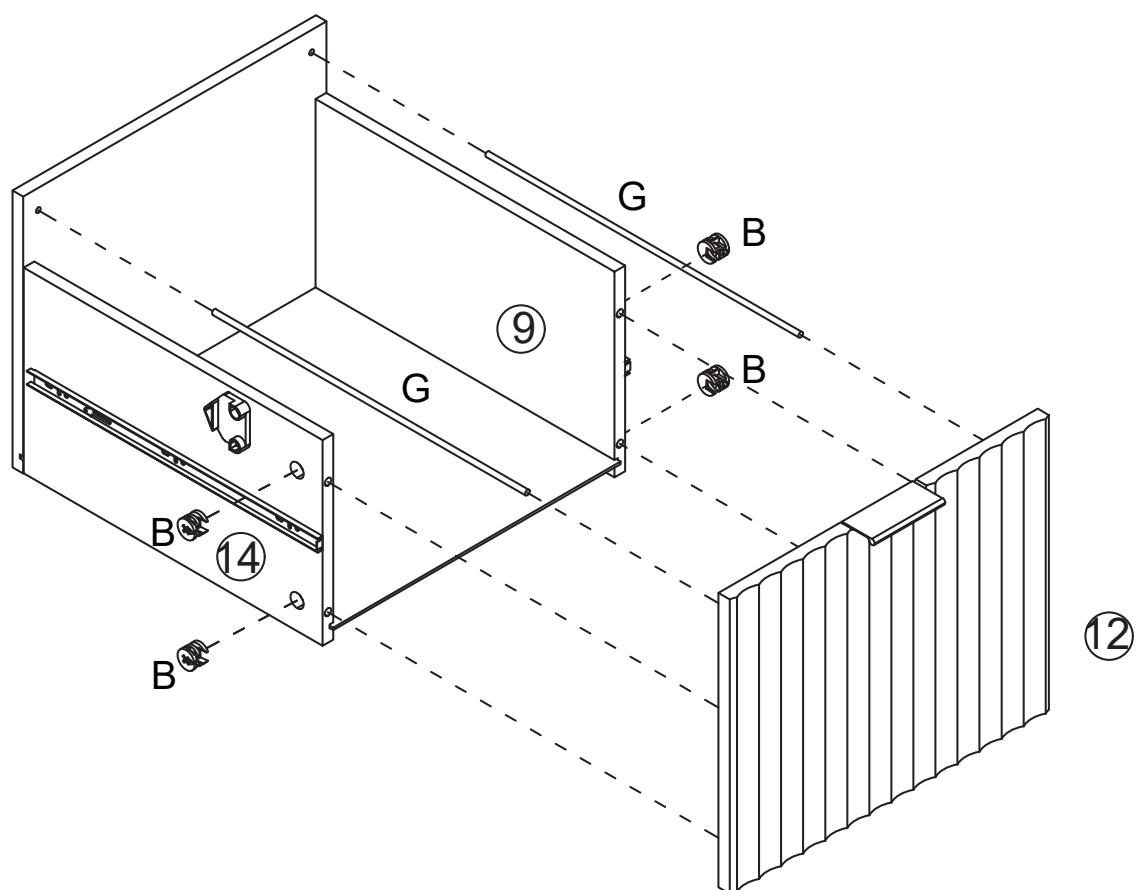

ASSEMBLY STEPS

D x 4



STEP 9

1. Connect panels (9), (10), (13), then tighten them with screw (D).
2. Insert panel (11) along the grooves of panels (9), (13).

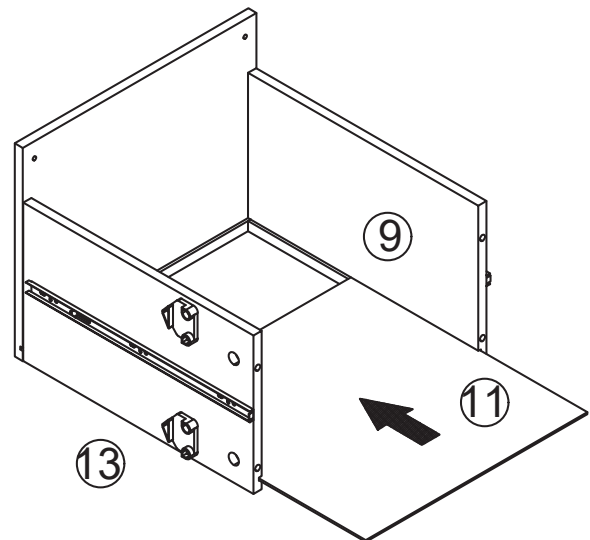
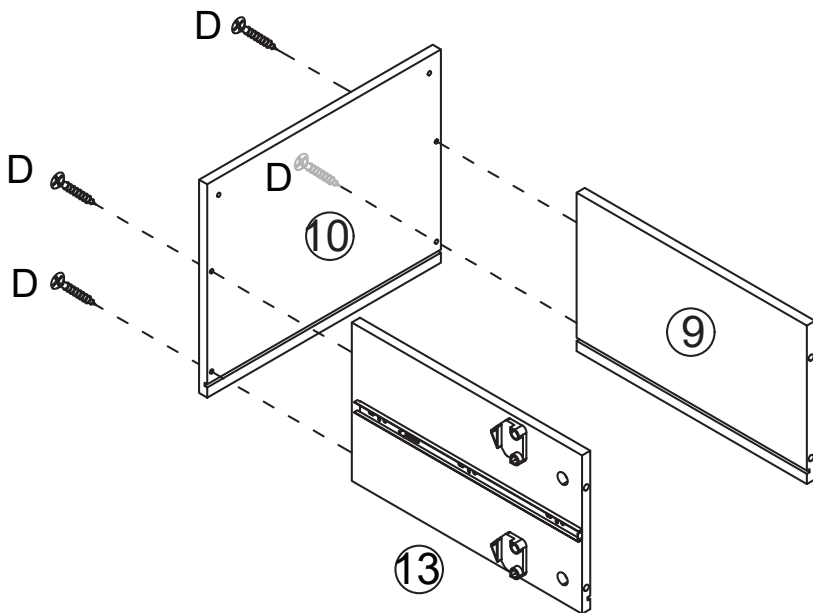

ASSEMBLY STEPS

| | | | |
|-------|--|-------|---|
| B x 4 | $\Phi 15 \times 10 \text{mm}$  | G x 2 |  |
|-------|--|-------|---|

STEP 10

Connect panels (9), (12), (13) and hanging rod (G), then tighten them with cam lock (B).

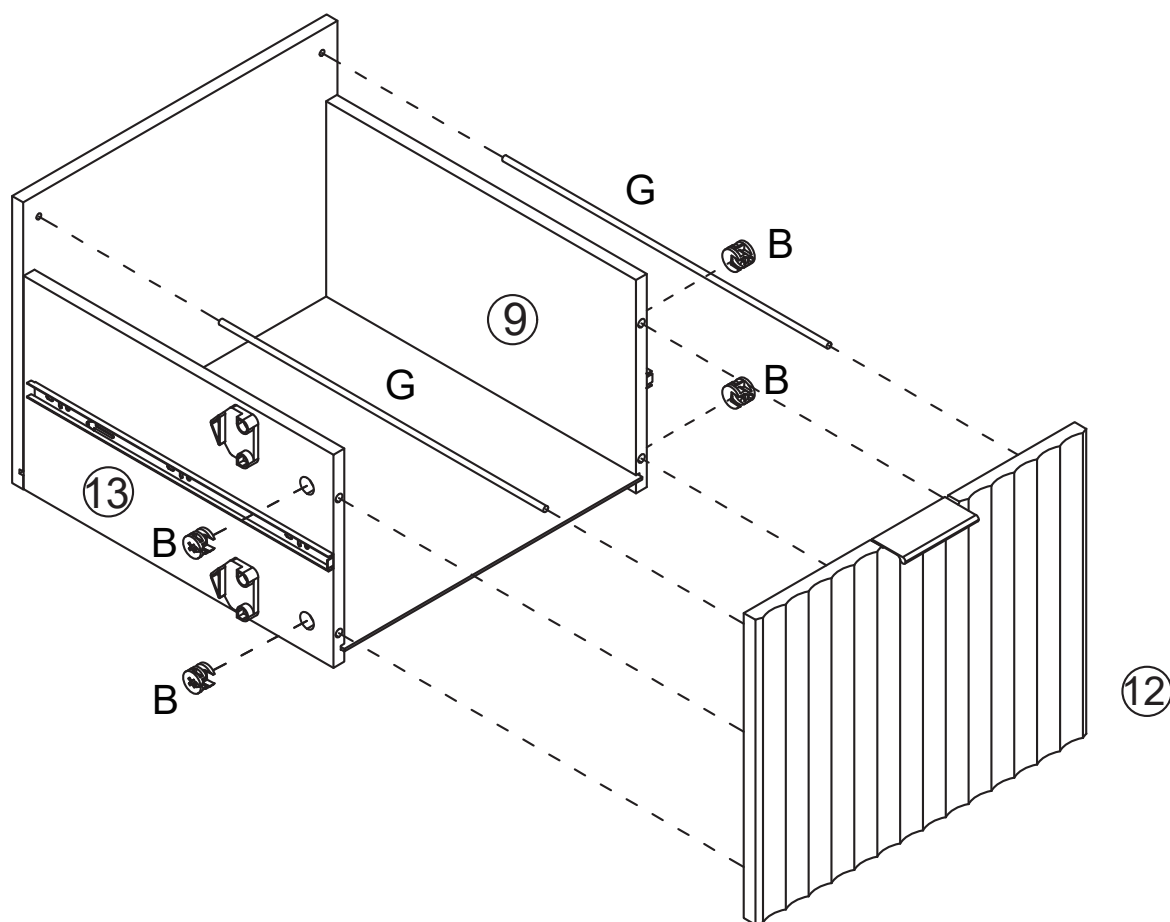

ASSEMBLY STEPS

D x 4



STEP 11

1. Connect panels (8), (9), (10), then tighten them with screw (D).
2. Insert panel (11) along the grooves of panels (8), (9).

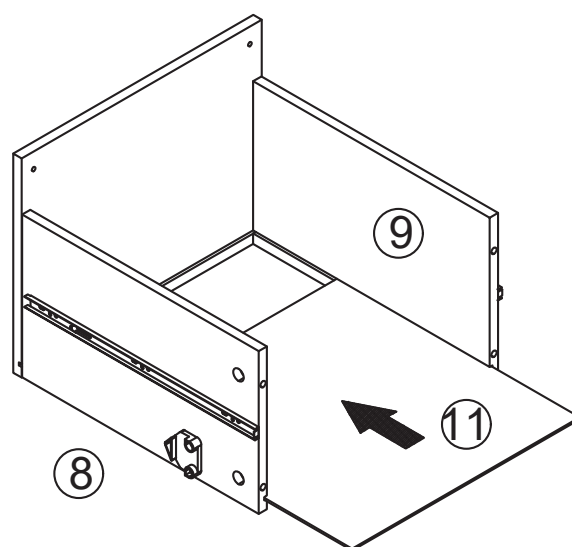
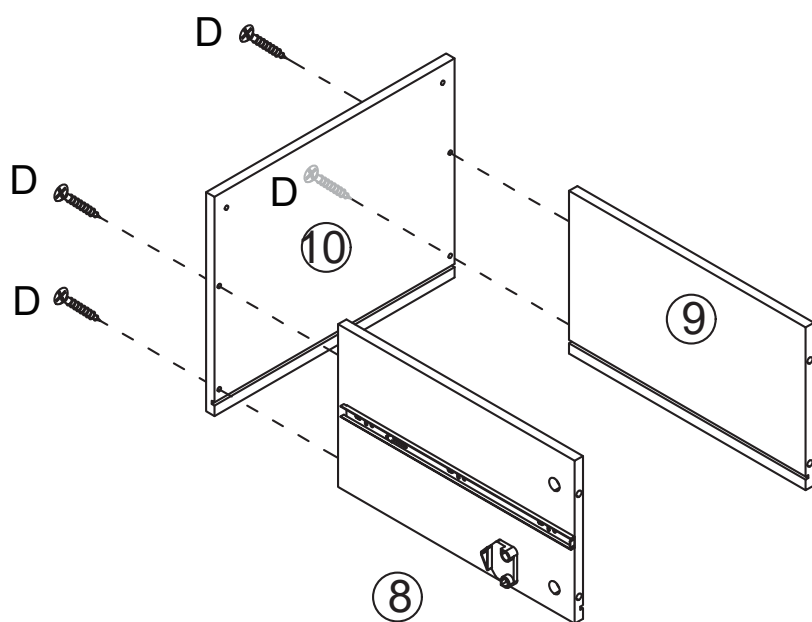

ASSEMBLY STEPS

| | | | |
|-------|--|-------|---|
| B x 4 | $\Phi 15 \times 10 \text{mm}$  | G x 2 |  |
|-------|--|-------|---|

STEP 12

Connect panels (8), (9), (12) and hanging rod (G), then tighten them with cam lock (B).

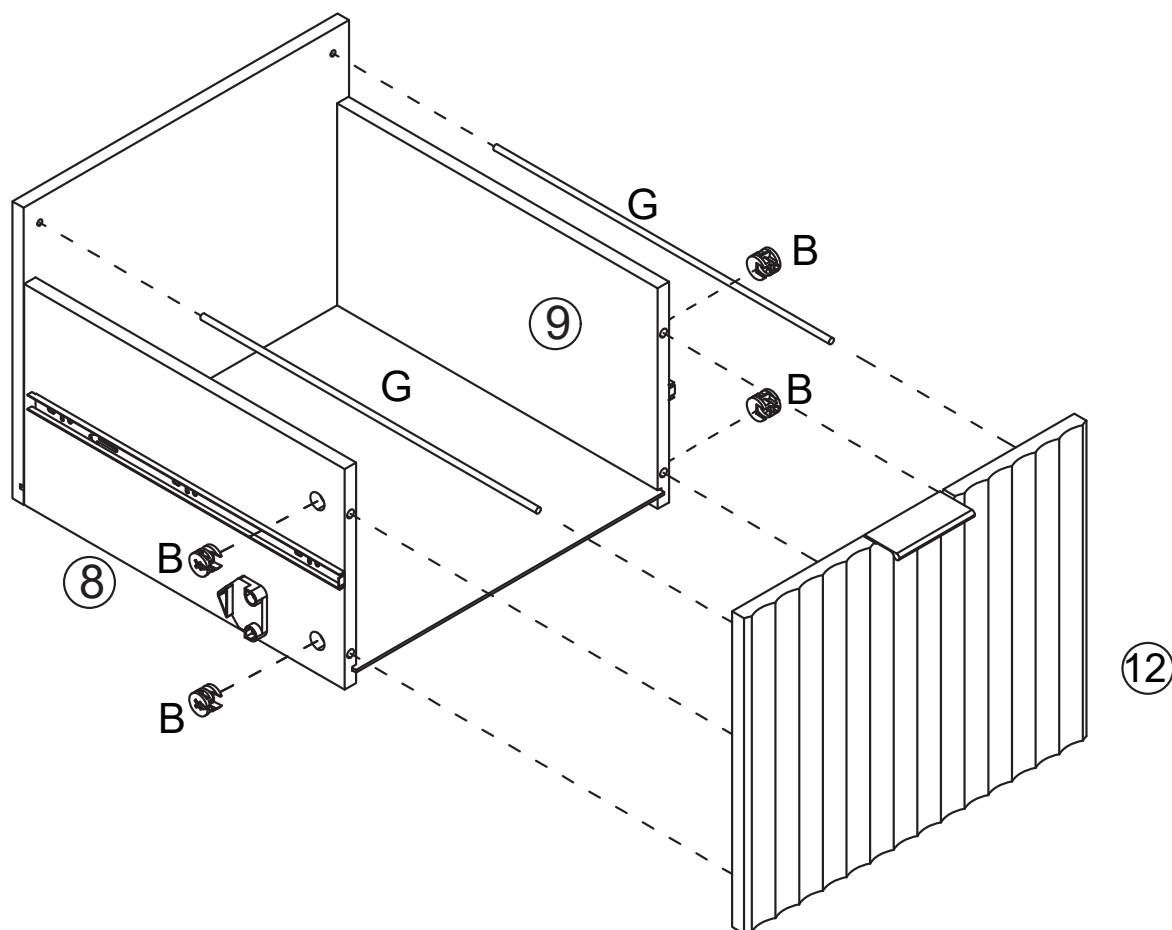

ASSEMBLY STEPS

B x 9

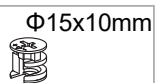

STEP 13

Connect panels (2), (6) and wood strips (4), then tighten them with cam lock (B).

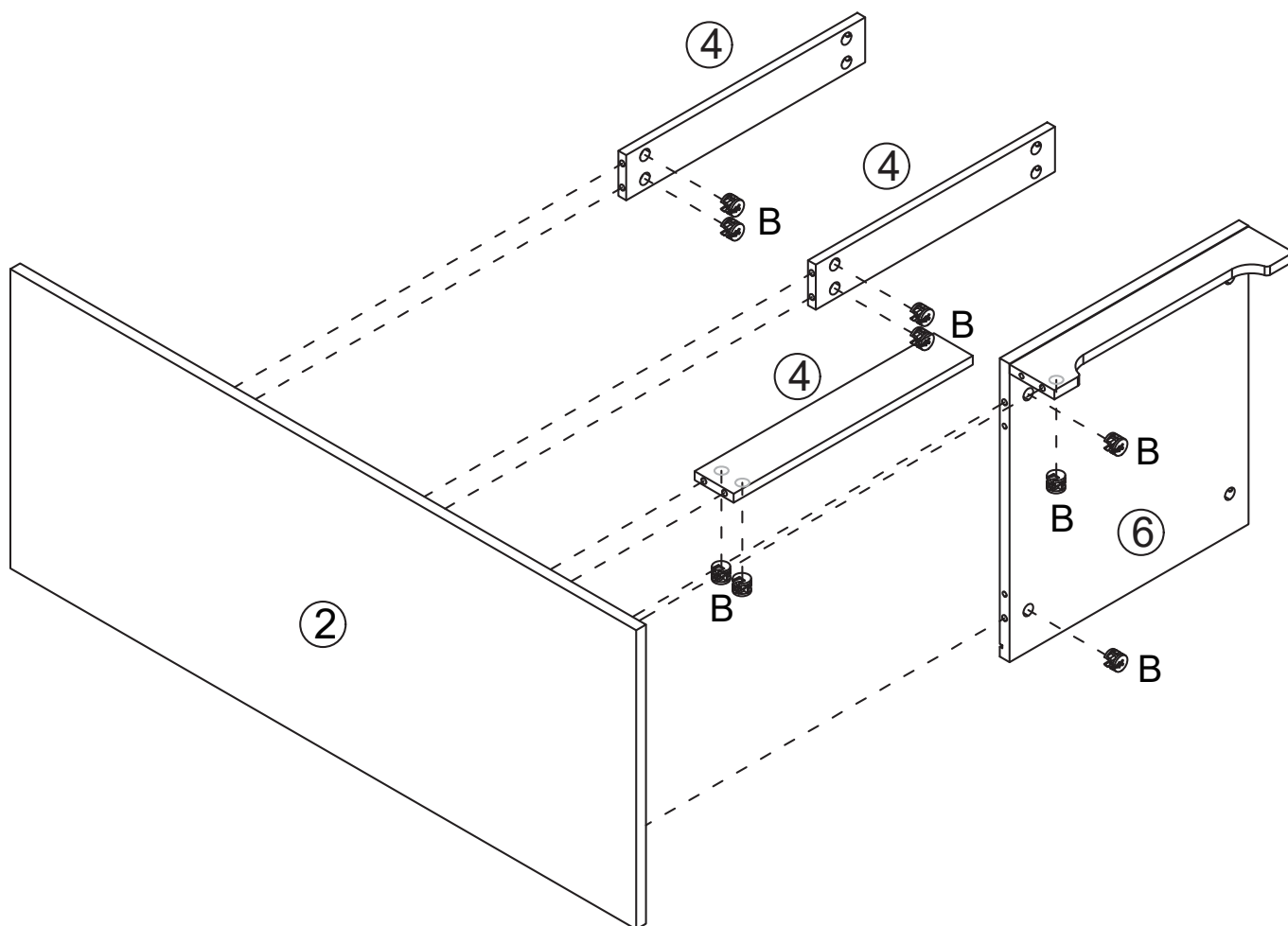

ASSEMBLY STEPS

B x 9

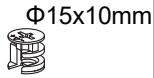

M x 4



STEP 14

1. Connect panel (5) to the assembled frame (STEP 13), then tighten them with cam lock (B).
2. Stick the foot pad (M) onto the bottom of panels (2), (5).

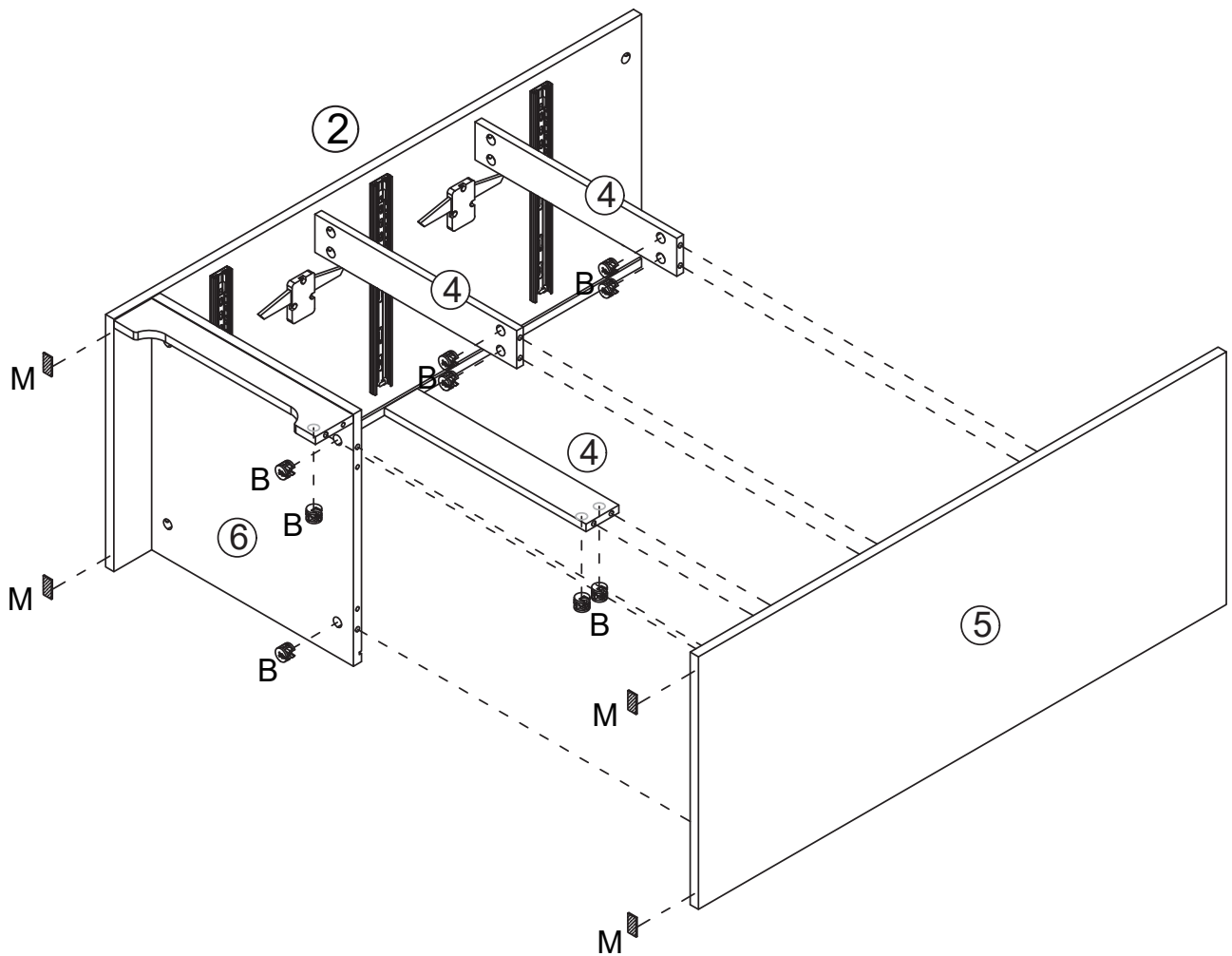

ASSEMBLY STEPS

STEP 15

Insert panel (3) along the grooves of panels (2), (5).

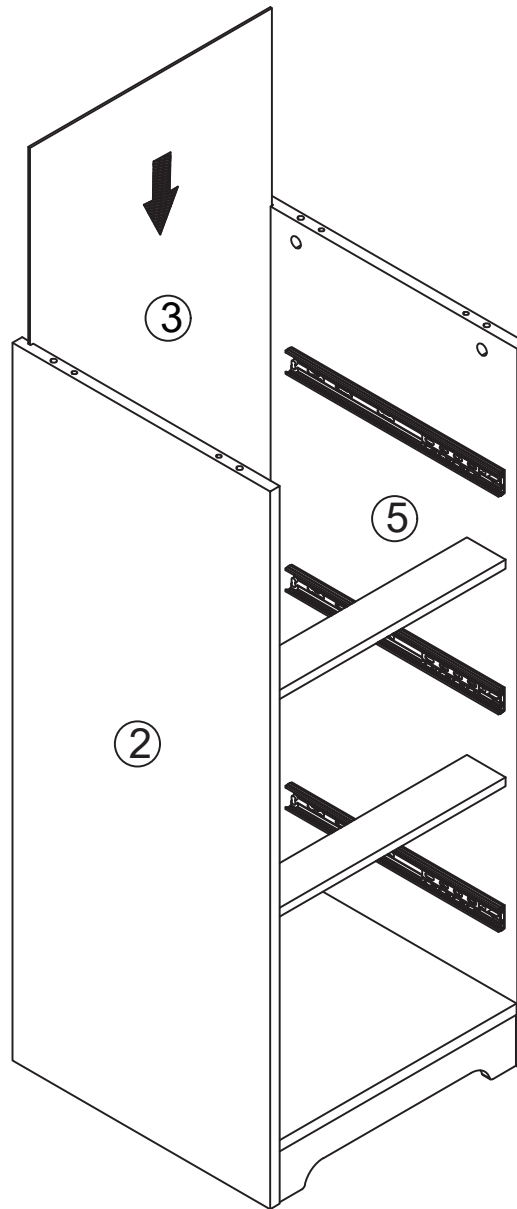

ASSEMBLY STEPS

B x 4

Φ15x10mm



C x 4

Φ6x30mm



STEP 16

Connect the panel (1) to the assembled frame (STEP 15) with the wood dowel (C), then tighten with cam lock (B).

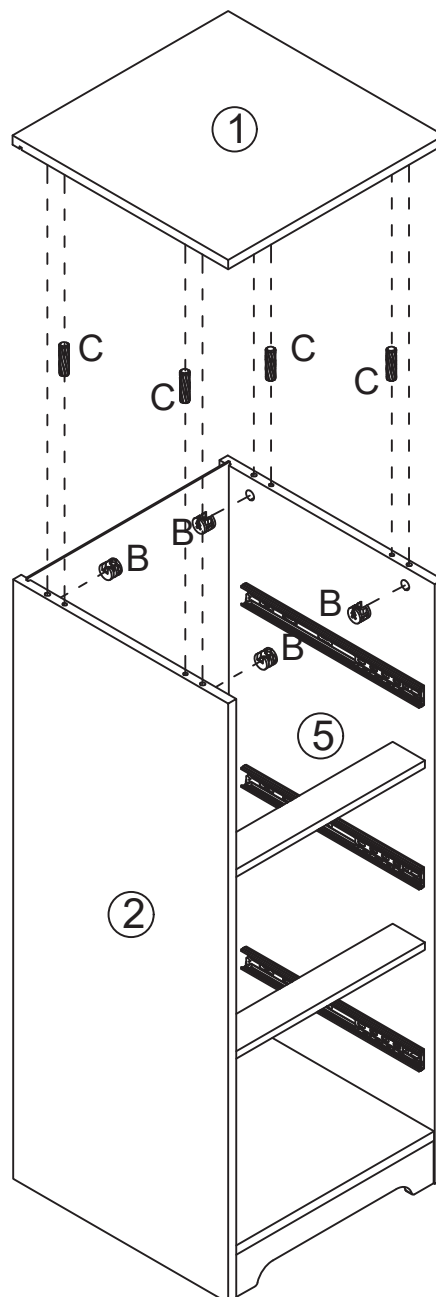

ASSEMBLY STEPS

| | | | | | | |
|-------|---|---|-------|---|---|---|
| K x 8 | K-1  | $\Phi 3 \times 16 \text{mm}$ K-2  | L x 2 | L-1  | $\Phi 4 \times 12 \text{mm}$ L-2  | L-3  |
|-------|---|---|-------|---|---|---|

STEP 17

1. Insert the back panel wedge (K-1) into the gap of cabinet back panel and tighten them with screw (K-2).
2. Use screw (L-3) to pass through washer (L-2) and fix the anti-tipping strap (L-1) to panel (1).

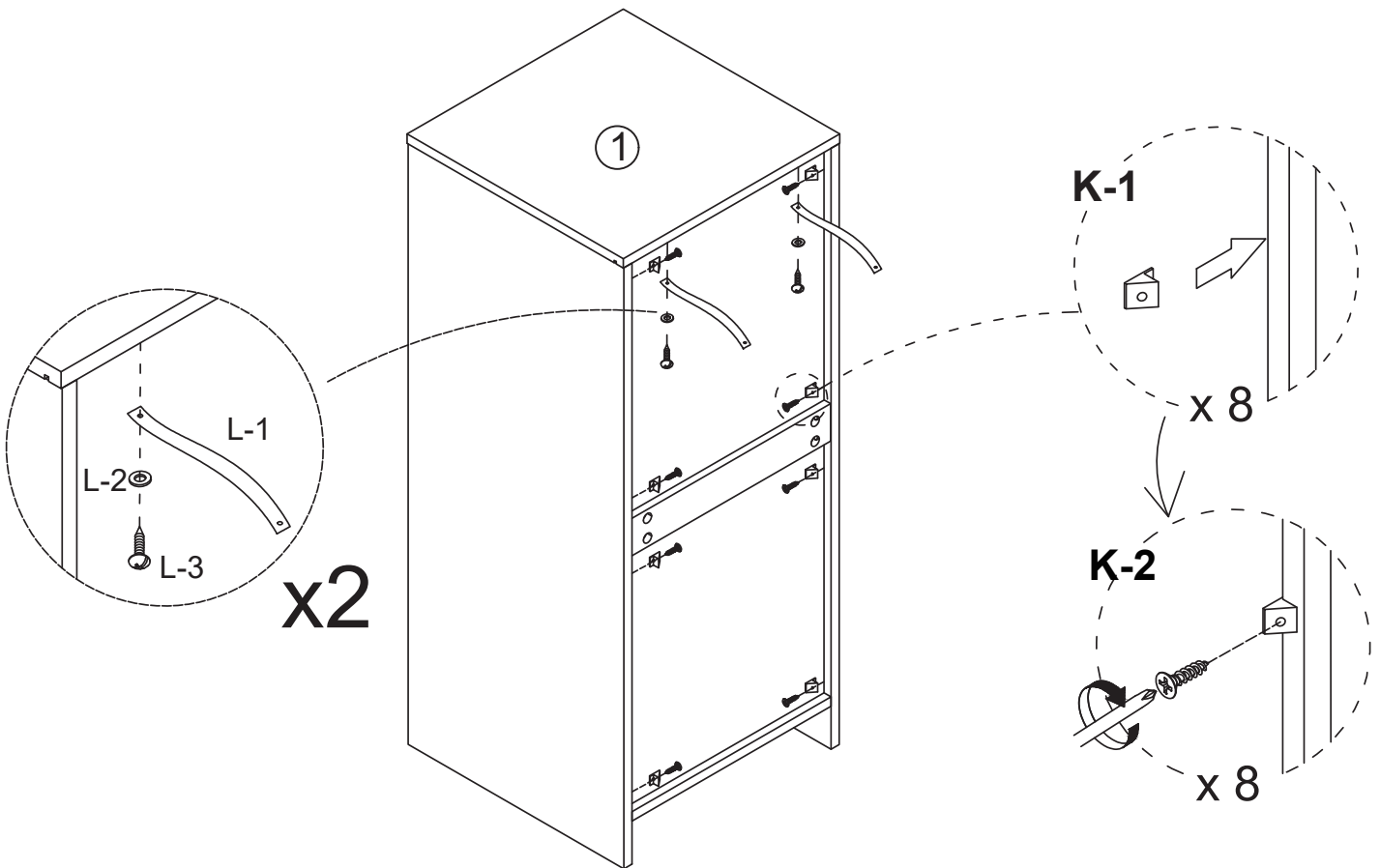

ASSEMBLY STEPS

STEP 18

Align the slides on the drawer and cabinet, and then gently push the drawer into the cabinet.

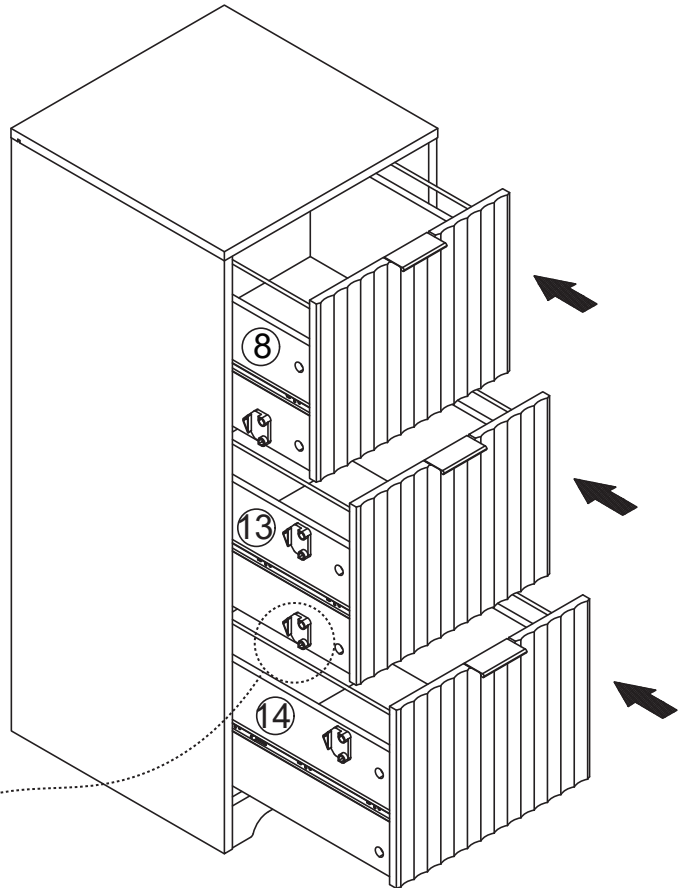
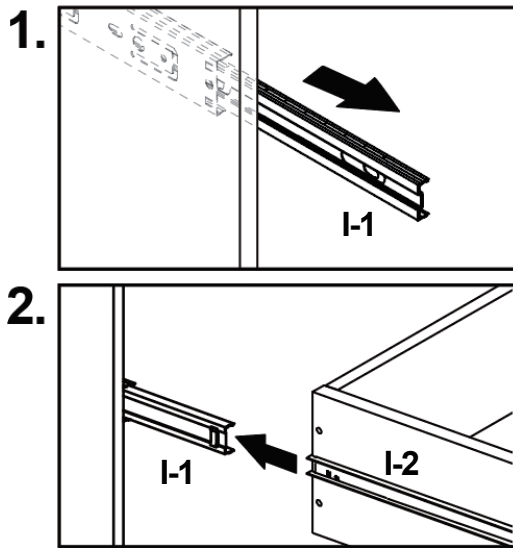

NOTE

The anti-tip component prevents two adjacent drawers from being opened simultaneously. This is not a product defect.

Drawer Disassembly

If you need to remove the drawer, lift the lever on the left side slide upward and push down the lever on the right side slide, then slowly pull out the drawer.

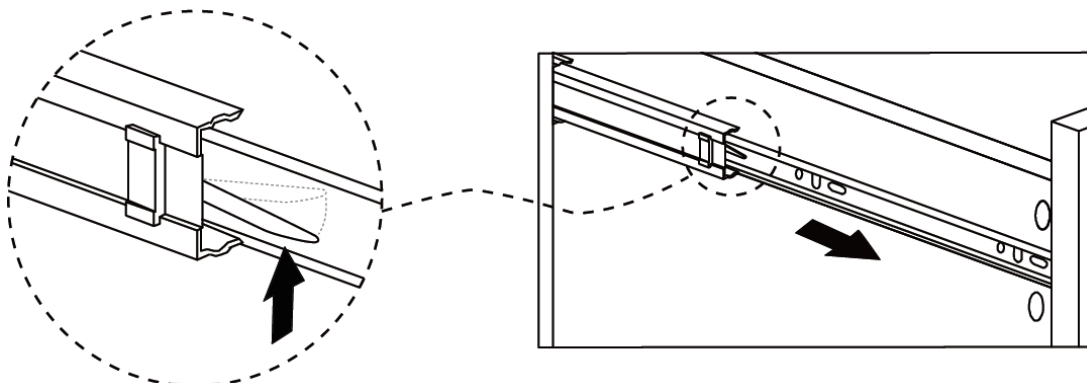

ASSEMBLY STEPS

J x 2

J-1



J-2



J-3



Φ4x45mm

STEP 19

Drill two holes in the wall, embed the plastic anchor (J-1) and then use screw (J-3) to pass through the washer (J-2) to fix the cabinet on the wall.

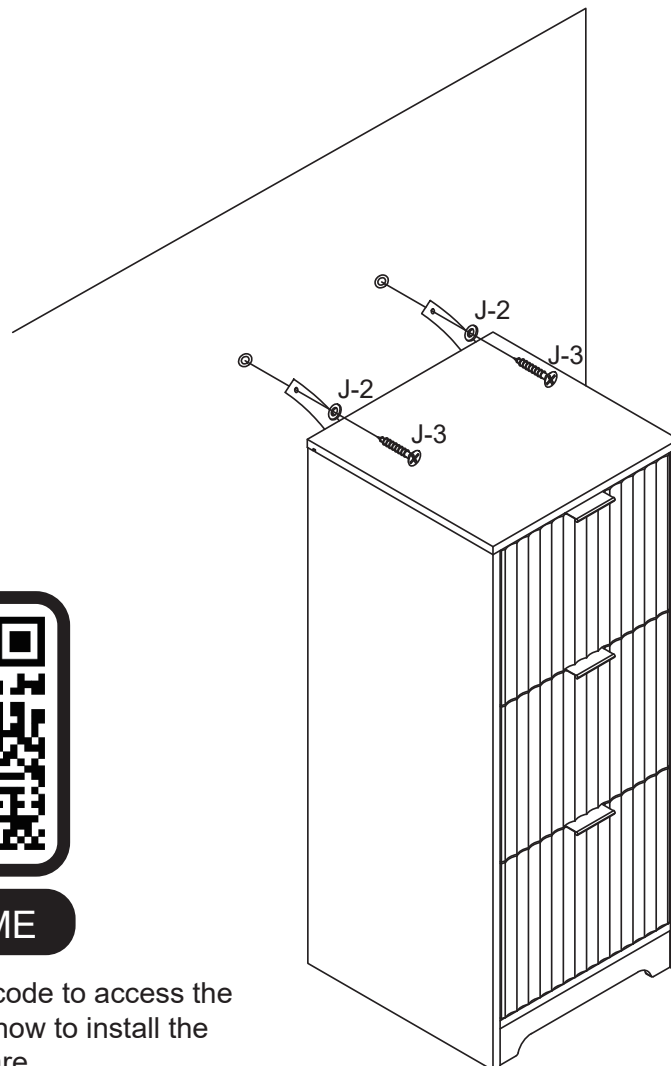
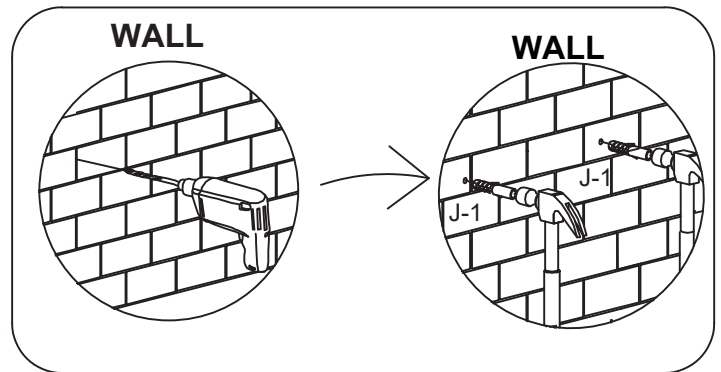

SCAN ME

Please scan this QR code to access the video instructions on how to install the wall-mounting hardware

1. What should I do when I received a defected item?

Please feel free to contact VINGLI customer service via the link where you purchased this item with your order ID, pictures of the defective areas to us. We are eager to help you to make it right.

2. Is it easy to put the screws to the panels?

Yes. As long as you follow the instruction and use the correct screws and put it in correct holes, it is easy to screw it into pre-drilled holes.

3. What should I do if I have a problem with the drawers not closing flush?

The problem with the drawers not closing flush is usually caused by the assembly of the drawer slides. Here are the solutions as below:

1) Please check whether the slide rail is damaged, for example, the ball of the slide rail has fallen out, if so, please ask us for replacements of the drawer slides;

2) Refer to the assembly manual to check if the holes for the slide rail are assembled correctly. If there is no problem with the assembly, but the slide rail is stuck in the process of pushing in, please release the entire drawer as you did the first time you removed the drawer slides, and then push it back in again.

Any query, please contact us directly.

Supplementary Instructions for Safe Use

English

WARNING



Children have died from furniture tipover. To reduce the risk of furniture tipover:

- ALWAYS install tipover restraint provided.
- NEVER put a TV on this product.
- NEVER allow children to stand, climb or hang on drawers, doors, or shelves.
- NEVER open more than one drawer at a time.
- Place heaviest items in the lowest drawers.
- Do not defeat or remove the drawer interlock system.

This is a permanent label.

Do not remove!

French

ATTENTION



Des enfants sont morts du basculement des meubles. Pour réduire le risque de basculement des meubles:

- TOUJOURS installer la retenue de basculement fournie.
- NE JAMAIS mettre de téléviseur sur ce produit.
- NE JAMAIS permettre aux enfants de se tenir debout, de grimper, ou de s'accrocher à des tiroirs, des portes ou des étagères.
- N'ouvrez JAMAIS plus d'un tiroir à la fois.
- Placez les objets les plus lourds dans les tiroirs les plus bas.
- Ne désactivez pas et ne retirez pas le système de verrouillage du tiroir.

Ceci est une étiquette permanente.

Ne pas enlever!

German

WARNUNG



Kinder sind an einem Möbelkipp gestorben. So verringern Sie das Risiko eines Umkippens von Möbeln:

- Installieren Sie **IMMER** die mitgelieferte Kipprückhaltevorrichtung.
- Stellen Sie **NIEMALS** einen Fernseher an dieses Produkt.
- Lassen Sie Kinder **NIEMALS** an Schubladen, Türen oder Regalen stehen klettern oder hängen.
- Öffnen Sie **NIEMALS** mehr als eine Schublade gleichzeitig.
- Legen Sie schwerste Gegenstände in die untersten Schubladen.
- Besiegen oder entfernen Sie das Schubladenverriegelungssystem nicht.

Dies ist ein dauerhaftes Etikett.

Nicht entfernen!



WARNING

This product can expose you to chemicals including Formaldehyde (gas), which is known to the State of California to cause cancer. For more information go to www.P65Warnings.ca.gov.