

ASSEMBLY INSTRUCTION / INSTRUCTION D'ASSEMBLAGE

1/-3CK / DW CK KING BED / Calif. Tres Grand Lit
1 King Headboard & Footboard / Tête de Lit & Pied de Lit
3 CK CK Side Rails, Slats & Support Legs Longerons ,

Pieds de Lit et Latte

Footboard Drawer / Tiroir de pied de lit

Thank you for purchasing this product. Please take time to read and follow the instructions below. Check that you have all parts and hardware before assembly. Parts apparently missing are often found in the packing materials. If you do not have all the parts listed, have your dealer contact us and they will be sent to you immediately.



It is recommended to install protective pads under all legs and supports to avoid damage or scratches when placing furniture on a wood floor or other hard surface, and to limit indentation and prevent discoloration if placing on carpet.

Merci d'avoir acheté ce produit de qualité. Vérifiez avant le montage que vous avez toutes les pièces et fixations. Les pièces qui semblent manquer se trouvent souvent dans les matériaux d'emballage. Si vous n'avez pas toutes les pièces de la liste, demandez à votre détaillant et nous vous les enverrons immédiatement



Il est recommandé de placer des coussins protecteurs sous tous les pieds et toutes les bases des meubles pour éviter d'endommager ou d'égratigner les planchers en bois ou autres surfaces dures, et pour limiter l'empreinte et empêcher la décoloration quand les meubles reposent sur la moquette.

PART LIST/ LISTE DE PIECE			
NO	COMPONENT	SKETCH	QTY
D	SIDE RAIL / LONGERONS		2 PCS
E	CENTER SLAT DRAWER SUPPORT/SUPPORT DE TIROIR CENTRAL		1 PC
F	BED SLAT / LATTES		3 PCS
G	BED SLAT SUPPORT / LATTES SOUTIEN		8 PCS
H	DRAWER SLAT SUPPORT/ SUPPORT DE LAMES DE TIROIR		1 PC
I	CONCEALED PANEL/PANNEAU CACHÉ		4 PCS
J	DRAWER SUPPORT RAIL/RAIL DE SUPPORT DE TIROIR		2 PCS
K	BED SLAT WITH STOPPER / LATTE DE LIT AVEC BOUCHON		2 PCS
L	DRAWER/TIROIR		2 PCS
M	CONCEALED PANEL(WITH TOP CROWN)/ PANNEAU CACHÉ (AVEC LA COURONNE SUPÉRIEURE)		2 PCS

HARDWARE LIST / LISTE DE QUINCAILLERIE				
NO	DESCRIPTION	SKETCH	SIZE	QTY
5	CSK SCREW / VIS		M4 x 32MM	14 PCS
6	PAN HEAD SCREW / VIS À TÊTE DE PANNEAU		M3.5 x 20MM	30 PCS
7	JCBC BOLT/ BOULON		M6 x 35MM	2 PCS
8	JCBC BOLT/ BOULON		M6 x 50MM	9 PCS
9	SPRING WASHER/ RONDELLE D' ARRÊT		1/4" x 2mm(Thickness)	2 PCS
10	FLAT WASHER/ RONDELLE PLATE		1/4" ID x 13mm x 1mm(Thickness)	2 PCS
11	ALLEN KEY / CLÉ ALLEN		M4 x 65mm	1 PC
12	ALLEN KEY / CLÉ ALLEN		M5 x 65mm	1 PC

*HARDWARE SETS ARE IN 1505K - 3CK

NOTE : MUST TIGHTEN SCREWS PERIODICALLY WITH USE SCREW WILL BECOME LOOSE CHECK TIGHTNESS OF ALL SCREW EVERY 6-8 WEEKS. REMARQUE: DOIT SERRER LES VIS PÉRIODIQUEMENT AVEC LA VIS D'UTILISATION DEVIENDRA PERDRE VÉRIFIER LE SERRAGE DE TOUTES LES VIS Toutes les 6-8 semaines.

DO NOT TIGHTEN BOLTS UNTIL COMPLETELY ASSEMBLED.
NE PAS SERRER LES BOULON JUSQU'A CE QUE LE MONTAGE SOIT COMPLETMENT TERMINE

PAGE 1 OF 4 /
PAGE 1 DE 4

STEP 1 / ÉTAPE 1 :

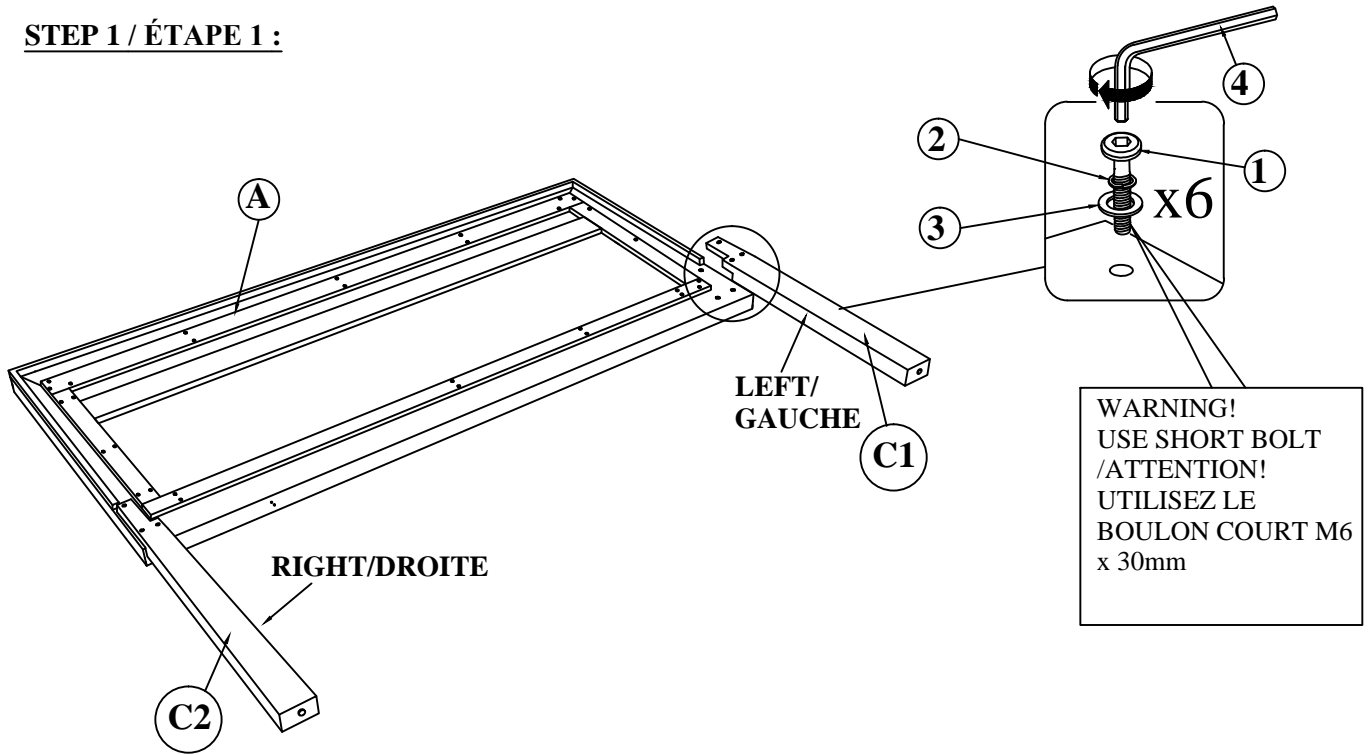

STEP 2 / ÉTAPE 2 :

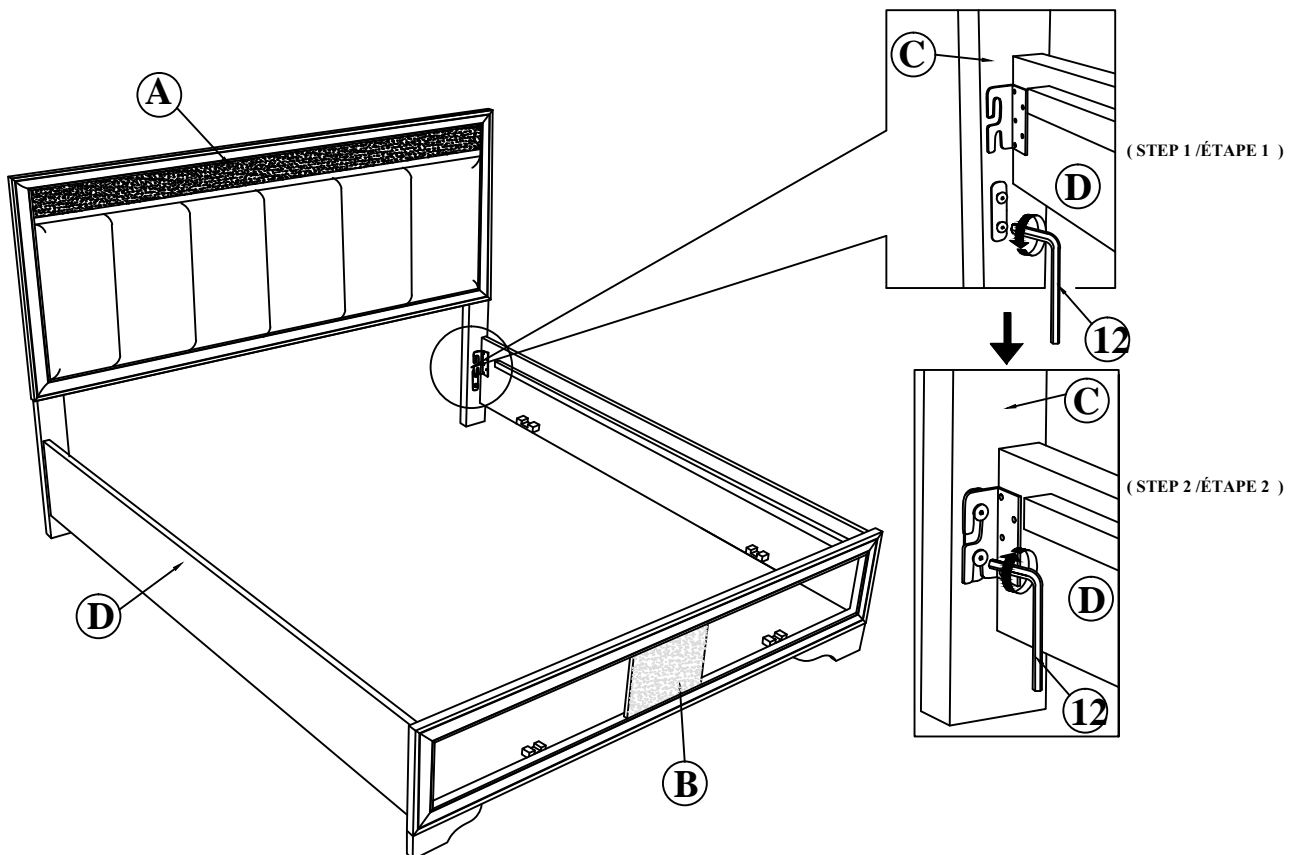

STEP 3 / ÉTAPE 3 :

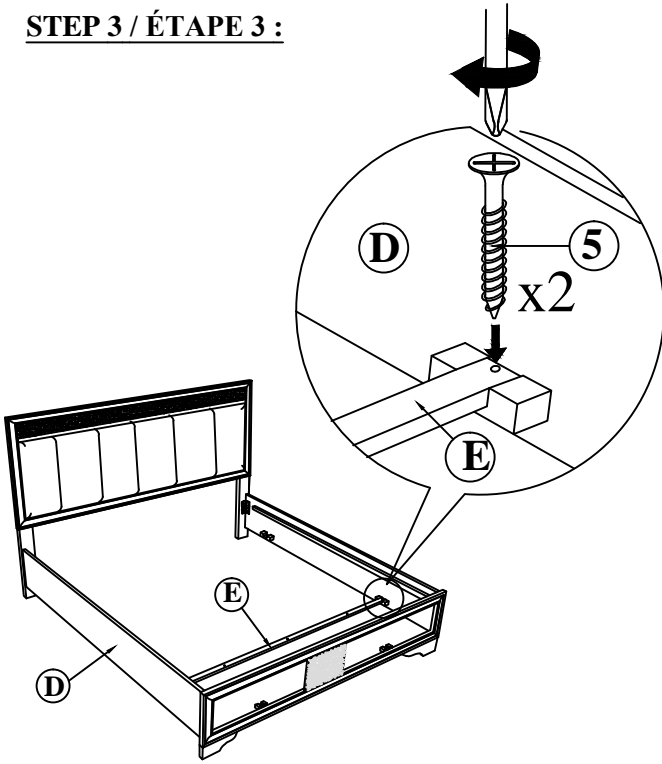

STEP 4 / ÉTAPE 4 :

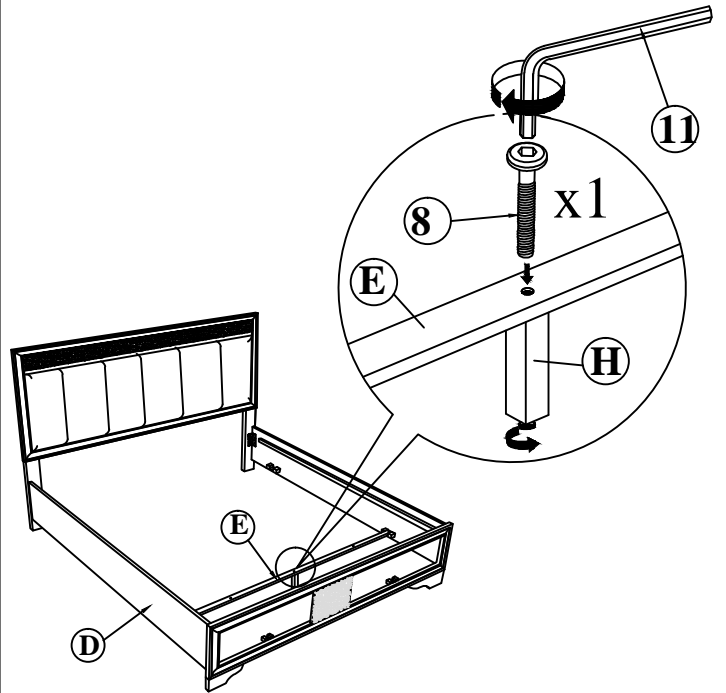

STEP 5 / ÉTAPE 5 :

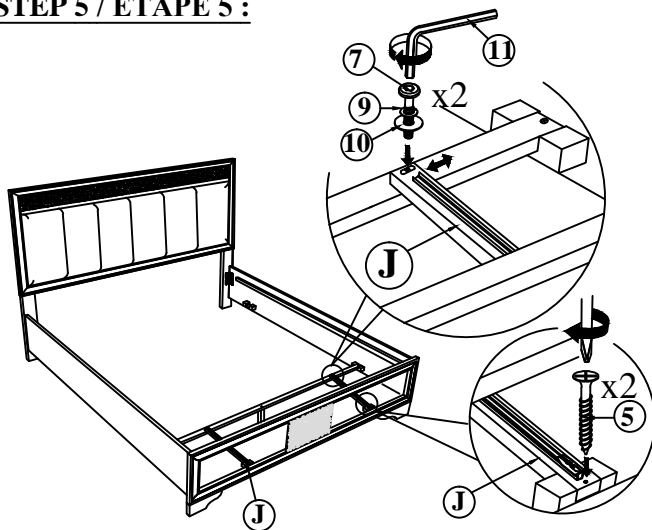

STEP 6 / ÉTAPE 6 :

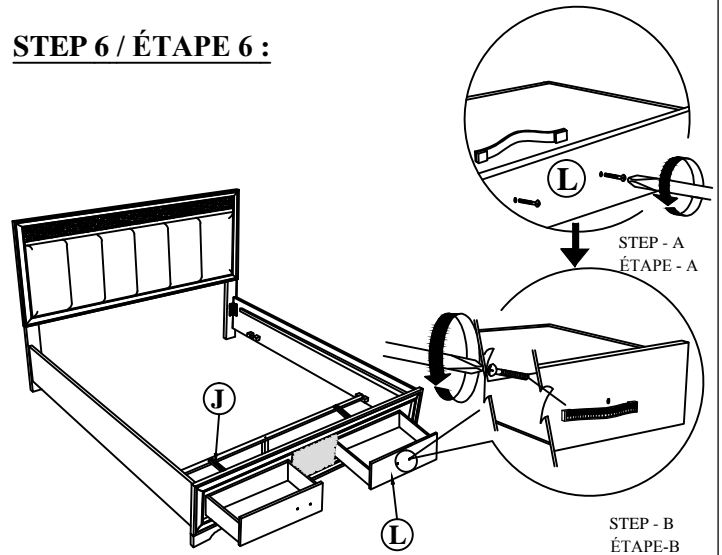

STEP 7 / ÉTAPE 7 :

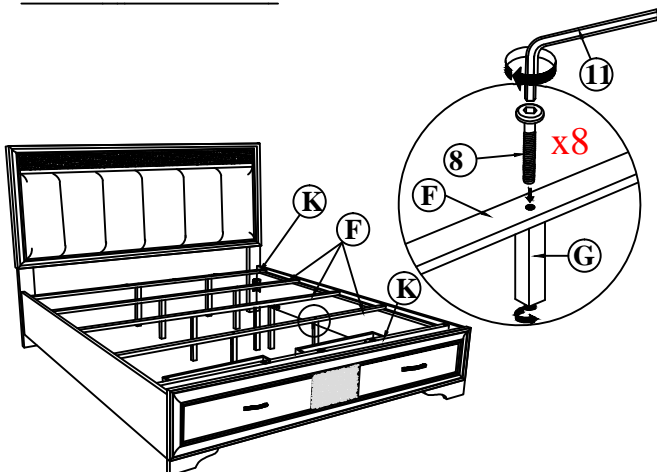

STEP 8 / ÉTAPE 8 :

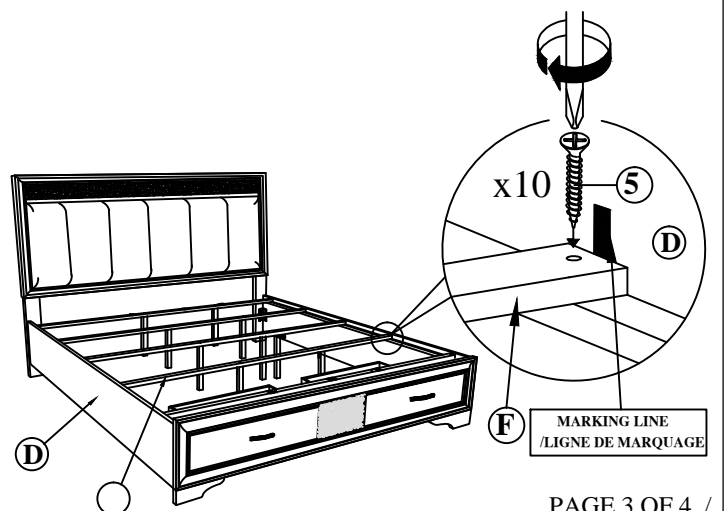

MARKING LINE / LIGNE DE MARQUAGE

STEP 9 / ÉTAPE 9 :

MARKING LINE /
LIGNE DE MARQUAGE

F

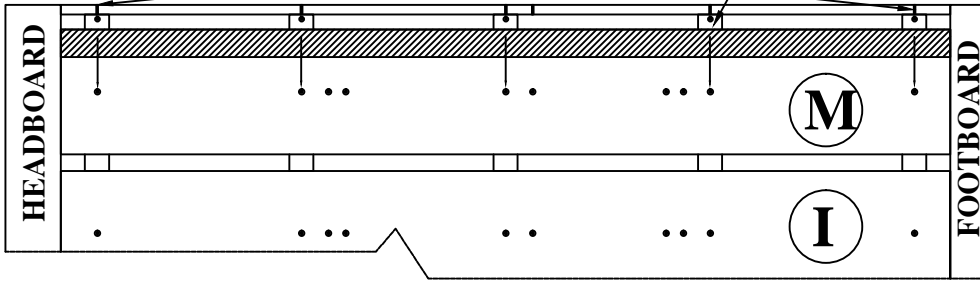

TIGHTEN THE PANHEAD SCREW (6)
BY FOLLOW THE ARROW AS SHOWN

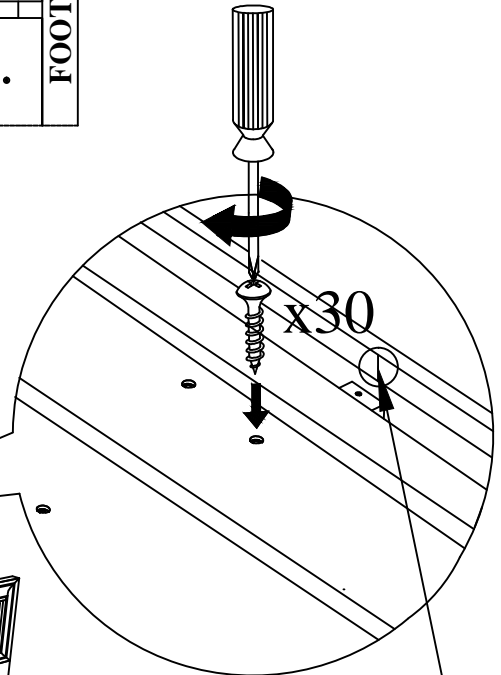
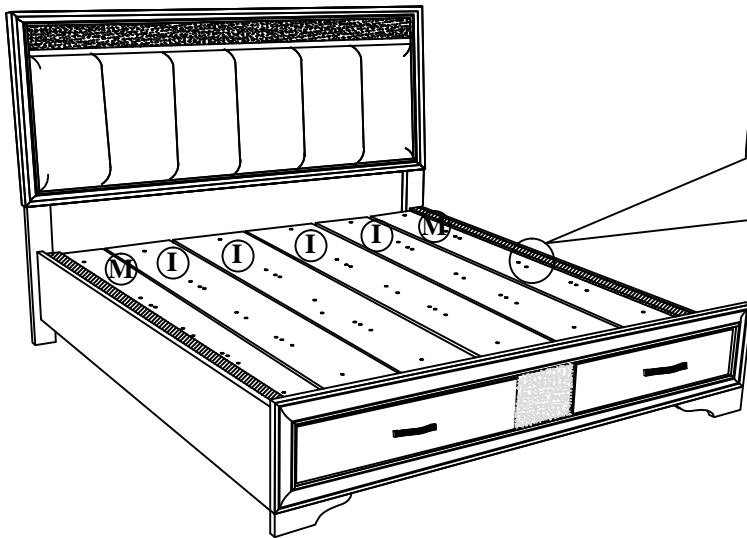

MARKING LINE
/LIGNE DE MARQUAGE

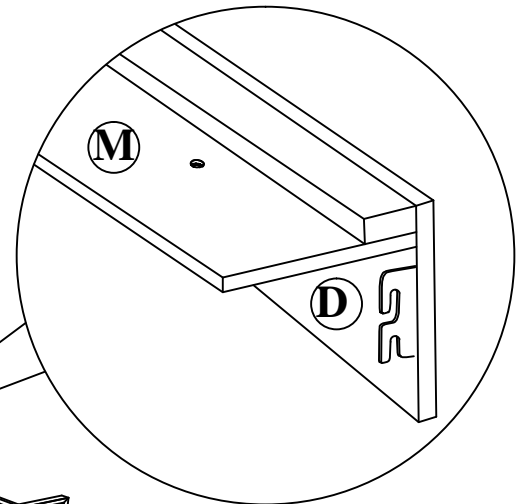
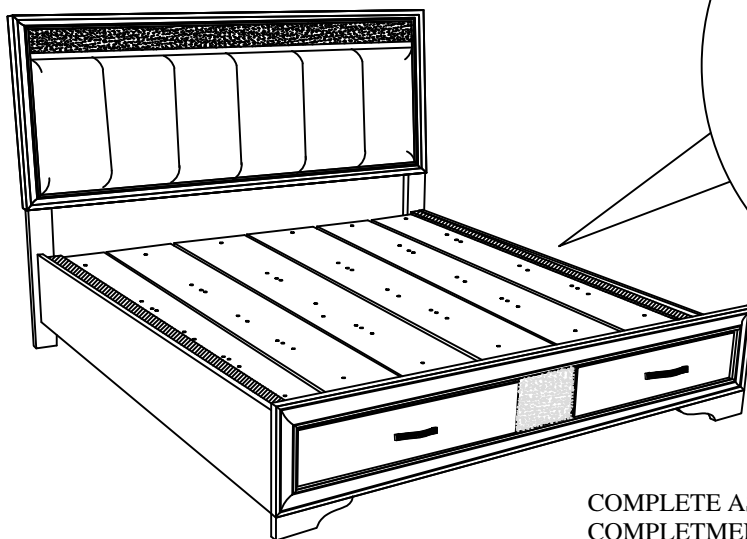

COMPLETE ASSEMBLY/
COMPLETMENT TERMINE