

NOTICE BEFORE ASSEMBLY

Please choose the CHAISE to be on
the LEFT or RIGHT hand side

Assembly Instruction I :CHAISE ON THE LEFT

ITEM NO.: F7139,F7140,F6988,F6989

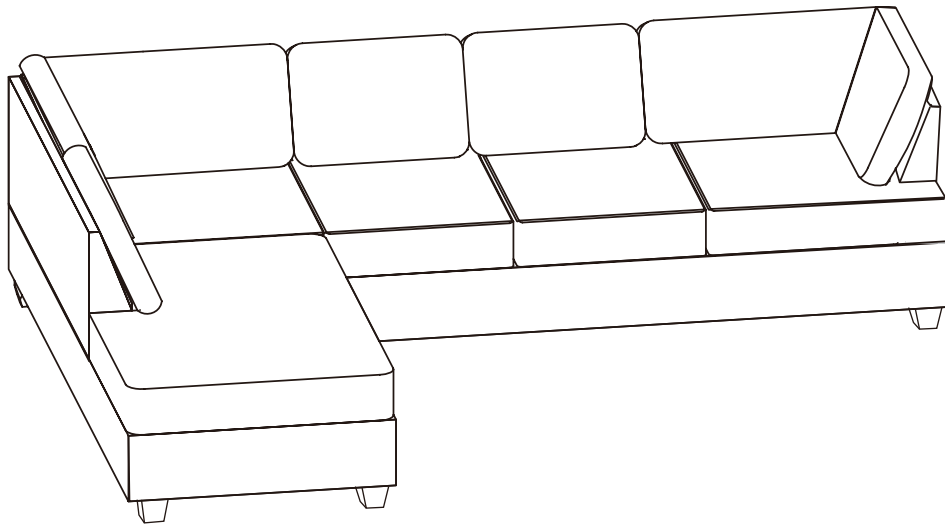

PARTS LIST

BOX-1

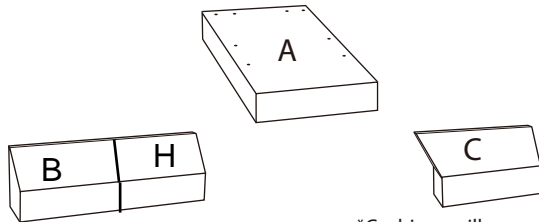





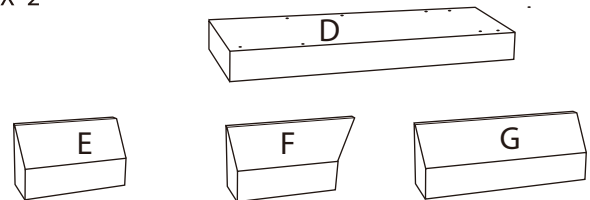

*Cushions, pillows and legs included

BOX-2

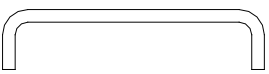

*Cushions, pillows and legs included

- | | | | | |
|---|--|--|--|---|
| 1.  x13 | 2.  x13 | 3.  x13 | 4.  x13 | 5.  x2 |
| 6.  x8 | 7.  x2 | | | |

BEFORE ASSEMBLY

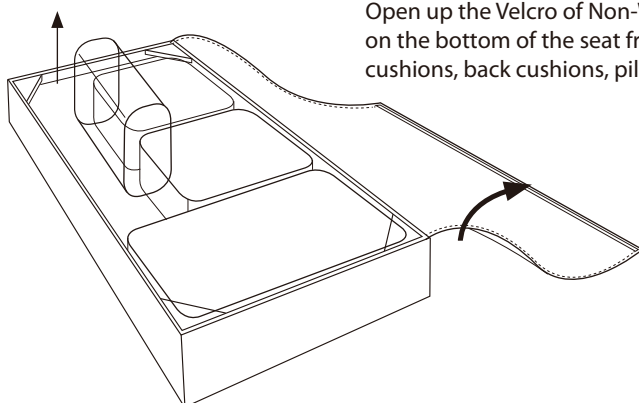

Open up the Velcro of Non-Woven Fabric cover on the bottom of the seat frame to remove seat cushions, back cushions, pillows and hardware.

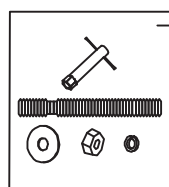

*****PLEASE REMOVE ALL PARTS FROM SEAT FRAMES BEFORE ASSEMBLY*****

CHAISE ON THE LEFT

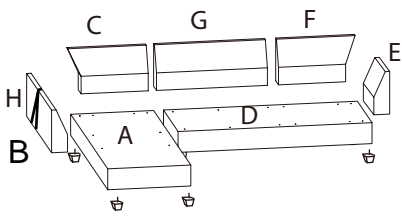

CHAISE - BOX 1

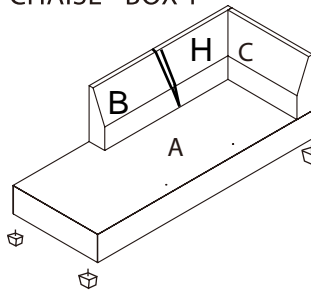

SOFA - BOX 2

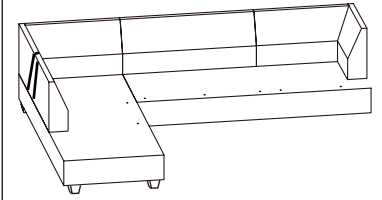
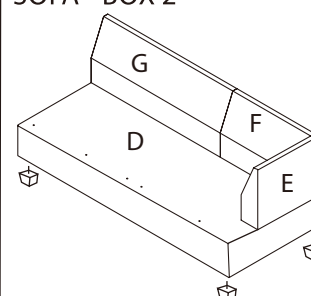

CHAISE ASSEMBLY INSTRUCTION-BOX 1

STEP 1 - INSERT THREADED ROD INTO SEAT BACKS

*Stop when the rod starts coming out on the other end

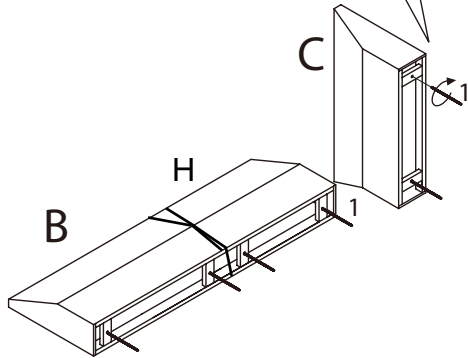
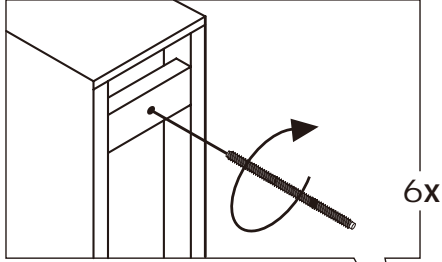

STEP 2 - MOUNTED SEAT BACKS INTO THE SEAT FRAME

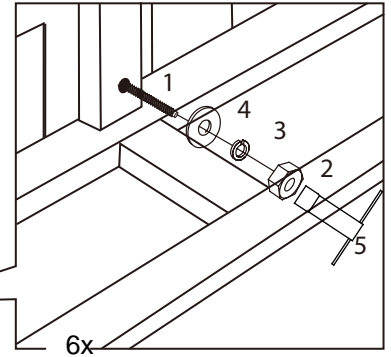
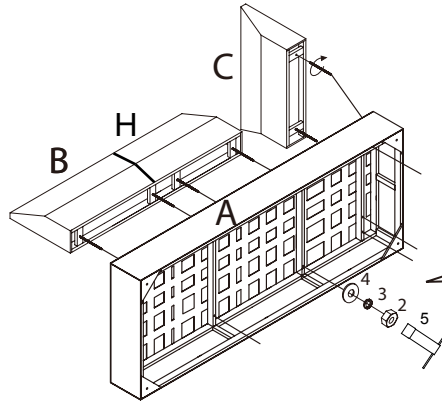

STEP 3 - PUT BACK THE FABRIC COVER AND INSERT LEGS

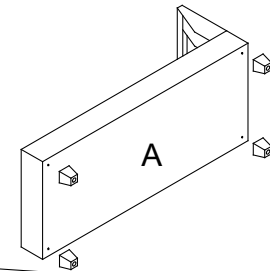
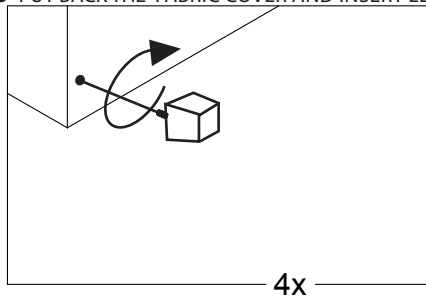

SOFA ASSEMBLY INSTRUCTION-BOX 2

STEP 1 - INSERT THREADED ROD INTO SEAT BACKS

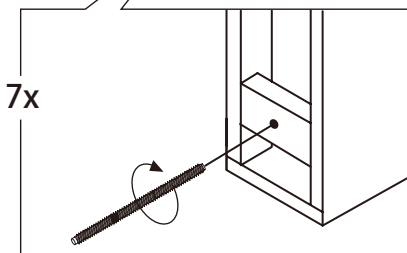
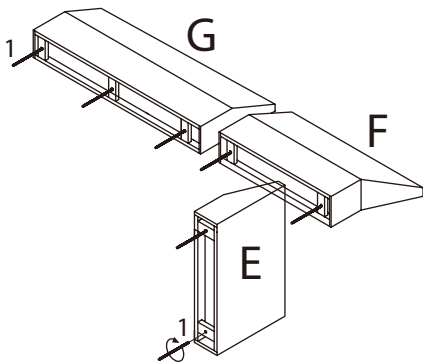

*Stop when the rod starts coming out on the other end

STEP 2 - MOUNT SEAT BACKS INTO THE SEAT FRAME

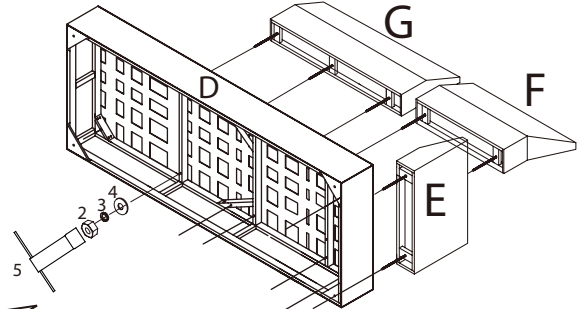
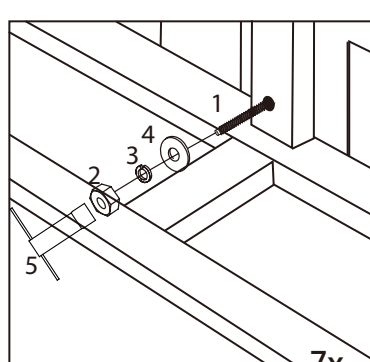

STEP 3 - PUT BACK THE FABRIC COVER AND INSERT LEGS

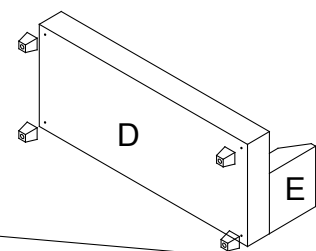
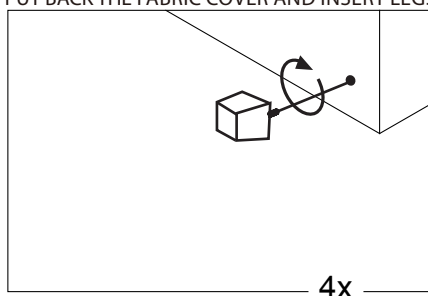

NOTICE BEFORE ASSEMBLY

Please choose the CHAISE to be on
the LEFT or RIGHT hand side

Assembly Instruction II:CHAISE ON THE RIGHT

ITEM NO.: F7139,F7140,F6988,F6989

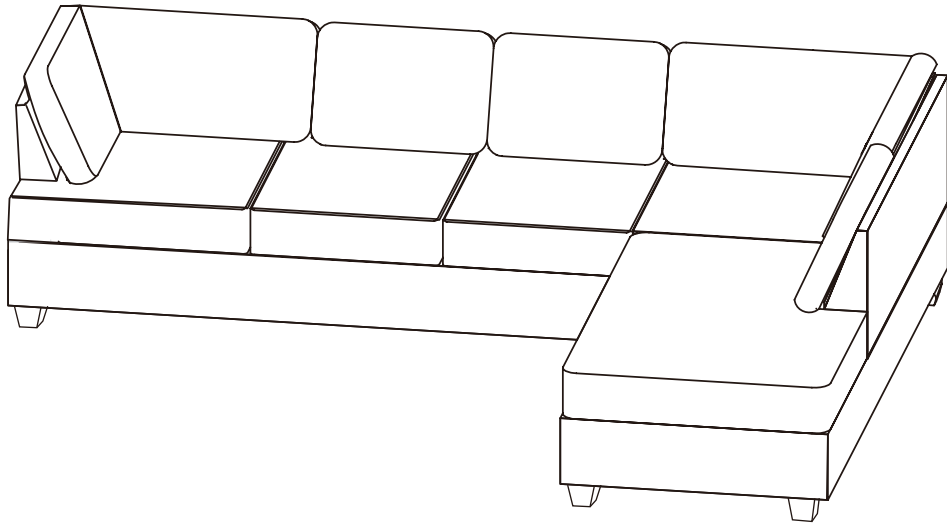

PARTS LIST

BOX-1

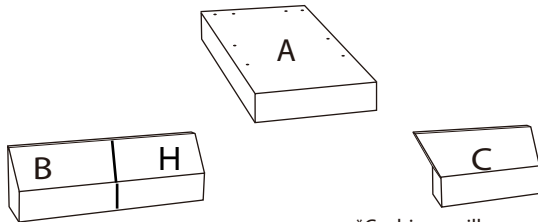

*Cushions, pillows and legs included

BOX-2

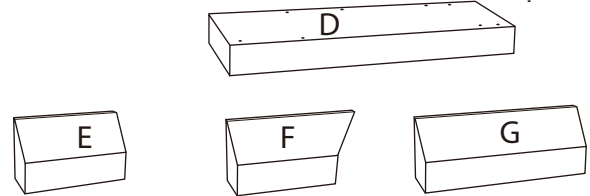

*Cushions, pillows and legs included

1.  x13

2.  x13

3.  x13

4.  x13

5.  x2

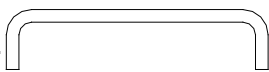
6.  x2

7.  x8

BEFORE ASSEMBLY

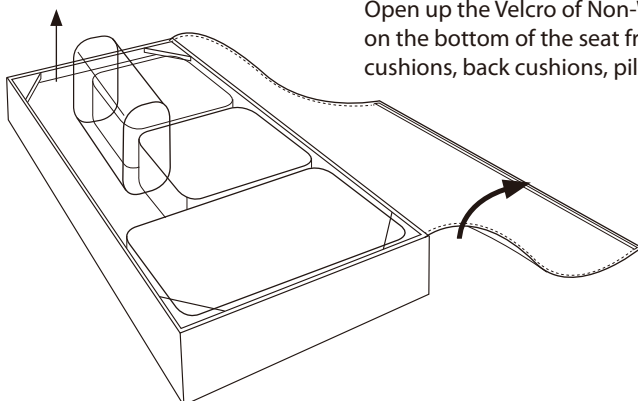

Open up the Velcro of Non-Woven Fabric cover on the bottom of the seat frame to remove seat cushions, back cushions, pillows and hardware.

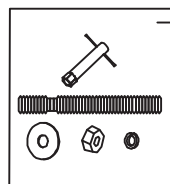

*****PLEASE REMOVE ALL PARTS FROM SEAT FRAMES BEFORE ASSEMBLY*****

CHAISE ON THE RIGHT

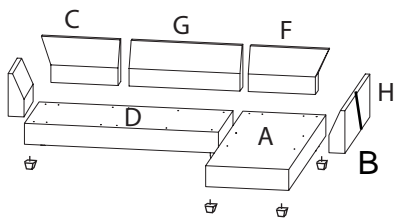

CHAISE - BOX 1

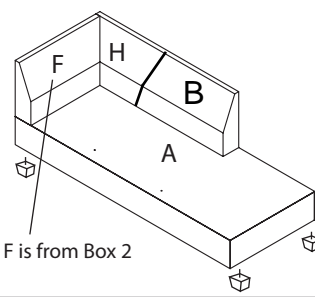

SOFA - BOX 2

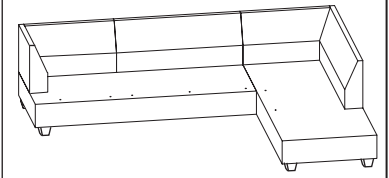
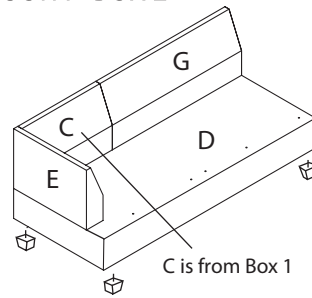

CHAISE ASSEMBLY INSTRUCTION-BOX 1

STEP 1 - INSERT THREADED ROD INTO SEAT BACKS

*Stop when the rod starts coming out on the other end

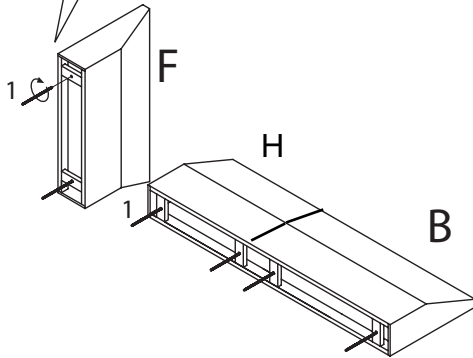
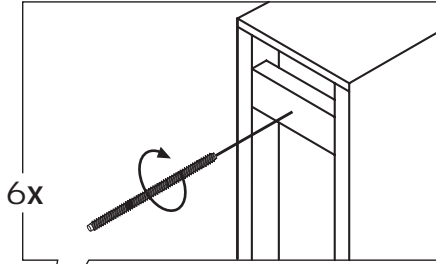

STEP 2 - MOUNT SEAT BACKS INTO THE SEAT FRAME

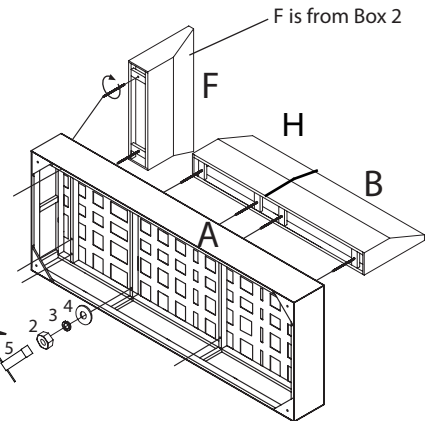
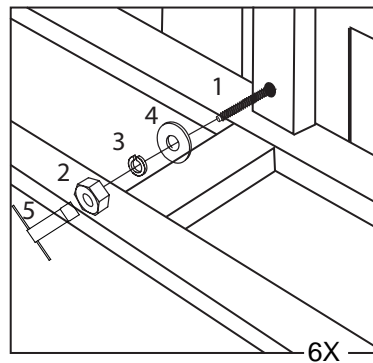

STEP 3 - PUT BACK THE FABRIC COVER AND INSERT LEGS

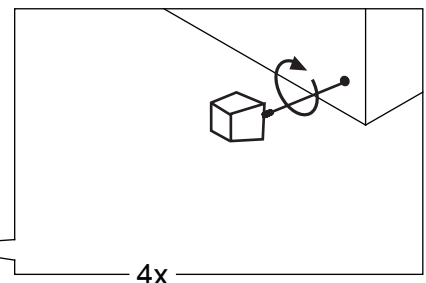
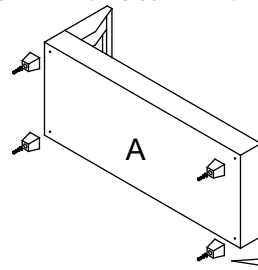

SOFA ASSEMBLY INSTRUCTION-BOX 2

STEP 1 - INSERT THREADED ROD INTO SEAT BACKS

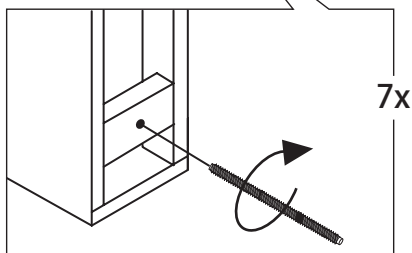
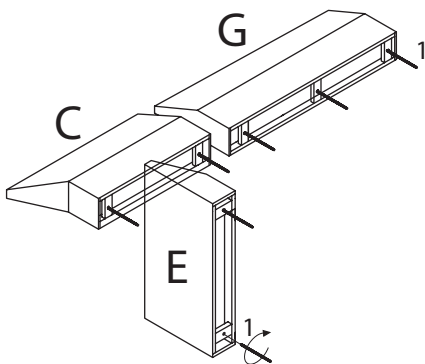

*Stop when the rod starts coming out on the other end

STEP 2 - MOUNTED SEAT BACKS INTO THE SEAT FRAME

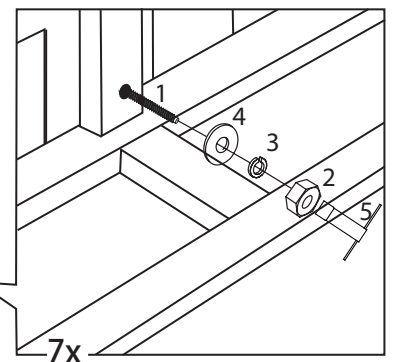
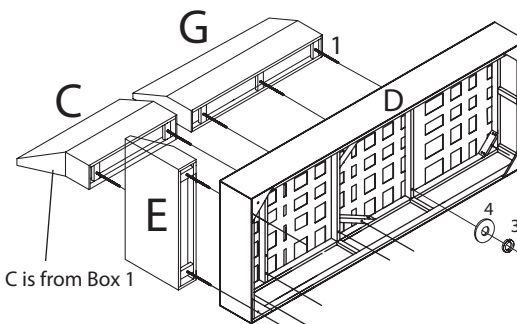

STEP 3 - PUT BACK THE FABRIC COVER AND INSERT LEGS

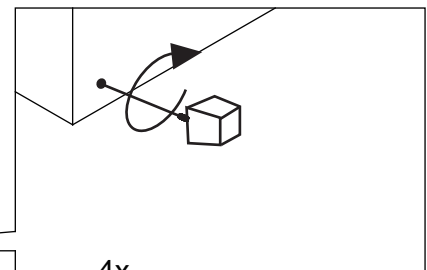
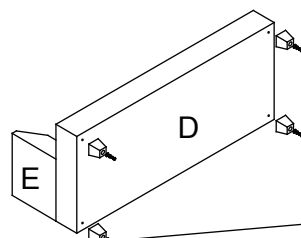

INSERT THE “n” SHAPE HANGER INTO THE SEAT FRAME TO ATTACH THE SECTIONAL TOGETHER.

