

Assembly Instruction

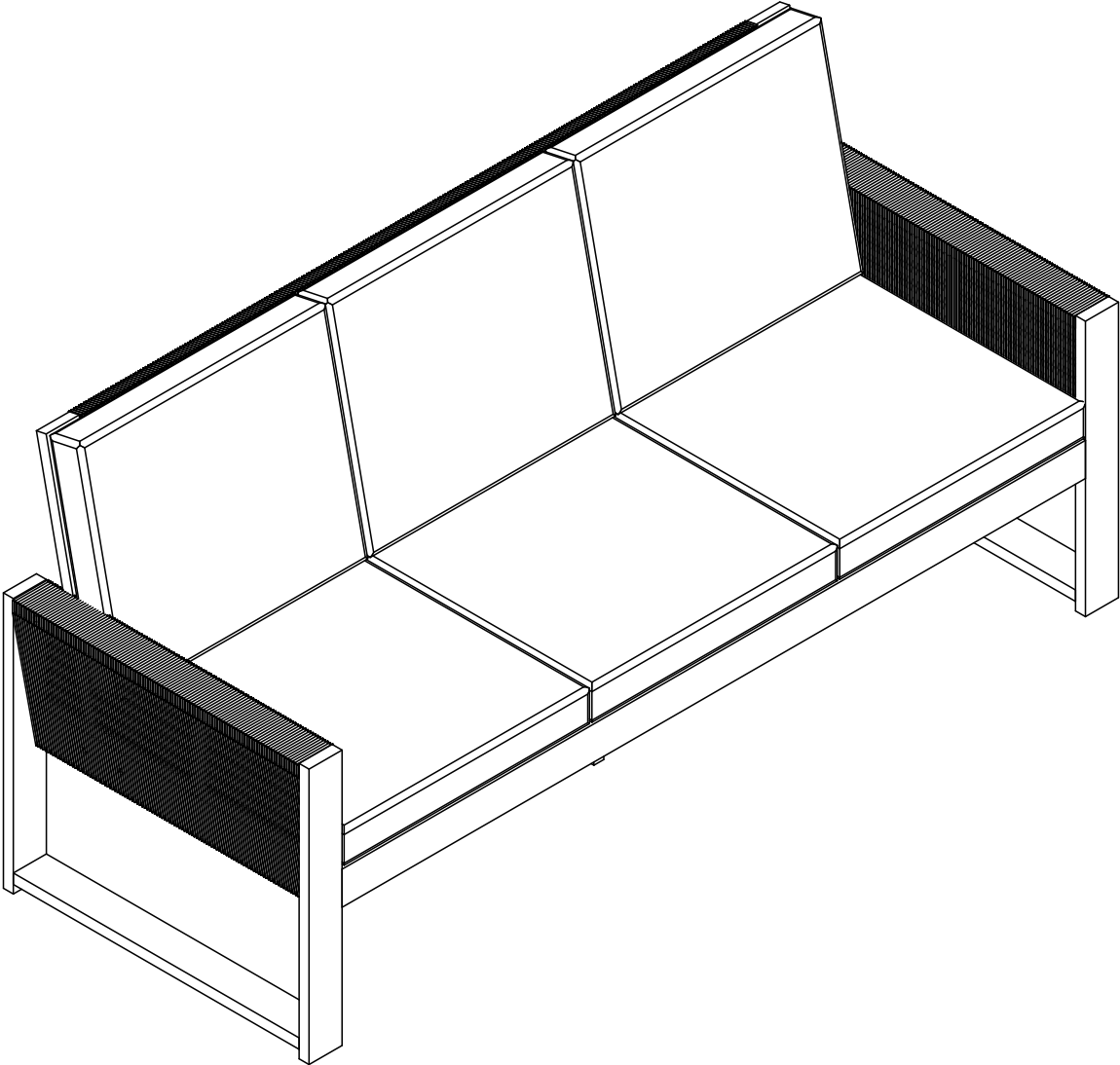

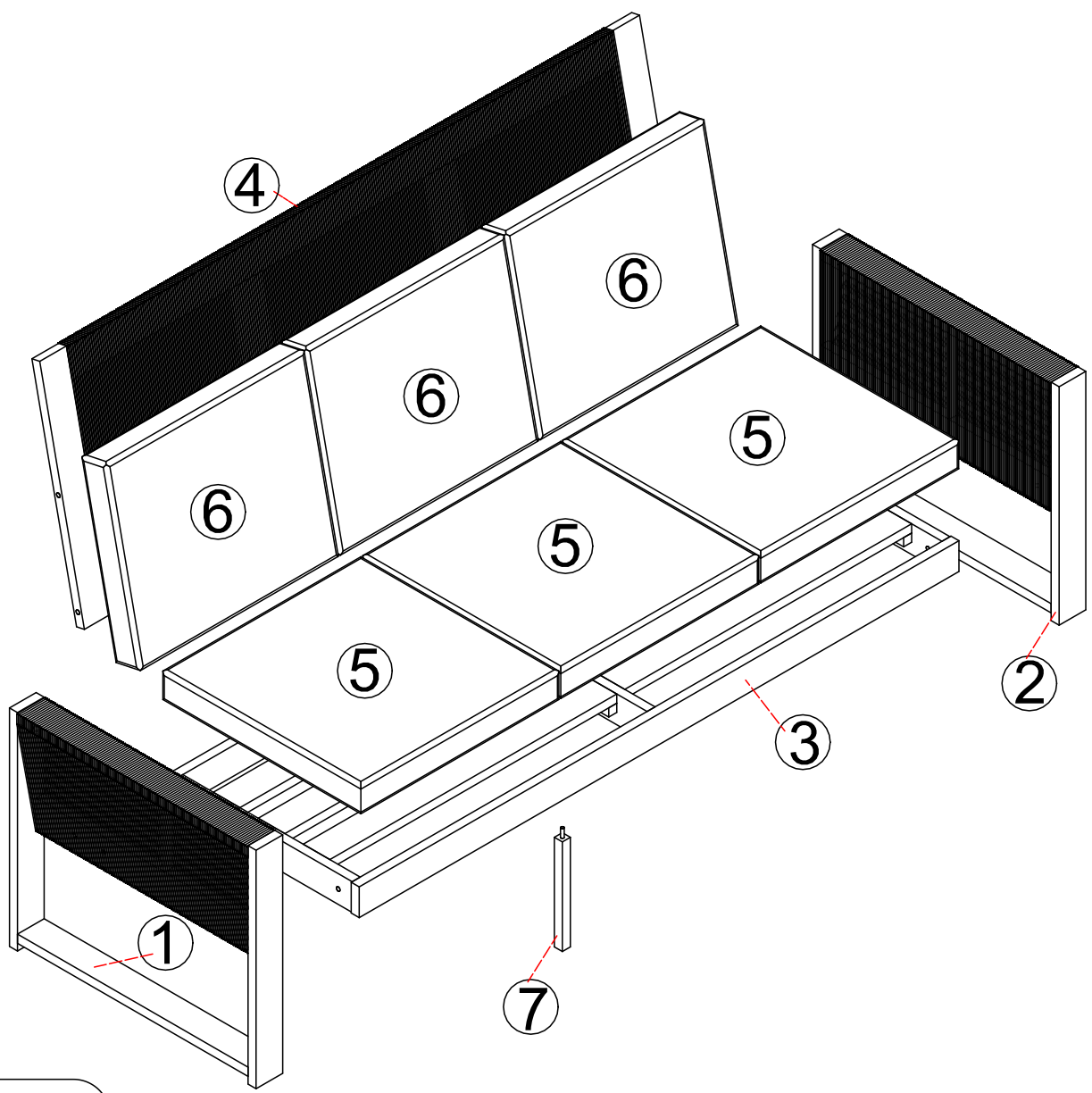

Assembly Instruction



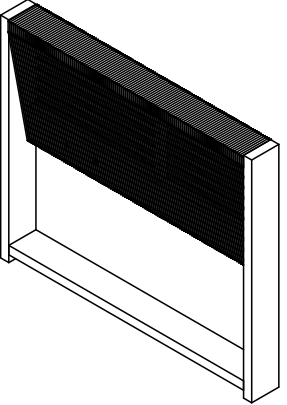
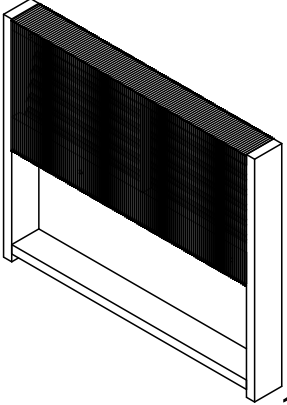
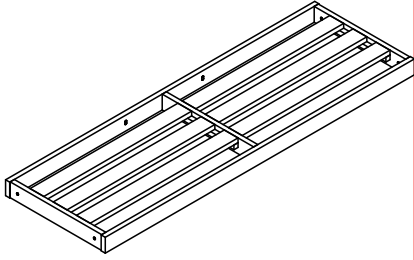
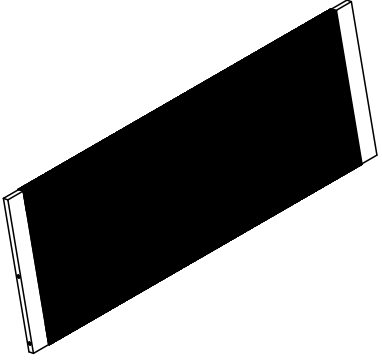
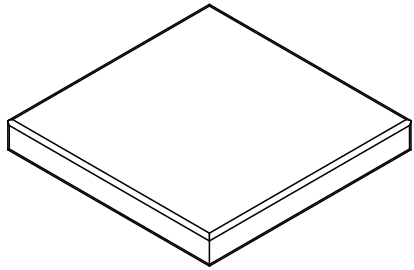
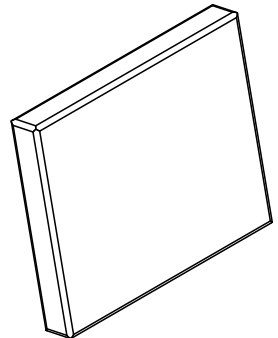

2 PERSONS

An icon consisting of two simple human figures standing side-by-side, representing the seating capacity of the bench.

PARTS LIST

| | | |
|---|---|--|
| <p>①</p>  <p>1PC</p> | <p>②</p>  <p>1PC</p> | <p>③</p>  <p>1PC</p> |
| <p>④</p>  <p>1PC</p> | <p>⑤</p>  <p>3PC</p> | <p>⑥</p>  <p>3PC</p> |
| <p>⑦</p>  <p>1PC</p> | | |

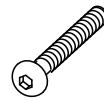
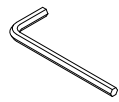
HARDWARE LIST

| | | | |
|--|--|---|--|
| <p>A</p>  <p>M8x50mm 6PCS</p> | <p>B</p>  <p>M8x60mm 2PCS</p> | <p>C</p>  <p>1PC</p> | <p>D</p>  <p>5PCS</p> |
|--|--|---|--|

STEPS

STEP-1  D x 5PCS

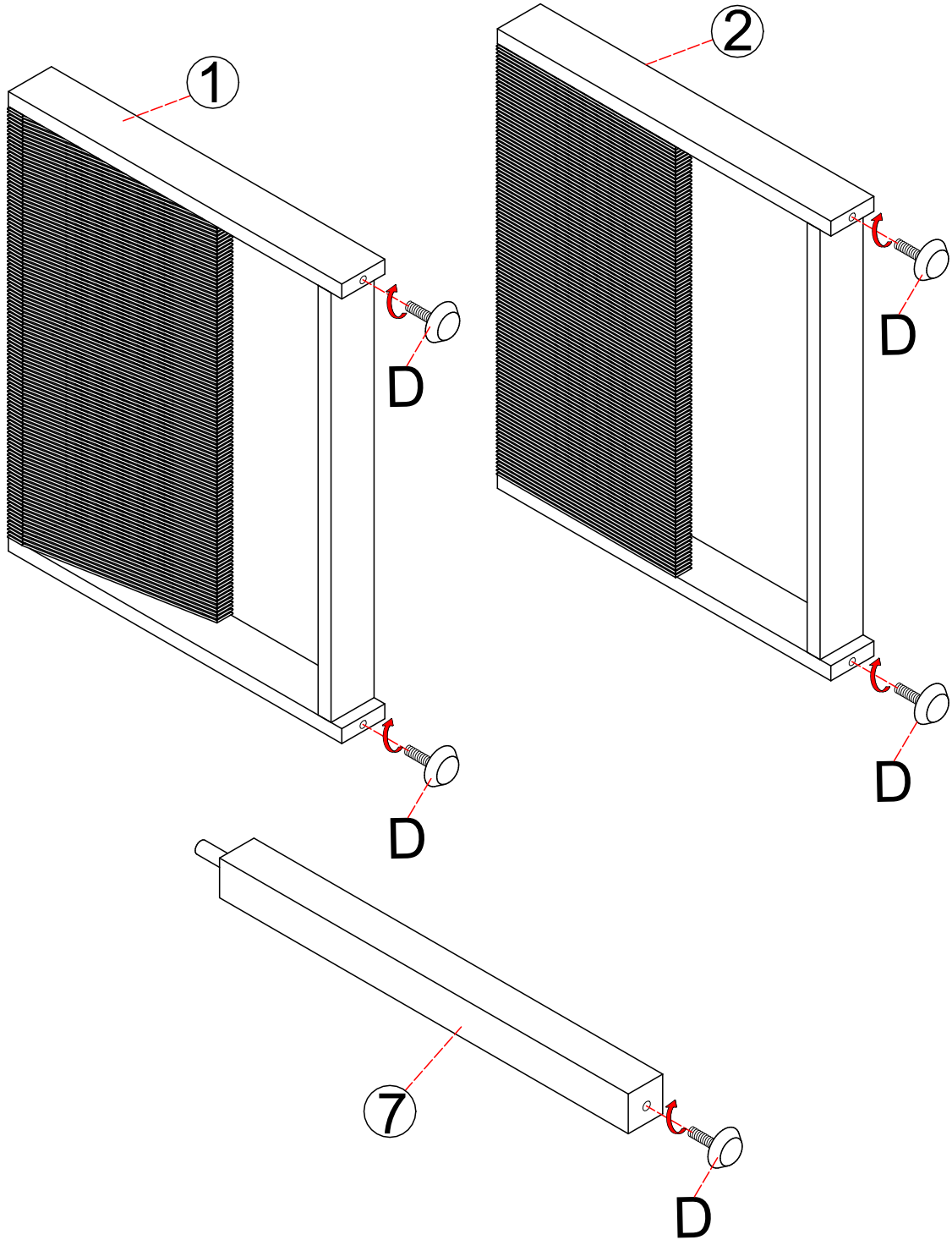

STEPS

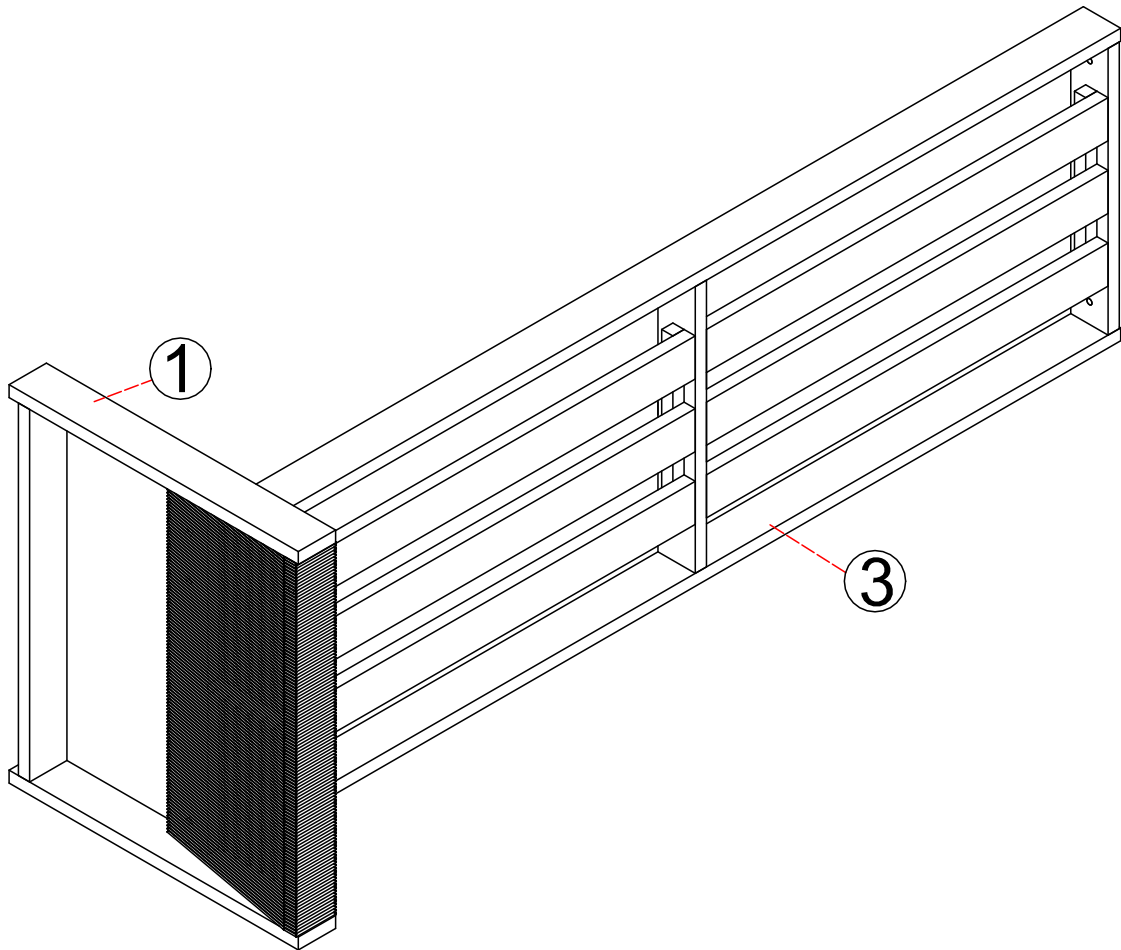
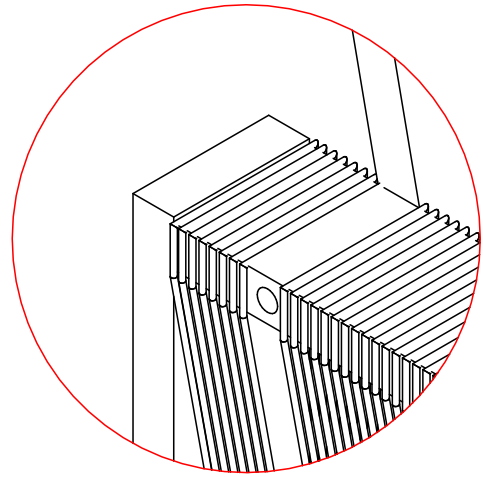

STEP-2

You need to unplug the canes and insert the screws if the canes block the assemble hole.



STEPS

STEP-3

| | |
|---|----------|
|  | A x 2PCS |
|  | C |

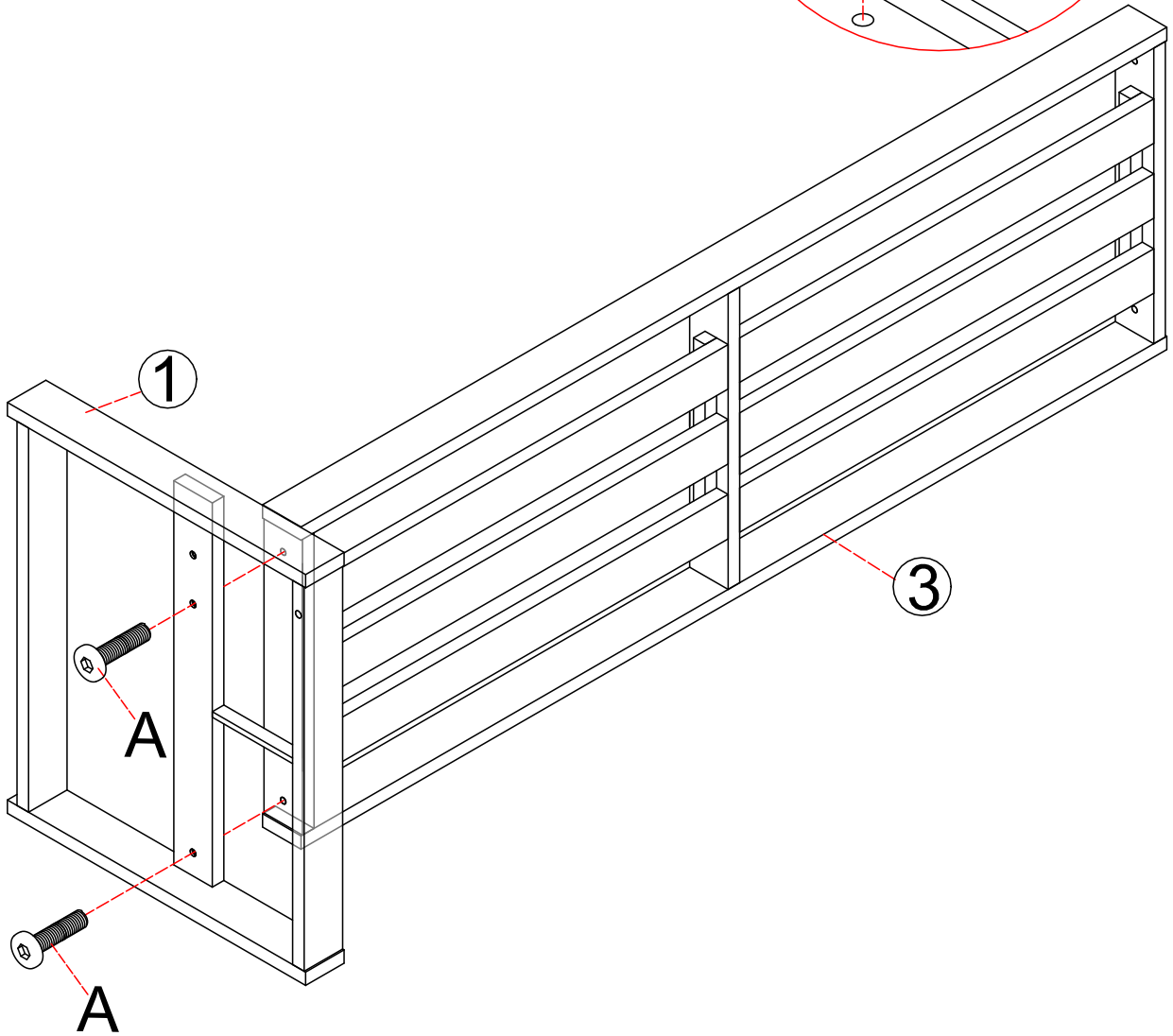
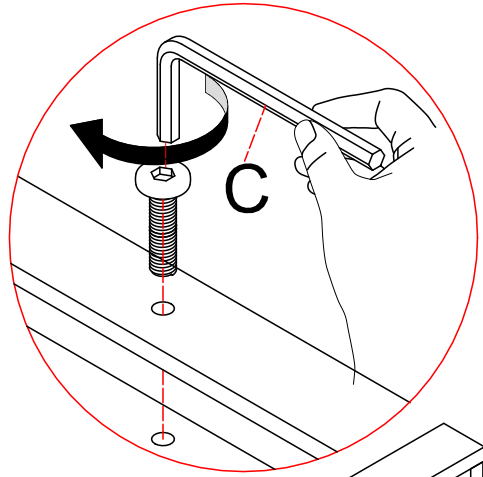

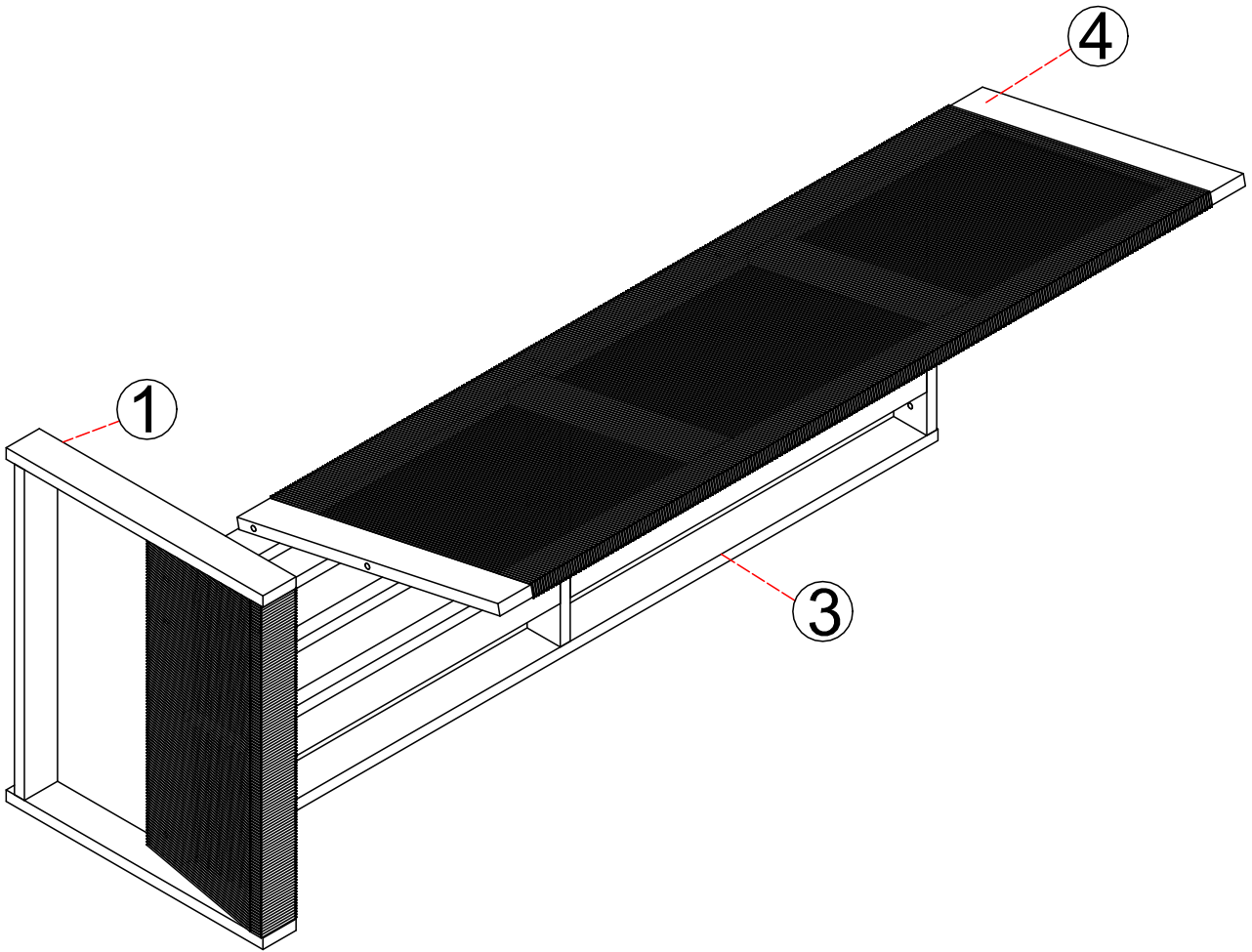

STEPS

STEP-4



STEPS

STEP-5

| | |
|---|---------|
|  | A x 1PC |
|  | B x 1PC |
|  | C |

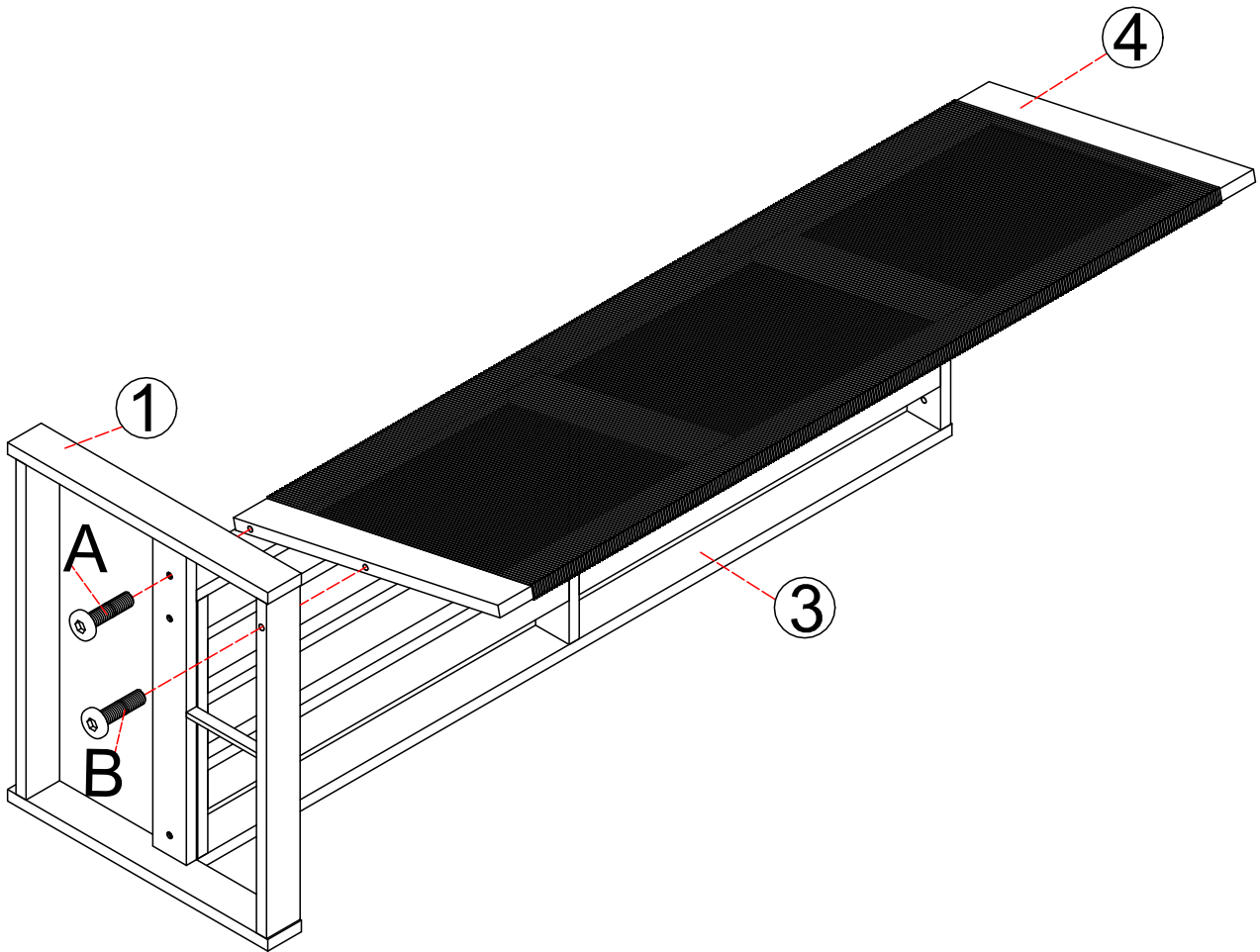
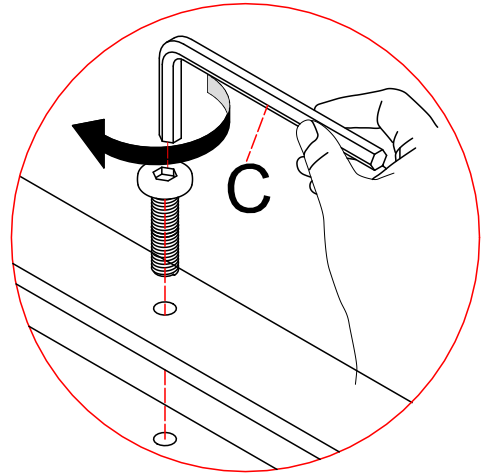

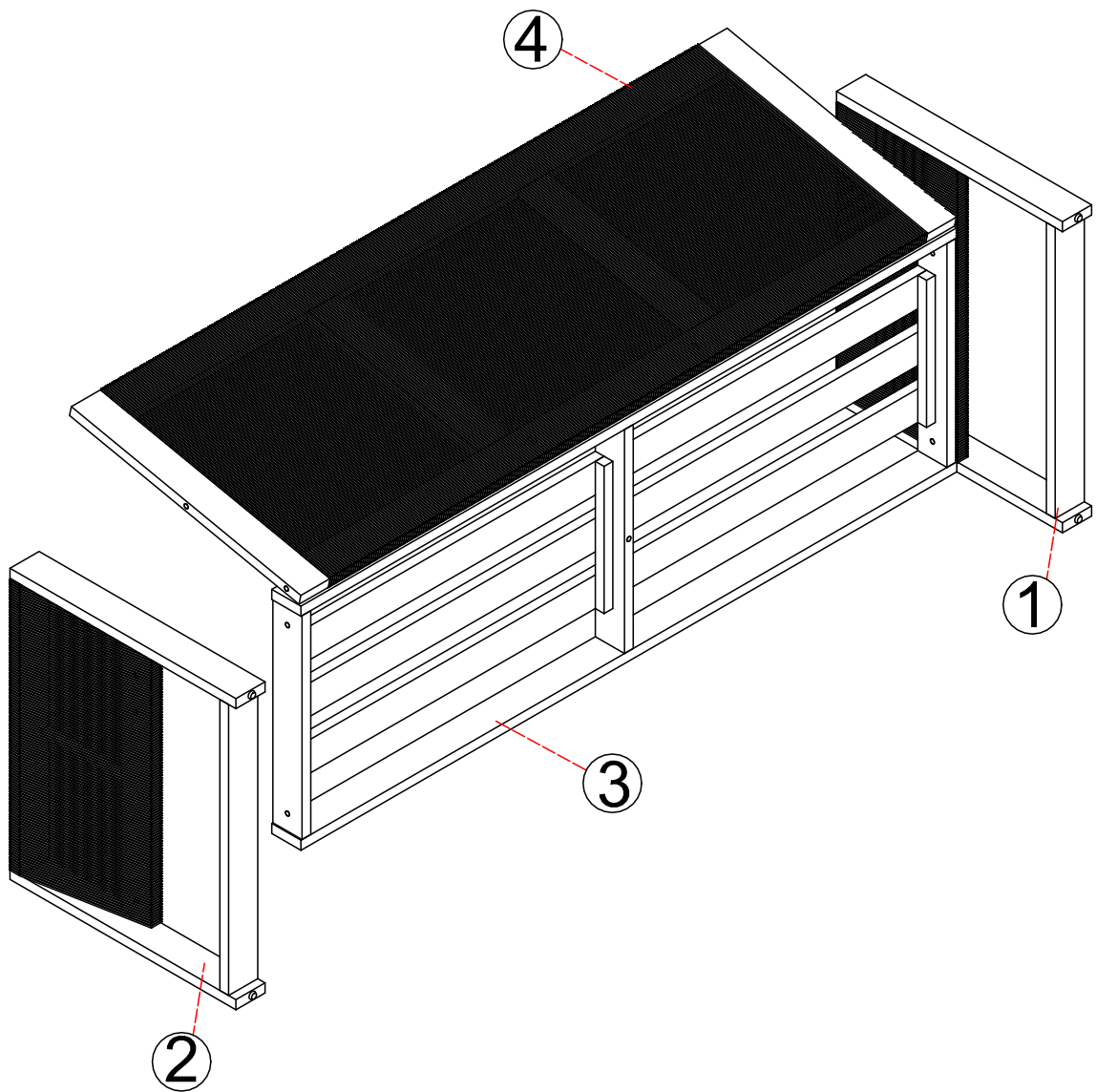

STEPS

STEP-6



STEPS

STEP-7

| | |
|---|----------|
|  | A x 3PCS |
|  | B x 1PC |
|  | C |

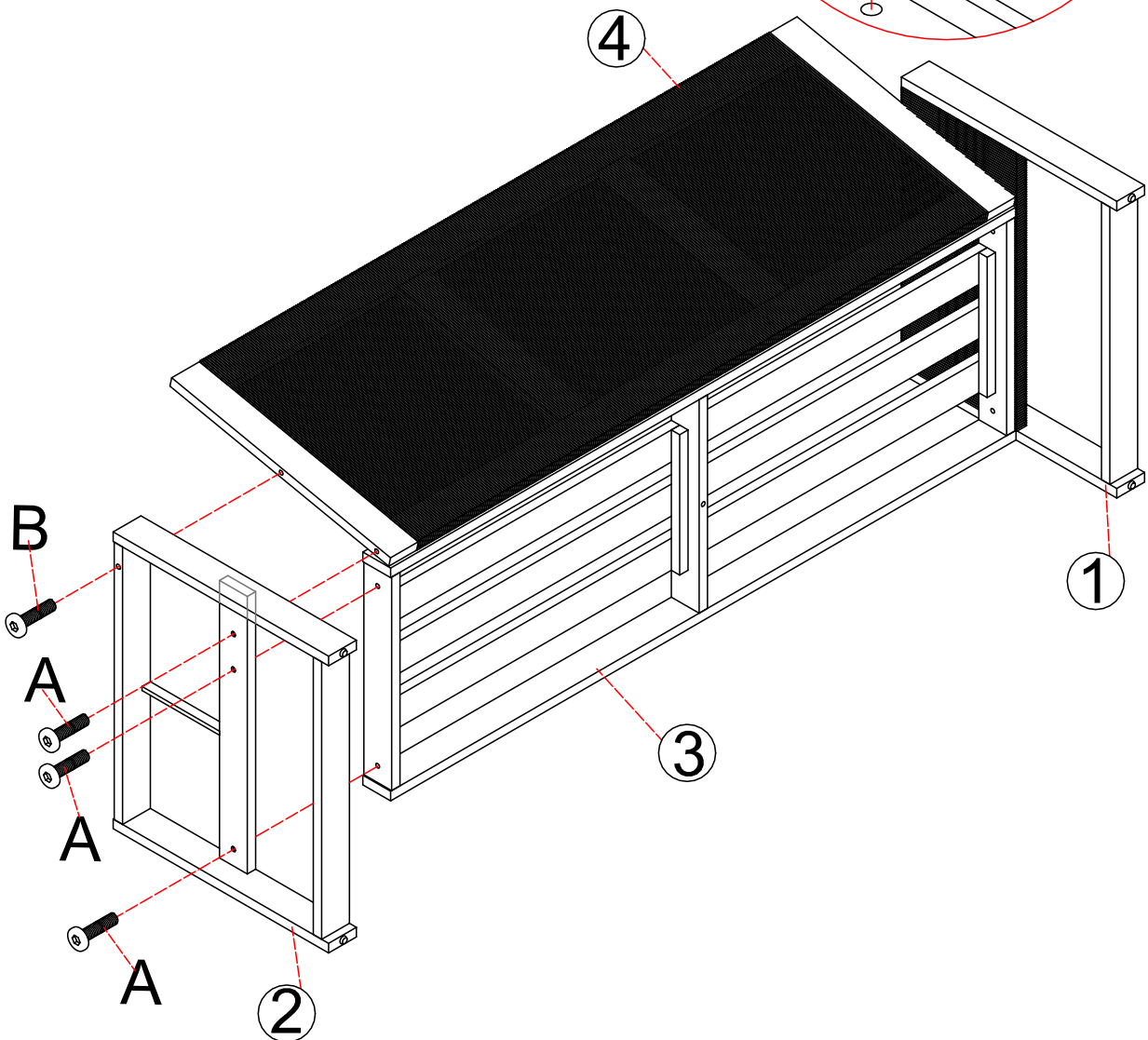
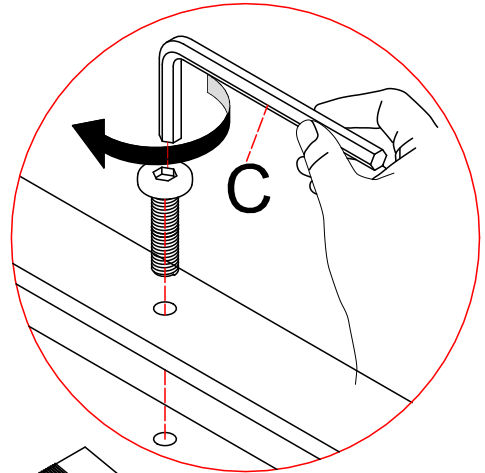

STEPS

STEP-8

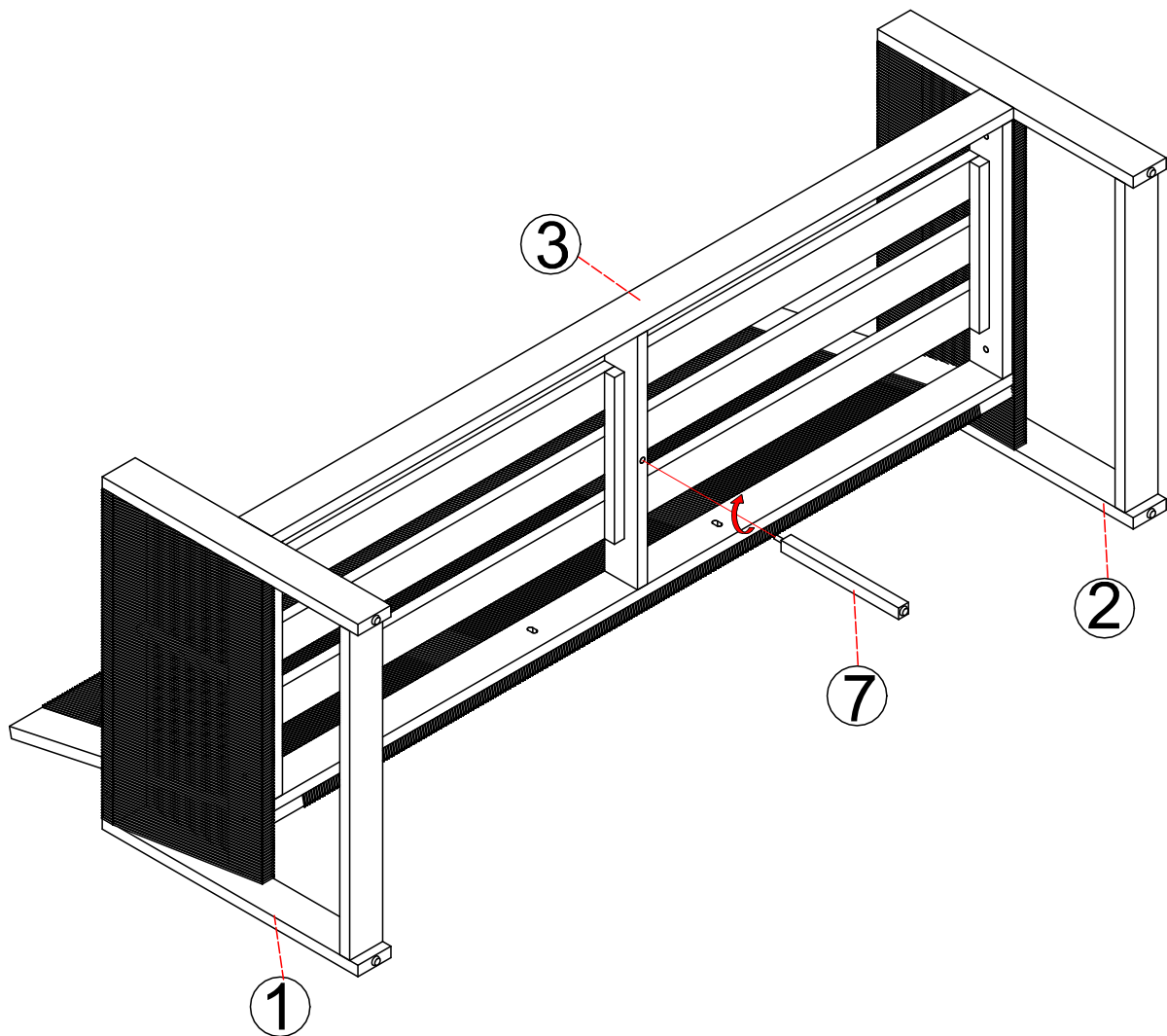

STEPS

STEP-9

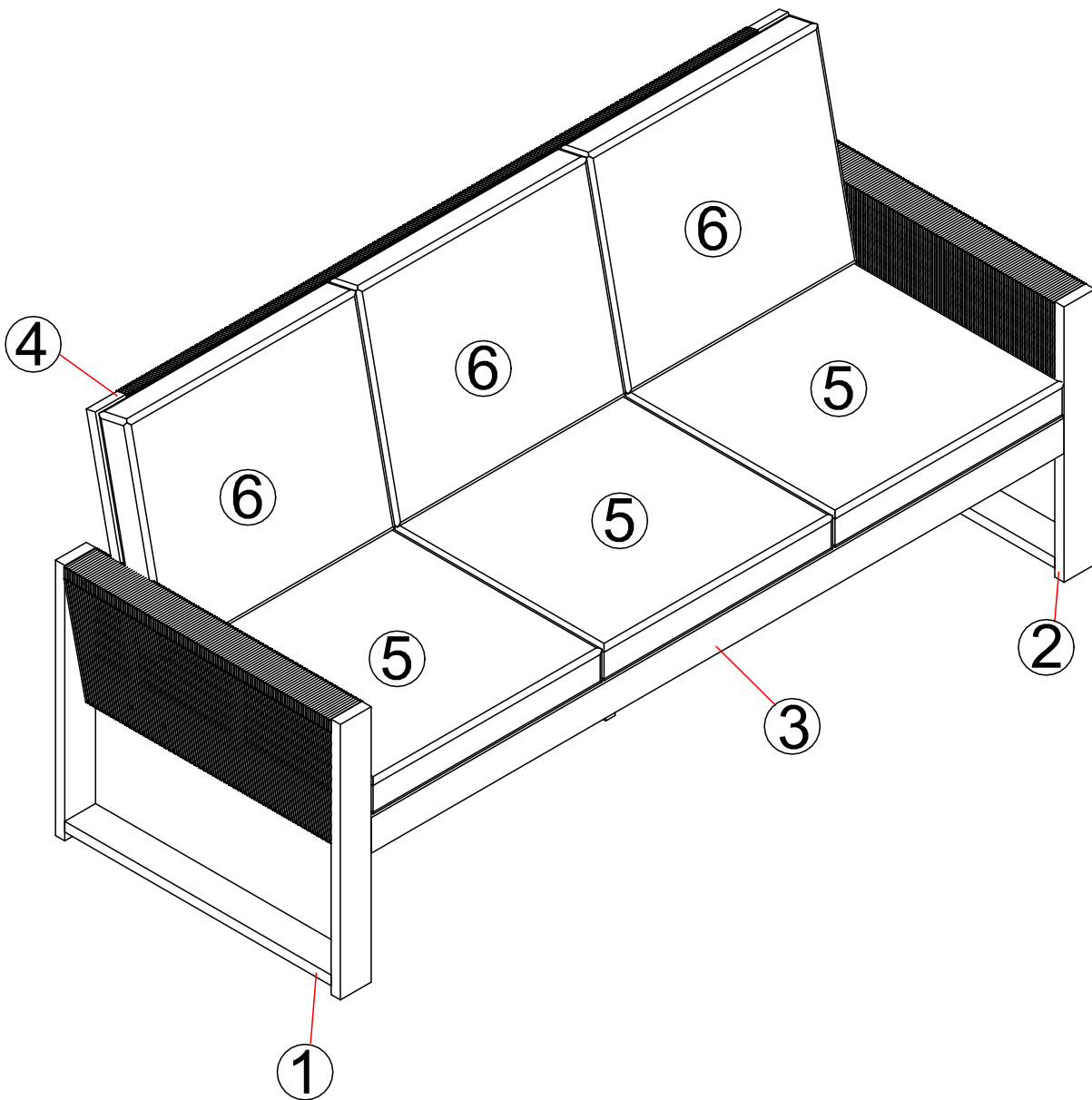

Warranty

We are committed to providing quality outdoor furniture and offer a one-year limited warranty on this product.

Terms and Conditions

This warranty covers defects in materials and workmanship under normal use and care for a period of one year from the date of purchase. Proof of purchase (dated receipt or invoice) is required for all warranty claims.

Customer Responsibilities

The customer is responsible for all freight and packing charges associated with returning the product to our service center and shipping it back after repair or replacement.

Exclusions

This warranty does not cover:

Normal wear and tear, including scratches, stains, fading, or discoloration.
Damage caused by misuse, accidents, neglect, or improper maintenance.

Damages resulting from exposure to extreme weather conditions.

Commercial use of the product.

How to File a Claim

To submit a warranty claim:

Provide proof of purchase.

Include a detailed description of the issue and photos, if applicable

Contact our customer service team for assistance. If your claim is approved, we will repair or replace the product or provide a comparable solution at our discretion.

This warranty is non-transferable and applies only to the original purchaser. For optimal product performance, we recommend following all care and maintenance instructions.