

ASSEMBLY INSTRUCTIONS

DRAWER



HOPE YOU HAVE A PERFECT SHOPPING EXPERIENCE!

Thank you for choosing our furniture! Our products are designed to be both stylish and functional, with a focus on sustainability.

We use high-quality materials to ensure that our pieces are built last, so you can enjoy them for years. Whether you're looking for a cozy or stylish furniture, we have something for everyone.

Our products are perfect for any home or office and we're confident that you'll love them as much as we do! If you have any problems with the item, please feel free to contact our customer service team by email or text.



IMPORTANT SAFETY INSTRUCTIONS



Read these instructions carefully and retain them for future use.

When using the product, basic safety precautions always be followed to reduce the risk of injury including the following:

- This product must be assembled by an adult.
- Keep children and pets away while assembling the product.
- Remove all the packing materials and review all components before assembly.
- Do not over-tighten the fasteners.
- To avoid scratching the floor, assemble the product on a soft surface, such as a carpet.
- Do not use this product if any parts are missing, damaged, or worn.
- Always use the product on a firm, level ground.
- Do not let the children climb on or play with the product.
- Do not stand on the seat.
- Do not seat on the armrest.
- Keep all sharp objects away from the upholstery.
- Regularly examine the product for wear and tear. Stop using the product at the first sign of damage or if the parts detached.

PARTS LIST

NOTICE

Please make sure all the parts are included. If there are parts missing, please feel free to contact our customer service team.

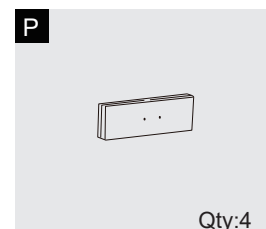
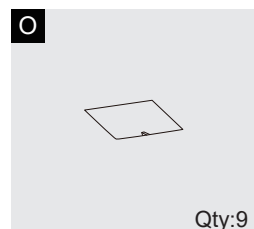
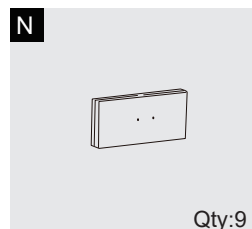
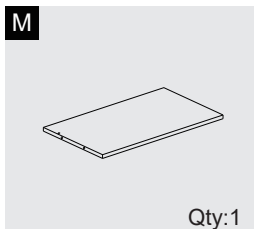
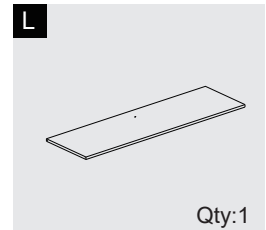
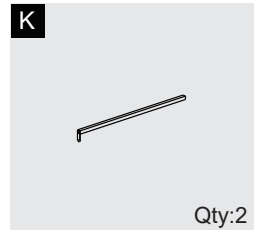
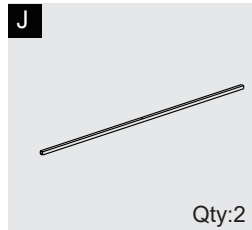
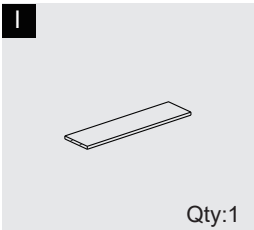
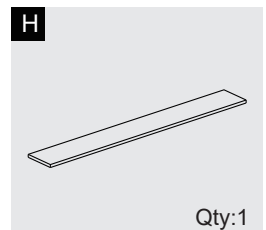
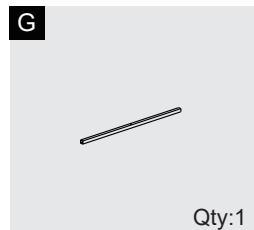
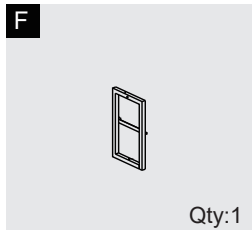
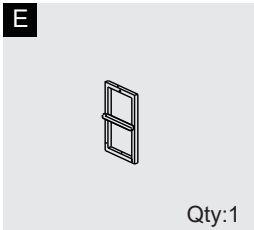
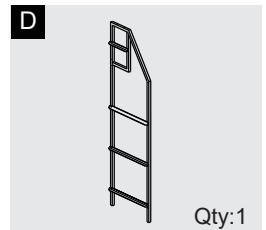
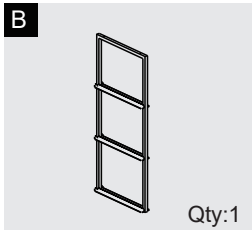
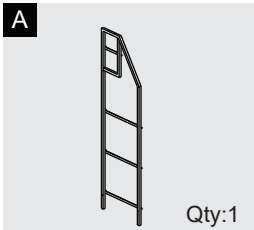

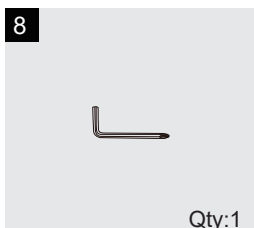
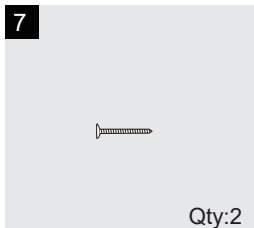
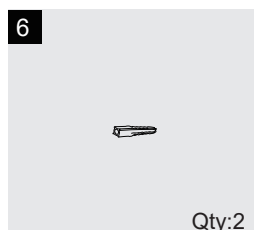
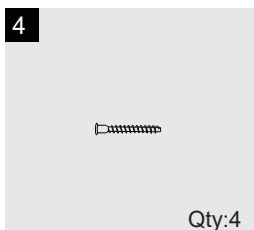
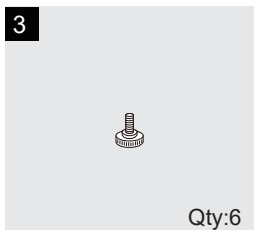
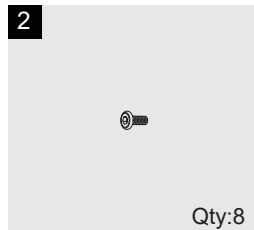
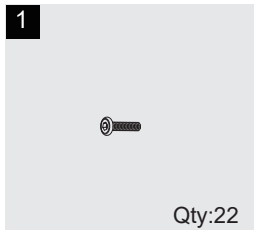
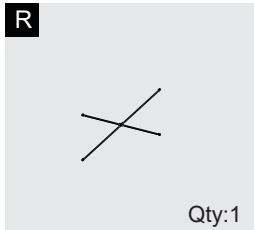
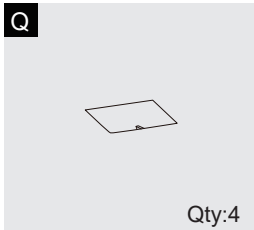

INSTALLATION STEPS

NOTICE

Lightly insert screws into their respective holes before fully tightening to ensure proper alignment.

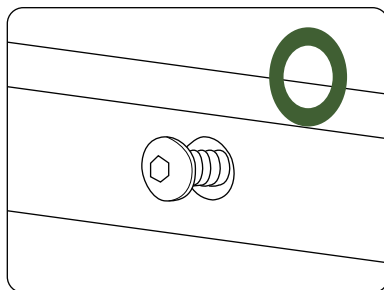
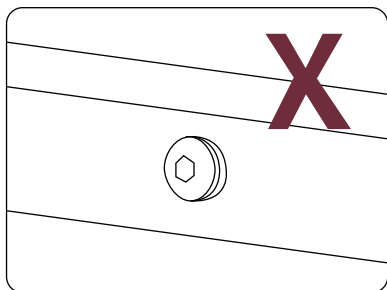

INSTALLATION STEPS

STEP 1

①*4

⑧*1

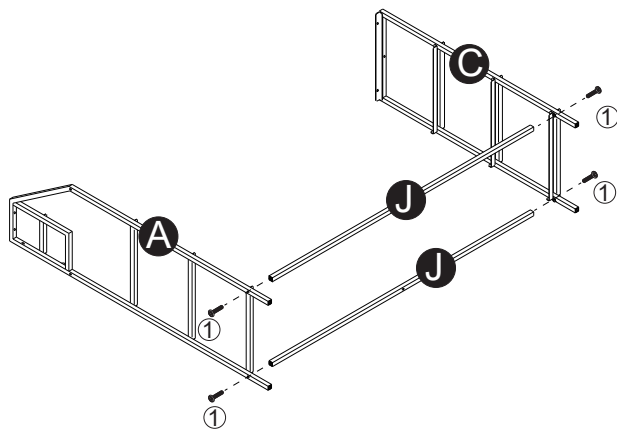

STEP 2

①*2

⑧*1

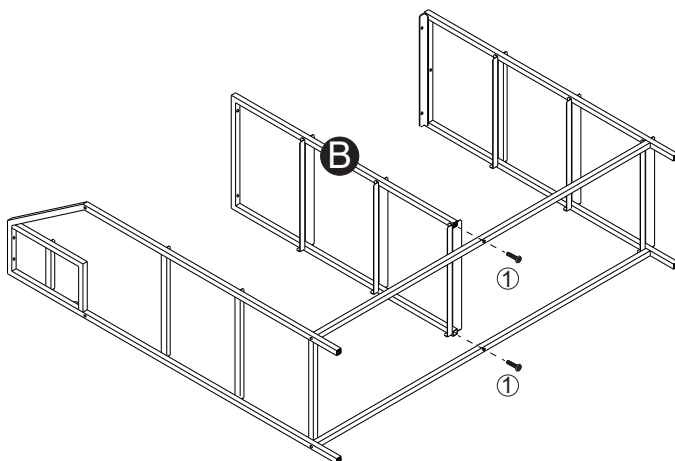

INSTALLATION STEPS

STEP 3

①*2
②*2
⑧*1

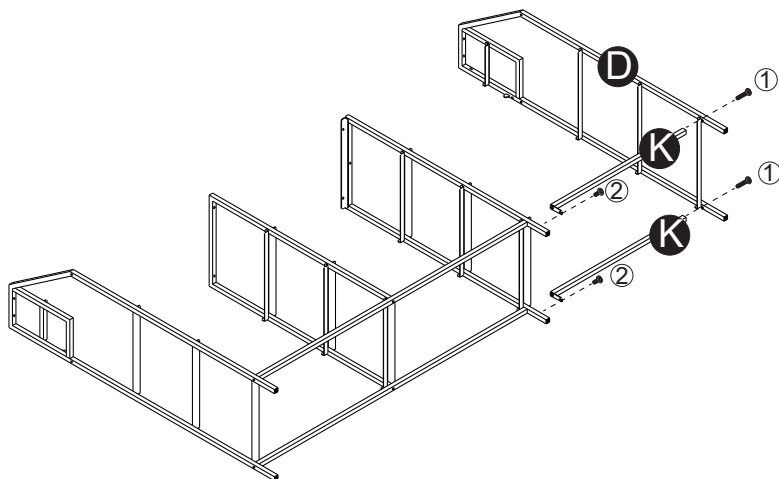

STEP 4

③*6

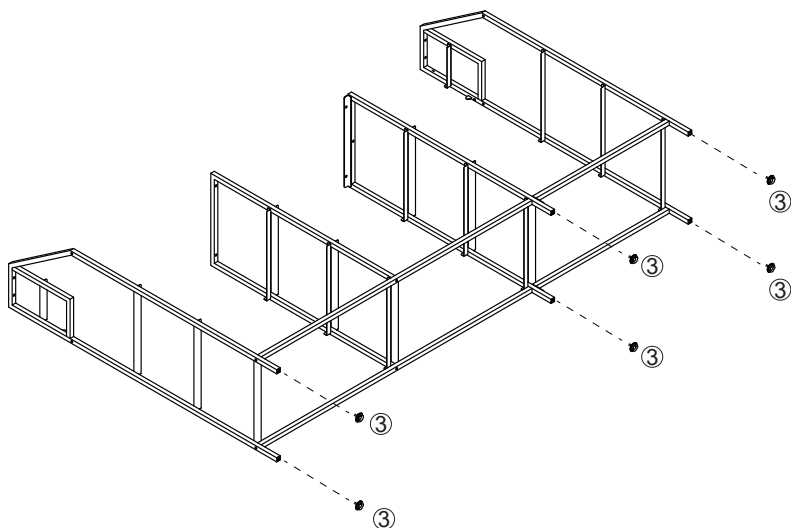

INSTALLATION STEPS

STEP 5

- ①*3
- ②*2
- ④*4
- ⑧*1
- ⑨*2

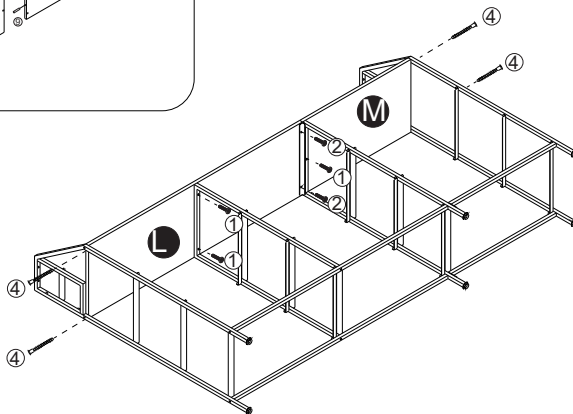
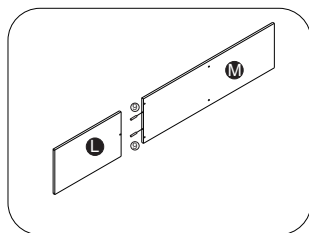

STEP 6

- ①*2
- ⑧*1

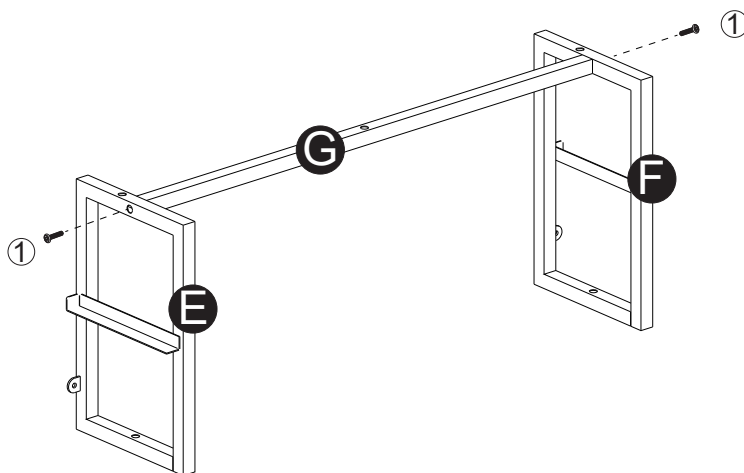

INSTALLATION STEPS

STEP 7

- ①*2
- ⑧*1

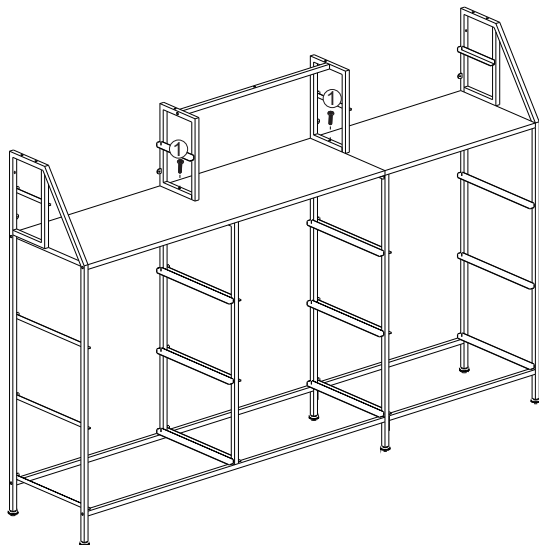

STEP 8

- ①*7
- ②*4
- ⑧*1
- ⑨*2

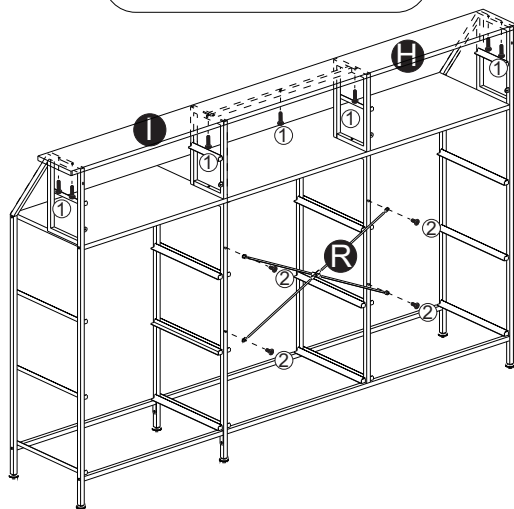
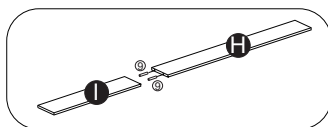

INSTALLATION STEPS

STEP 7

⑤*13

⑧*1

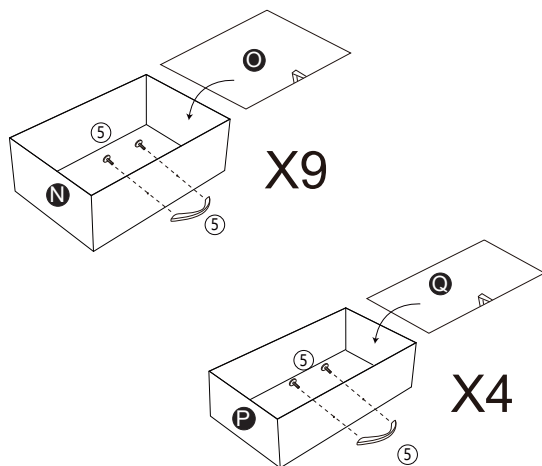

STEP 8

⑥*2

⑦*2

⑧*1

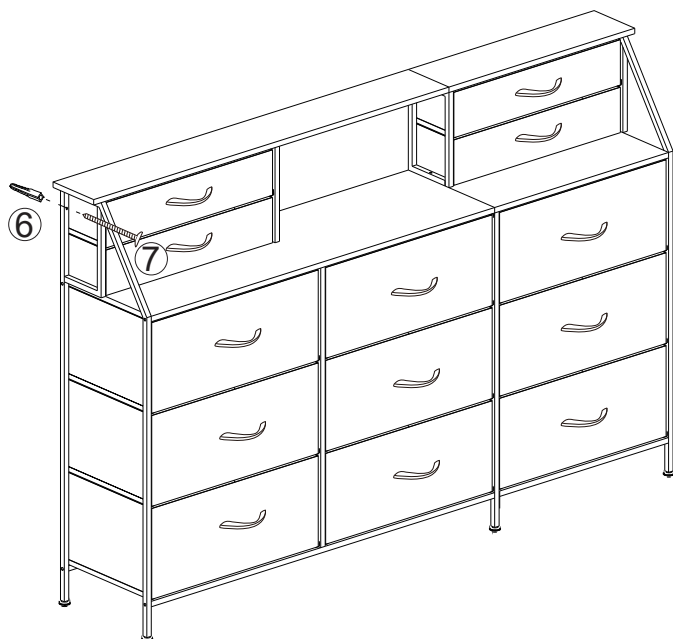

HELP CENTER

WE STAND BEHIND THE QUALITY OF OUR PRODUCT

1. If you have any other issues with your item(s), please feel free to contact us! We will always do our best to come up with a solution that you will be happy with.
2. Please get in touch with our customer service team before returning the item(s).
3. Please do not throw away the original box(es) if you have not finished assembling and confirmed no quality issues.

RETURN POLICY

Length of return period:

You can return the item(s) within 30 days of purchase.

In the meanwhile, everything you purchased from us comes with a one-year warranty.

Who is responsible for the return shipping fee:

We will cover the return shipping fees if:

1. Your item has a manufacturing defect in materials or workmanship. For example, material cracking or screw hole misalignment. We will send you a prepaid shipping label after you send us photos or videos of the defects.
2. Your item has been damaged in transit. For example, metal part is broken or product is damaged. We will send you a prepaid shipping label after you send us photos of the damage.
3. You receive the wrong box(es) due to a warehouse error, We will send you a prepaid shipping label after you send us photos of the item(s), shipping label(s) and words(SKU) on the outer box(es).

* However, we still hope to work with you for a better solution instead of a return. Please don't hesitate to contact our customer service team.

Customer will cover the return shipping fees if:

1. You don't like the item(s) after receiving the box(es).
2. You no longer need the item(s) but have received the box(es).
3. You buy the item(s) by mistake but have received the box(es).
4. Order/shipment cancellation failed, and you have received the box(es).

Return Request

In order to get a full refund as described in this return policy, all items must be:

1. In a brand new/unused condition. Please provide photos before and after packaging.
2. All accessories and parts must be firmly packed in all original packaging before returning. If your return does not meet these requirements, you may not receive a full refund.

When can I receive a refund?

After you return it using the prepaid shipping label we provided and inform us, the refund will be issued once the package(s) have been returned to our warehouse.

What if the product is damaged/defective outside of the valid return period?

We want you to be a happy customer. Please reach out to us via email or text, and we will work on a solution to ensure your satisfaction.