

ASSEMBLY INSTRUCTIONS

DESCRIPTION: CONSOLE TABLE 3 DRAWERS

IMPORTANT NOTE

****PLACE ALL PARTS ON A CLEAN AND SMOOTH SURFACE SUCH AS A RUG OR CARPET TO AVOID THE PARTS FROM BEING SCRATCHED**

****BEFORE YOU BEGIN, KINDLY FOLLOW THE ASSEMBLY INSTRUCTIONS STEP BY STEP**

****DO NOT TIGHTEN ALL SCREWS AND BOLTS UNTIL THE CABINET IS FULLY SET-UP**









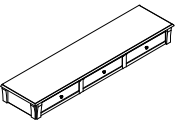

PLEASE DO NOT RETURN PRODUCT TO THE STORE

ASSEMBLY INSTRUCTIONS

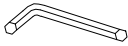
DESCRIPTION: CONSOLE TABLE 3 DRAWERS

CARTONS ONLY ONE / HARDWARE LIST

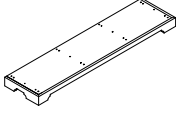
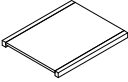
PART LISTS				HARDWARE LIST			
NO	DESCRIPTION	SKETCH	Q'TY	NO	DESCRIPTION	SKETCH	Q'TY
A	TOP TABLE		1 PC	1	BOLT Ø5/16*32mm		20 PCS
				2	WASHER Ø1/4*19mm		20 PCS
B	LEFT LEG		1 PC	3	SPRING WASHER Ø1/4"*11mm		20 PCS
				4	ALLEN KEY M4*60mm		1 PC
C	RIGHT LEG		1 PC	5	SHELF PIN 15*5mm		12 PCS
D	MIDDLE LEGS		2 PCS	6	DOWEL 30*8mm		16 PCS
E	TABLE BASE		1 PC				
F	SHELF PANEL		3 PCS				

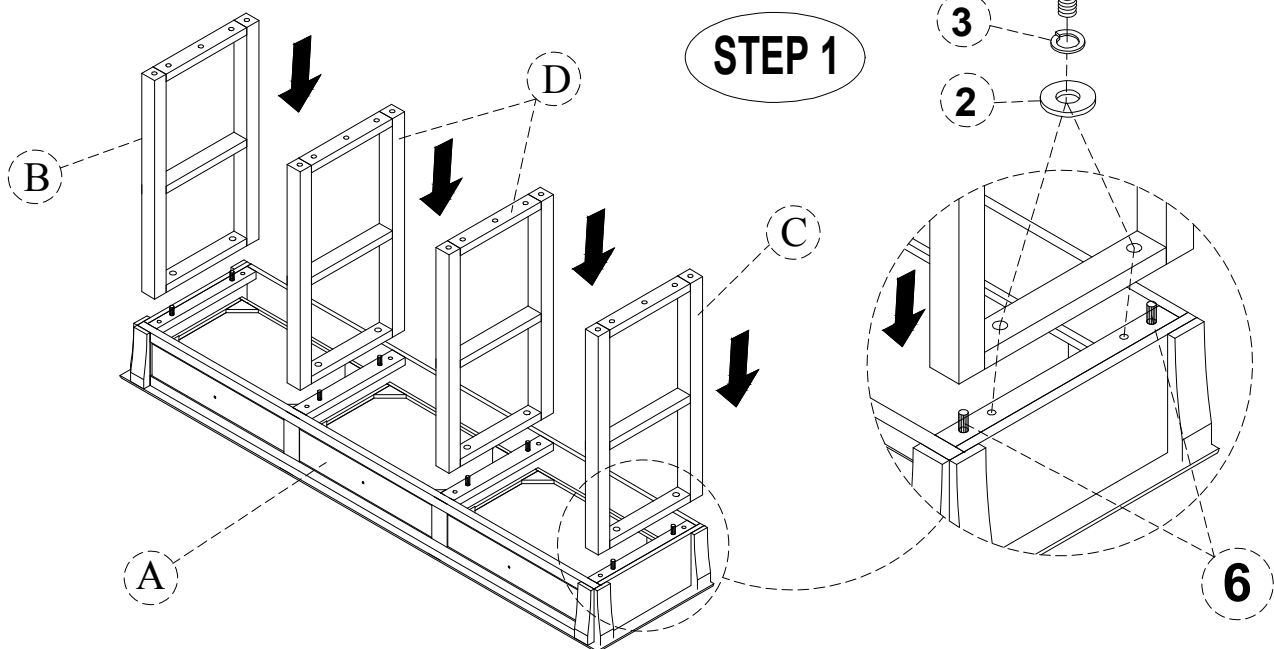

ASSEMBLY INSTRUCTIONS

DESCRIPTION: CONSOLE TABLE 3 DRAWERS

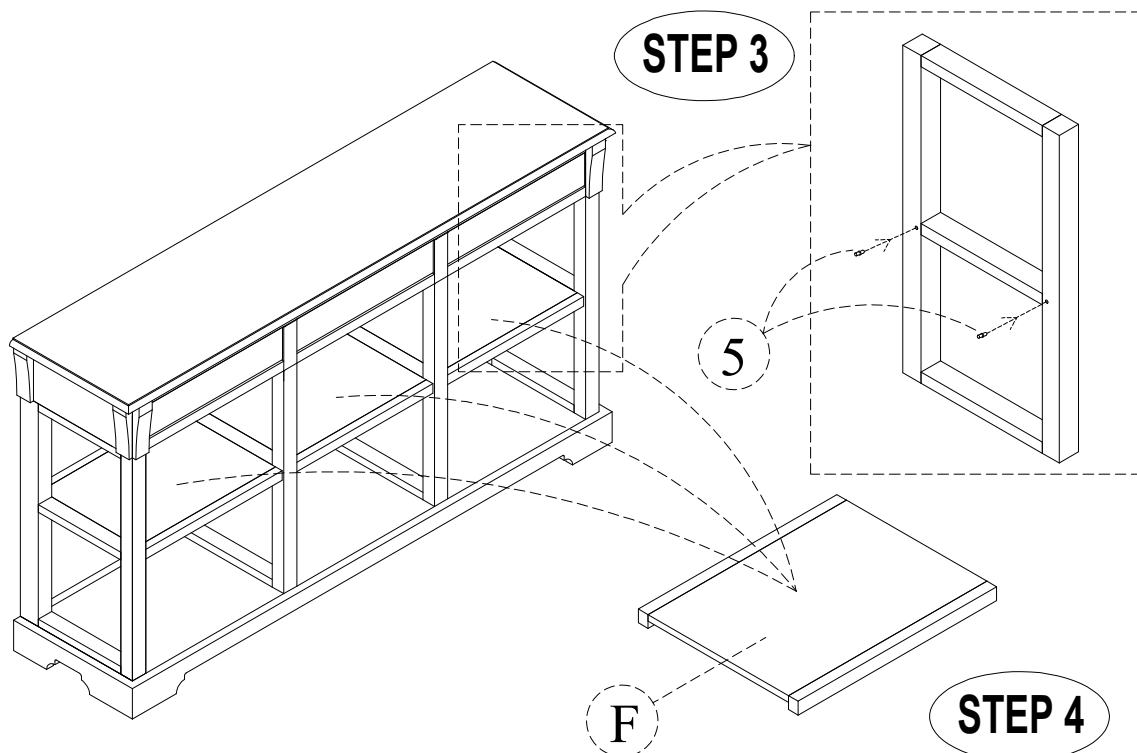
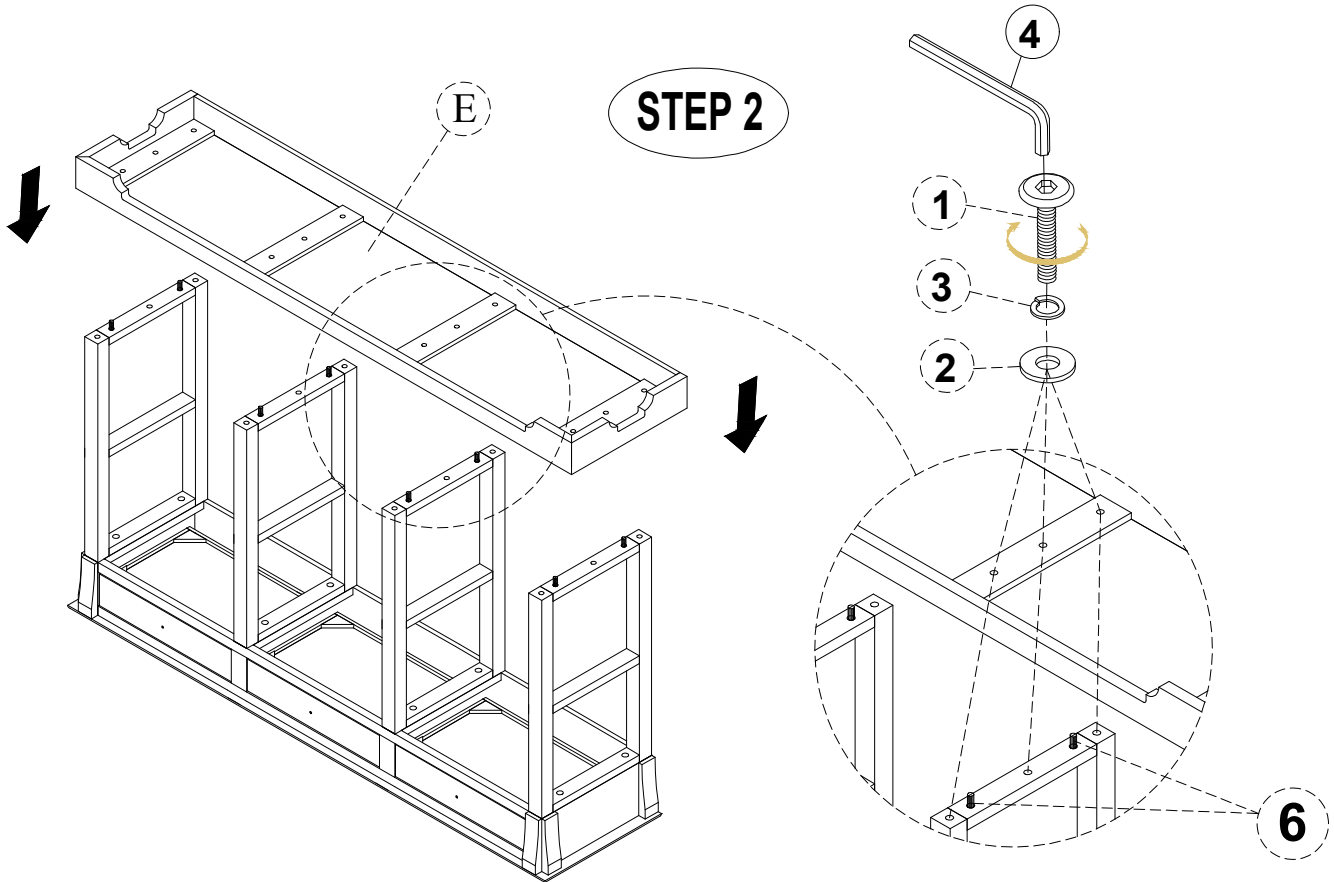

ASSEMBLY INSTRUCTIONS

DESCRIPTION: CONSOLE TABLE 3 DRAWERS

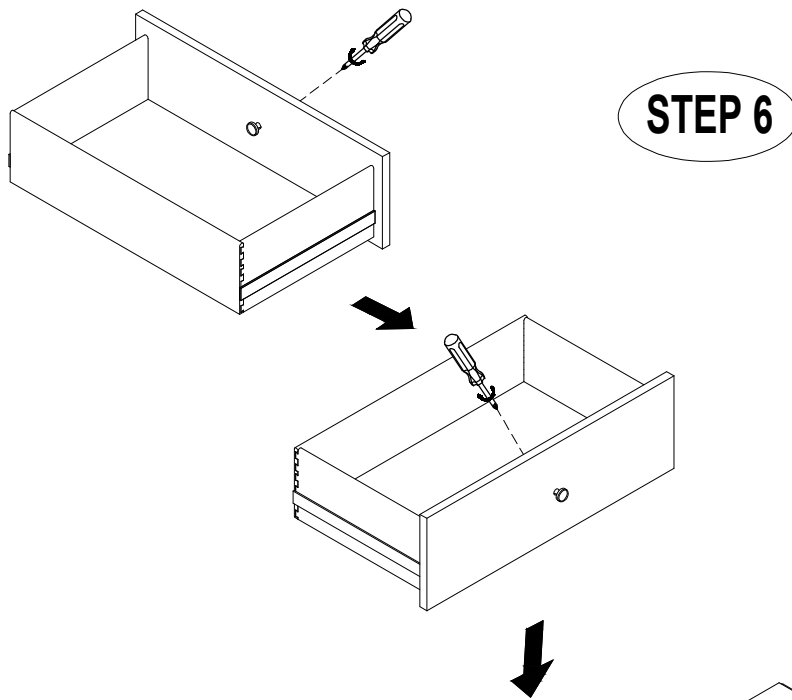

COMPLETE

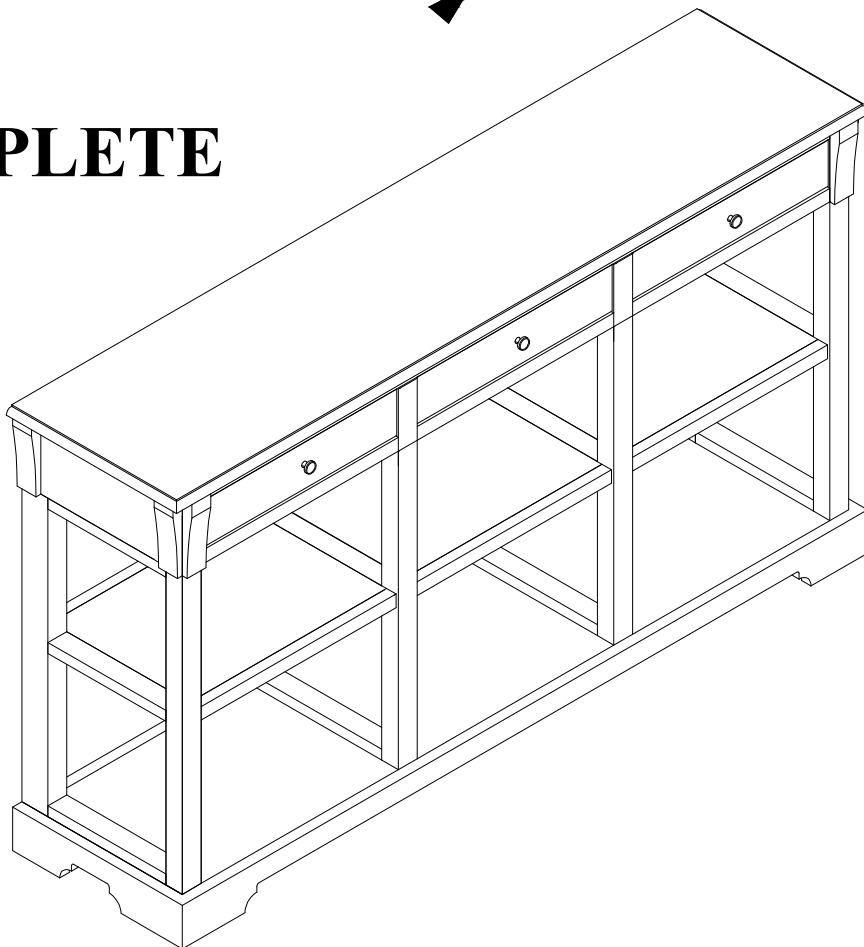

PLEASE DO NOT RETURN PRODUCT TO THE STORE