

TV STAND

Assembly Instructions - Please keep for future reference

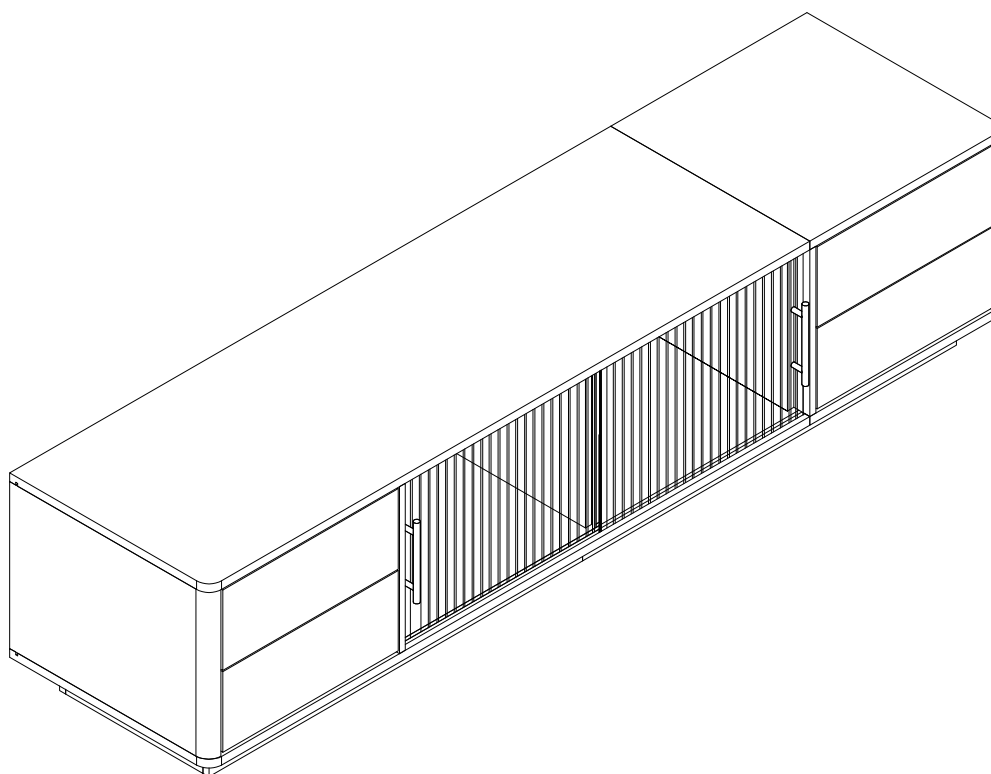

Important - Please read these instructions fully before starting assembly



Safety and Care Advice

Important – Please read these instructions fully before starting assembly

- Check you have all the components and tools listed on the following pages.
- Remove all fittings from the plastic bags and separate them into their groups.
- Keep children and animals away from the work area, small parts could choke if swallowed.
- Make sure you have enough space to layout the parts before starting.

- During assembly do not stand or put weight on the product, this could cause damage.
- Assemble the item as close to its final position (in the same room) as possible.
- Assemble on a soft level surface to avoid damaging the unit or your floor.
- Parts of the assembly will be easier with 2 people.



power drill is set on a low torque setting.

- To reduce the likelihood of damaging your product please ensure that your

Care and maintenance

- Only clean using a damp cloth and mild detergent, do not use bleach or abrasive cleaners.
- From time to time check that there are no loose screws on this unit.
- This product should not be discarded with household waste. Take to your local authority waste disposal centre.

Handy Hints

- Assemble all parts and bolts loosely during assembly, only once the product is complete should you fully tighten the bolts
- Regularly check and ensure That all bolts and fittings are tightend properly.

WARNING In order to help prevent overturning – please follow these instructions









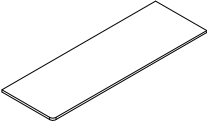
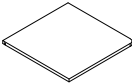
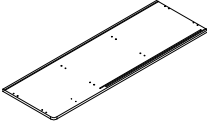
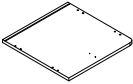
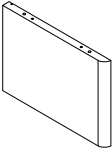
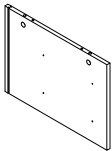
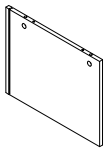
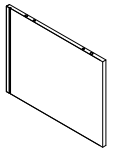
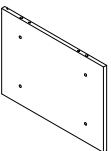
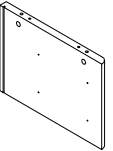
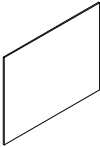
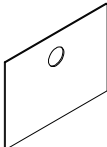
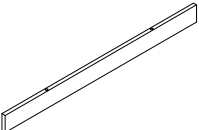
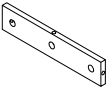
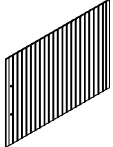
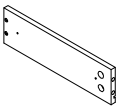
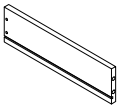
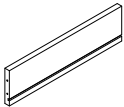
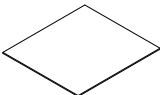

To help prevent product toppling over please follow the below steps:-

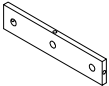
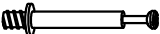
- Use the anti tip stap or wall fixing method provided (if applicable)
- Do not allow children to climb or hang on the furniture
- Do not open more than one drawer at a time
- Do not place heavy items in the top drawers
- Do not place heavy items on top of the furniture, unless the furniture has been designed for this purpose

Components - Fittings

Please check you have all the panels listed below



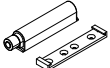



Note: The quantities below are the correct amount to complete the assembly. In some cases more fittings may be supplied than are required.

				
① x 1PC	② x 1PC	③ x 1PC	④ x 1PC	⑤ x 1PC
				
⑥ x 1PC	⑦ x 1PC	⑧ x 1PC	⑨ x 1PC	⑩ x 1PC
				
⑪ x 2PCS	⑫ x 2PCS	⑬ x 4PCS	⑭ x 2PCS	⑮ x 2PCS
				
⑯ x 4PCS	⑰ x 4PCS	⑱ x 4PCS	⑲ x 4PCS	⑳ x 2PCS
				
㉑ x 2PCS	㉒ x 2PCS			
				
M6x35mm	Ø15x10mm	6x30mm	5x40mm	M4mm
Ⓐ x 48PCS	Ⓑ x 48PCS	Ⓒ x 24PCS	Ⓓ x 12PCS	Ⓔ x 1PC
				
3.5x12mm	M6x20mm	M3mm	4x30mm	
Ⓕ x 44PCS	Ⓖ x 4PCS	Ⓗ x 1PC	Ⓘ x 16PCS	Ⓝ x 4PCS

Components - Fittings

Please check you have all the panels listed below

Note: The quantities below are the correct amount to complete the assembly. In some cases more fittings may be supplied than are required.

	 4x15mm	 300mm	 300mm	
Ⓚ x 4PCS	Ⓛ x 4PCS	Ⓜ x 8PCS	Ⓝ x 8PCS	Ⓞ x 2PCS
 3.5x14mm				
Ⓟ x 16PCS	Ⓠ x 16PCS			

Tools required

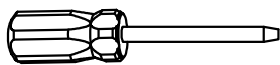
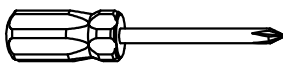

Using Camlocks

Step 1

Connect the male camlock as directed in the assembly instructions using a screwdriver.

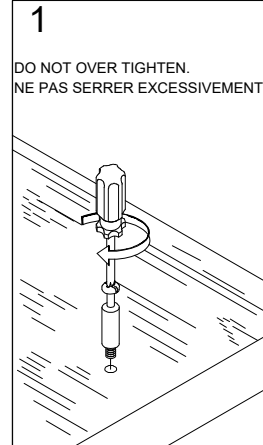

Step 2

Push the male camlock into the entry hole.

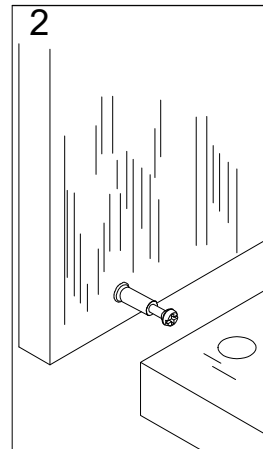

Step 3

Insert the female camlock as shown in the instruction.

Note ensure that the arrow on the top of the camlock points towards the entry hole for the male camlock.

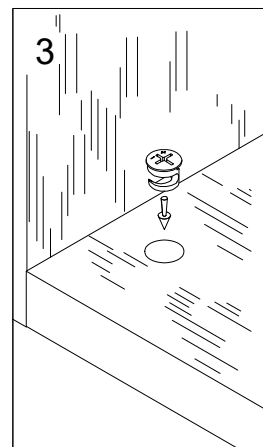

Step 4

Turn the female camlock clockwise with a screwdriver.

You should feel a click when the camlock is locked in place.

The joint is now secure.

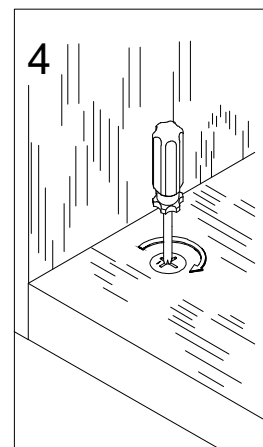

Assembly Instructions

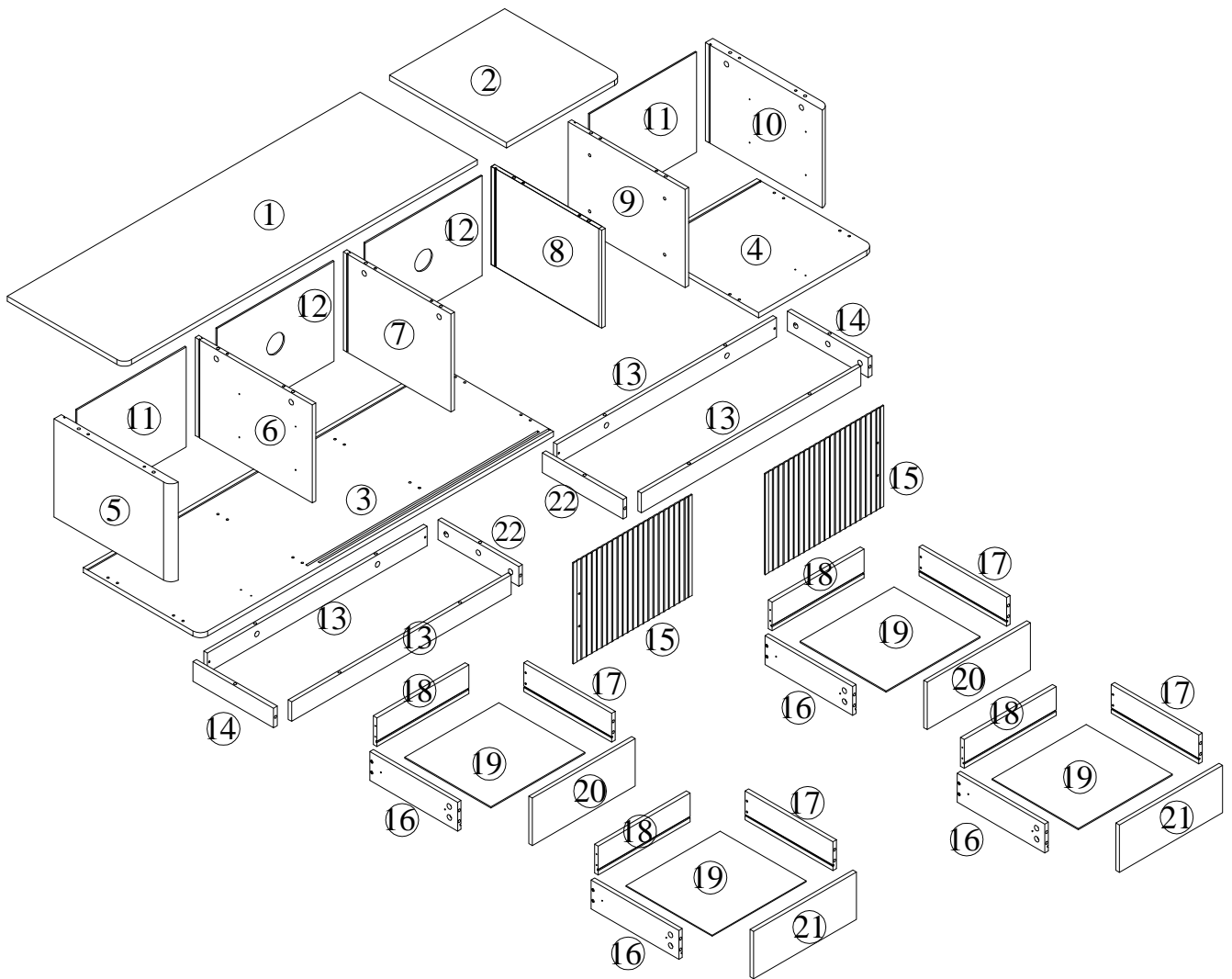

Assembly Instructions

Step 1

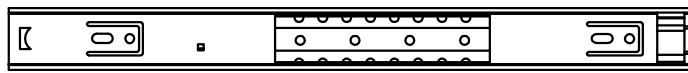
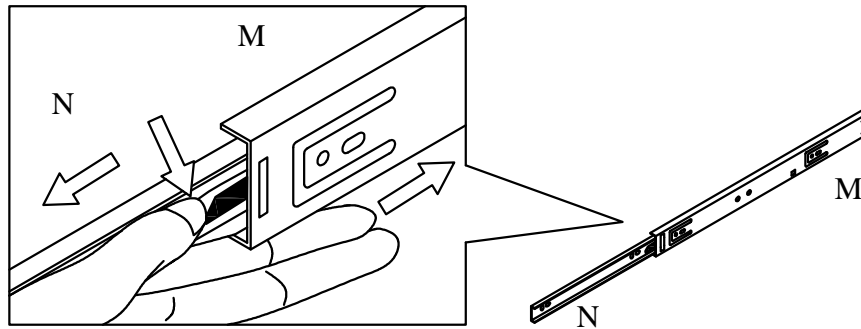

M

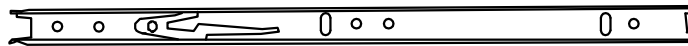

N

M	x8
300mm	

N	x8
300mm	

Step 2

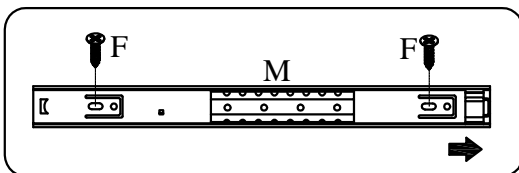
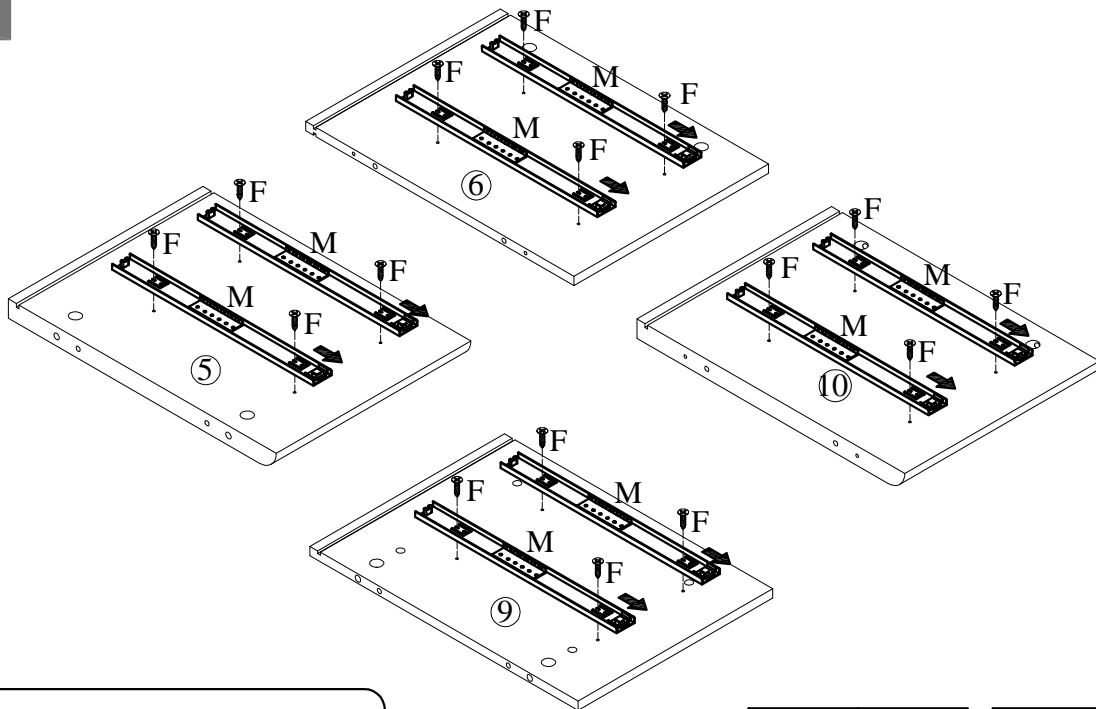

F	x16
3.5x12mm	

M	x8
300mm	

Assembly Instructions

Step 3

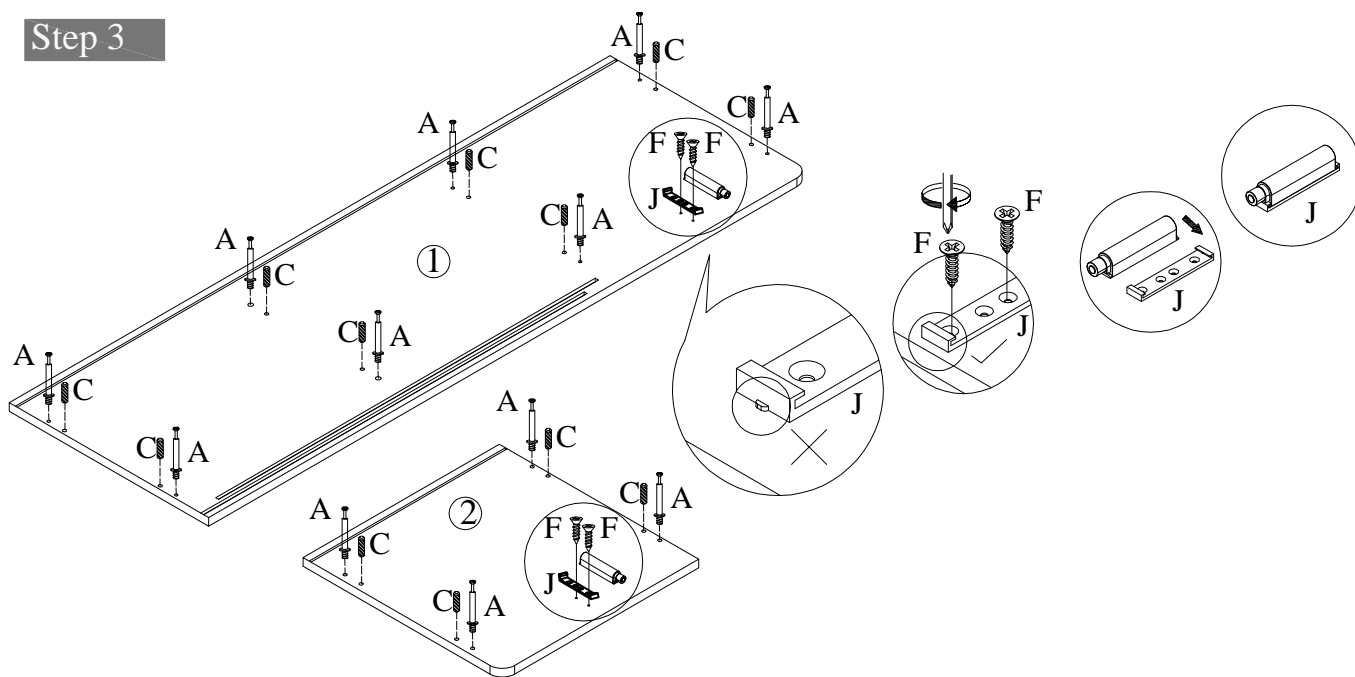

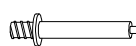
A	x12
	
M6x35mm	

C	x12
	
6x30mm	

F	x4
	
3.5x12mm	

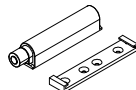
J	x2
	

Step 4

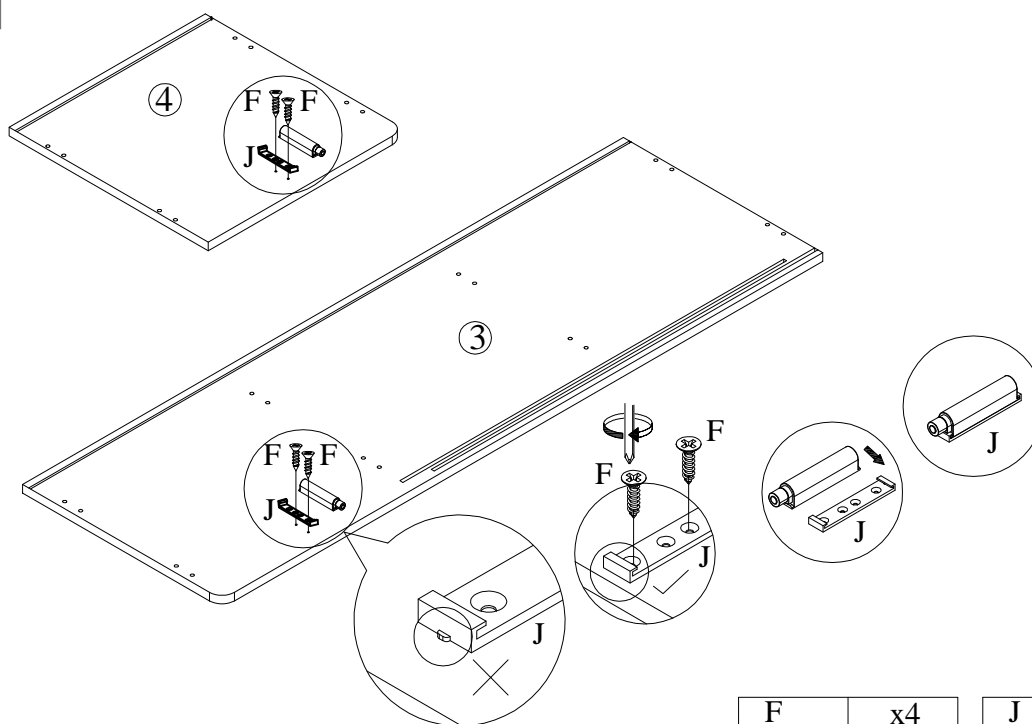

F	x4
	
3.5x12mm	

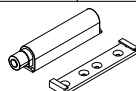
J	x2
	

Assembly Instructions

Step 5

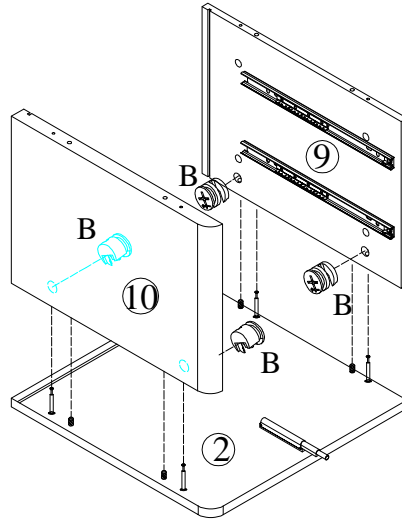

B	x4
Ø15x10mm	

Step 6

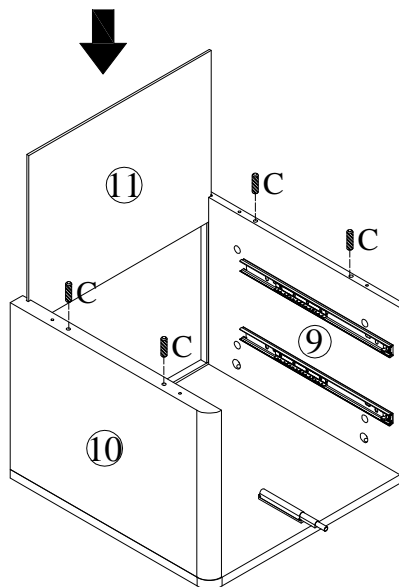

C	x4
6x30mm	

Assembly Instructions

Step 7

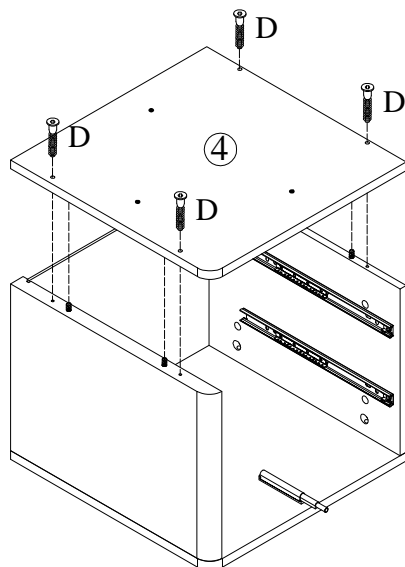

D	x4
M5x40mm	

H	x1
M3mm	

Step 8

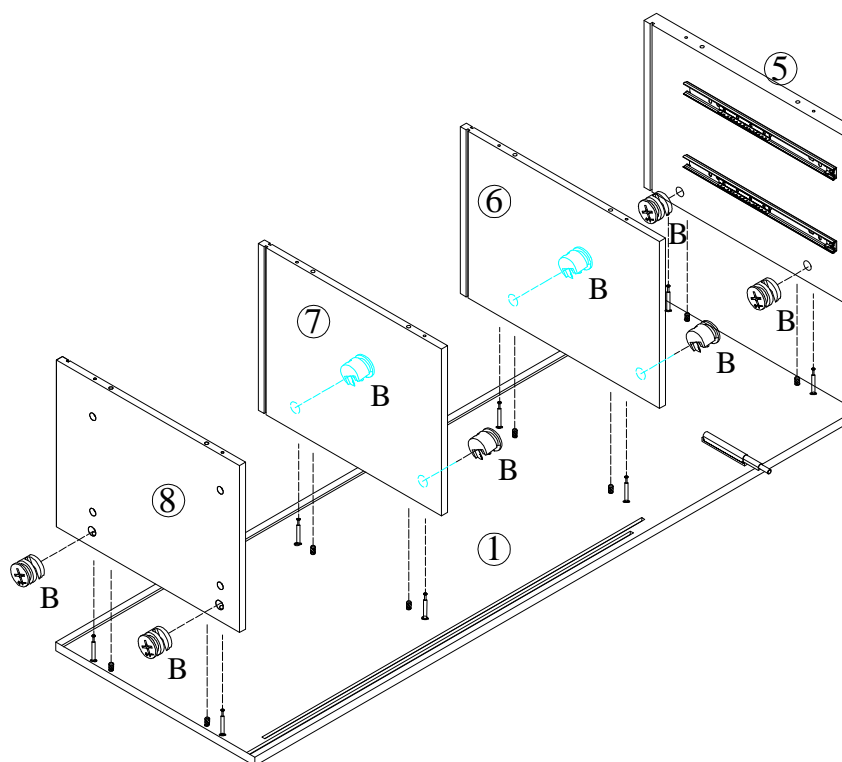

B	x8
Ø15x10mm	

Assembly Instructions

Step 9

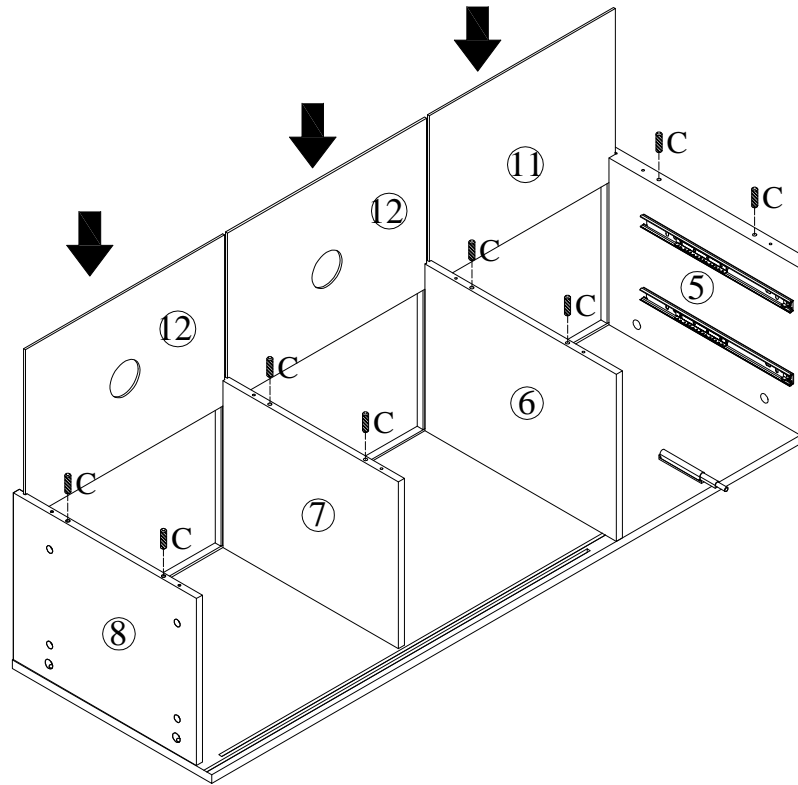

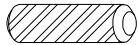
C	x8
	
6x30mm	

Step 10

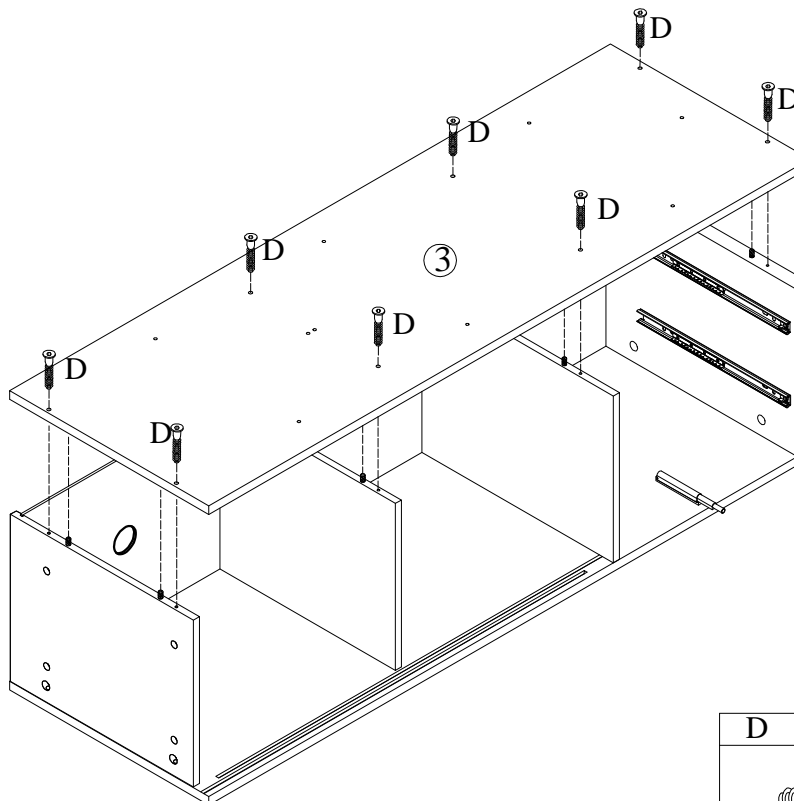

D	x8
	
M5x40mm	

H	x1
	
M3mm	

Assembly Instructions

Step 11

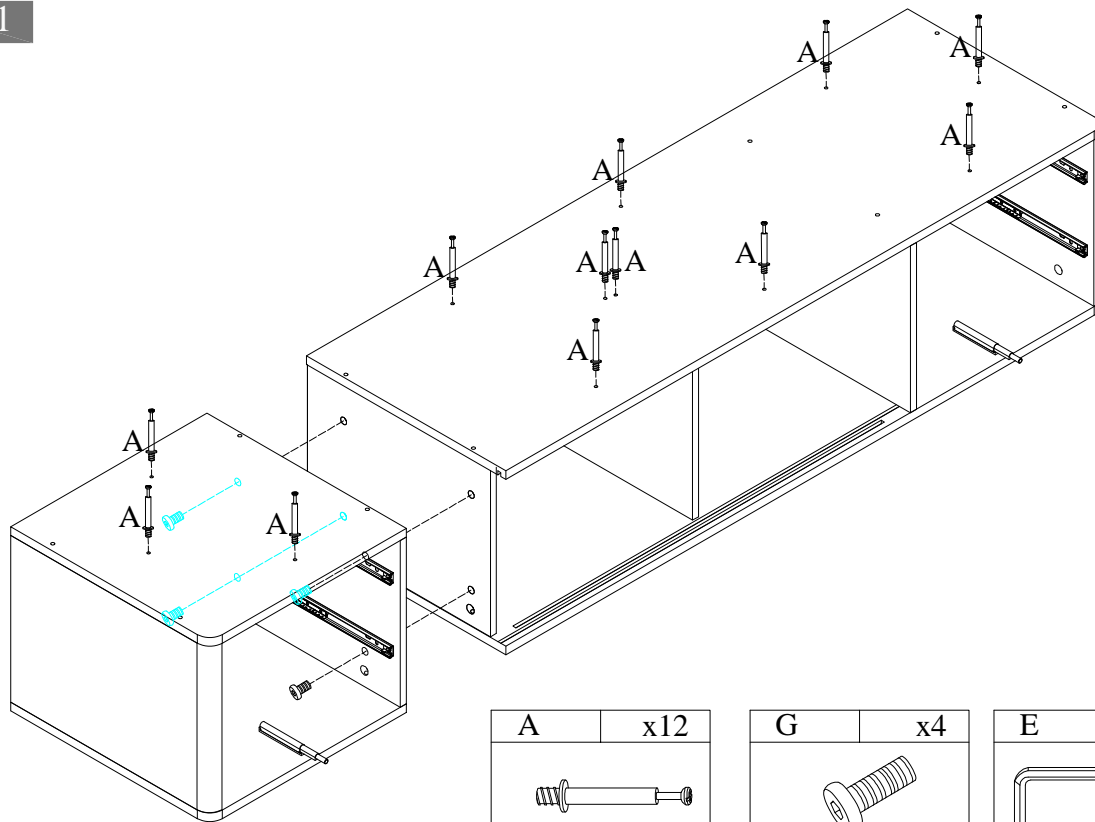

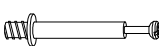
A	x12
	
M6x35mm	

G	x4
	
M6x20mm	

E	x1
	
M4mm	

Step 12

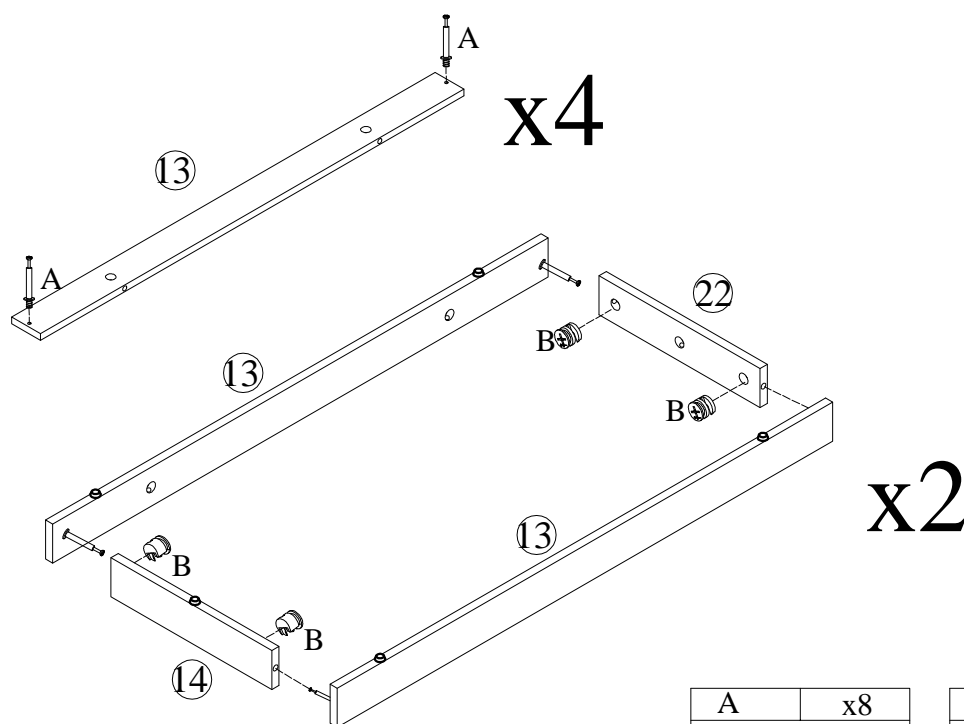

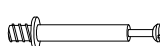
A	x8
	
M6x35mm	

B	x8
	
Ø15x10mm	

Assembly Instructions

Step 13

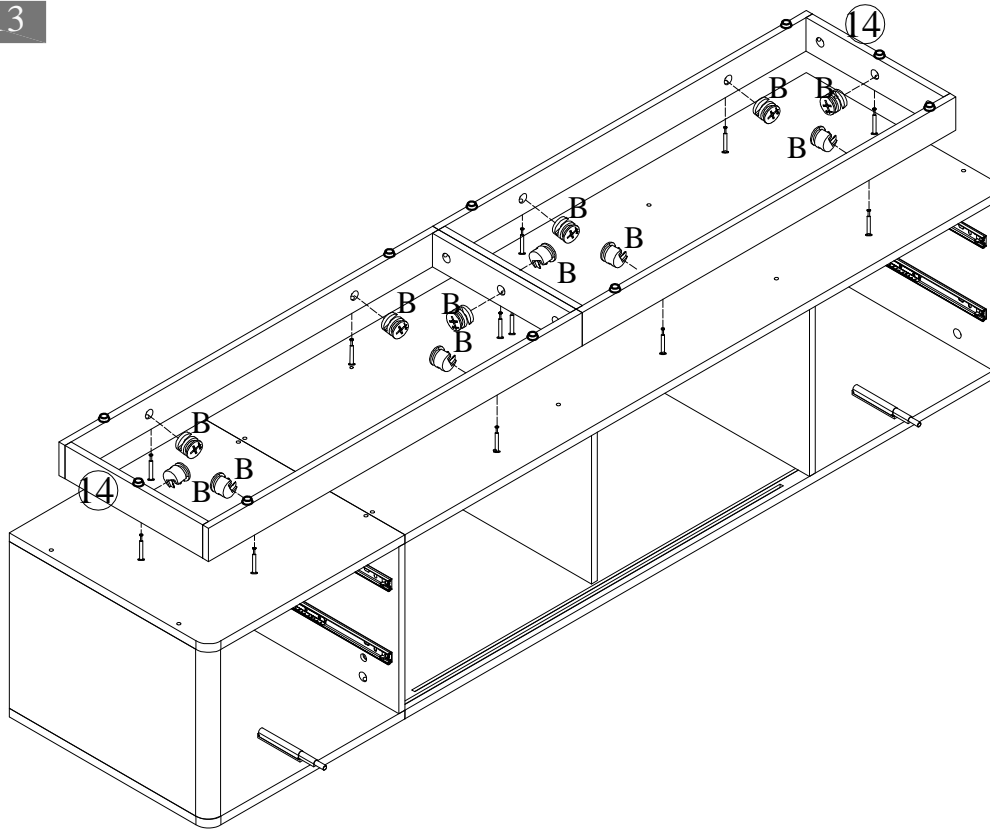

B	x12
Ø15x10mm	

Step 14

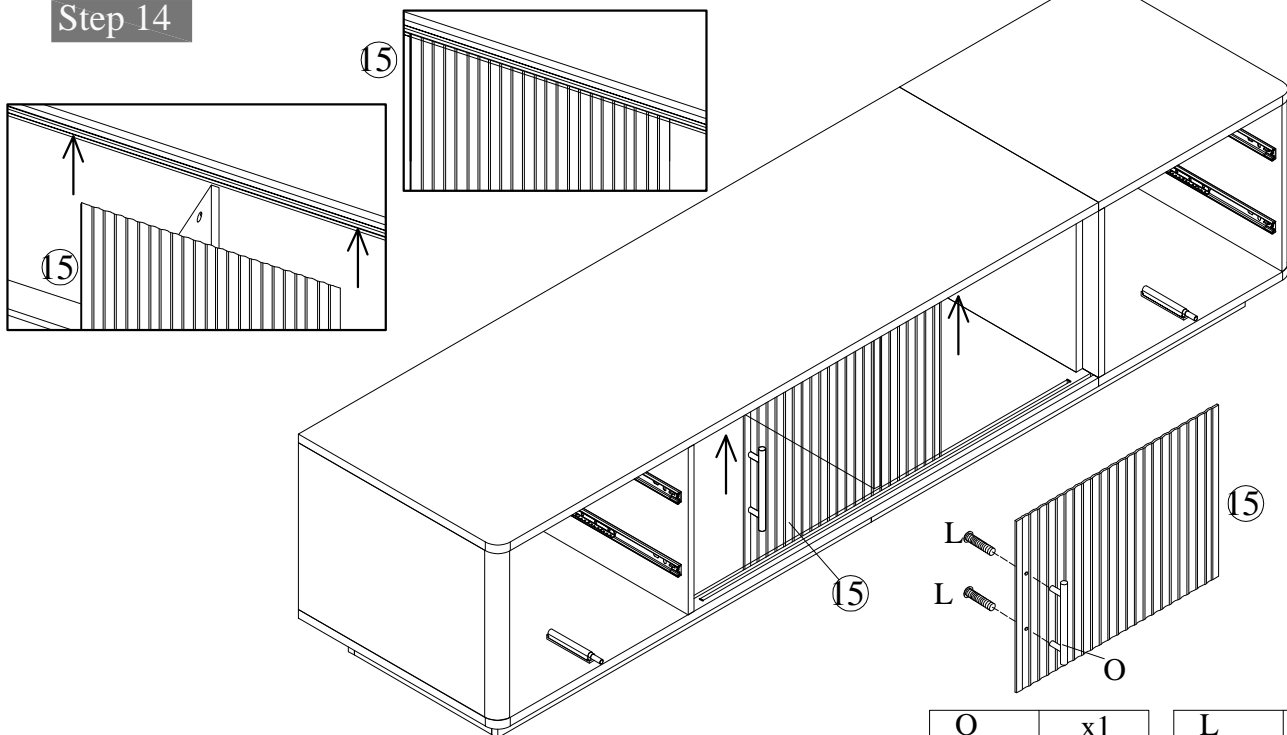

O	x1

L	x2
4x15mm	

Assembly Instructions

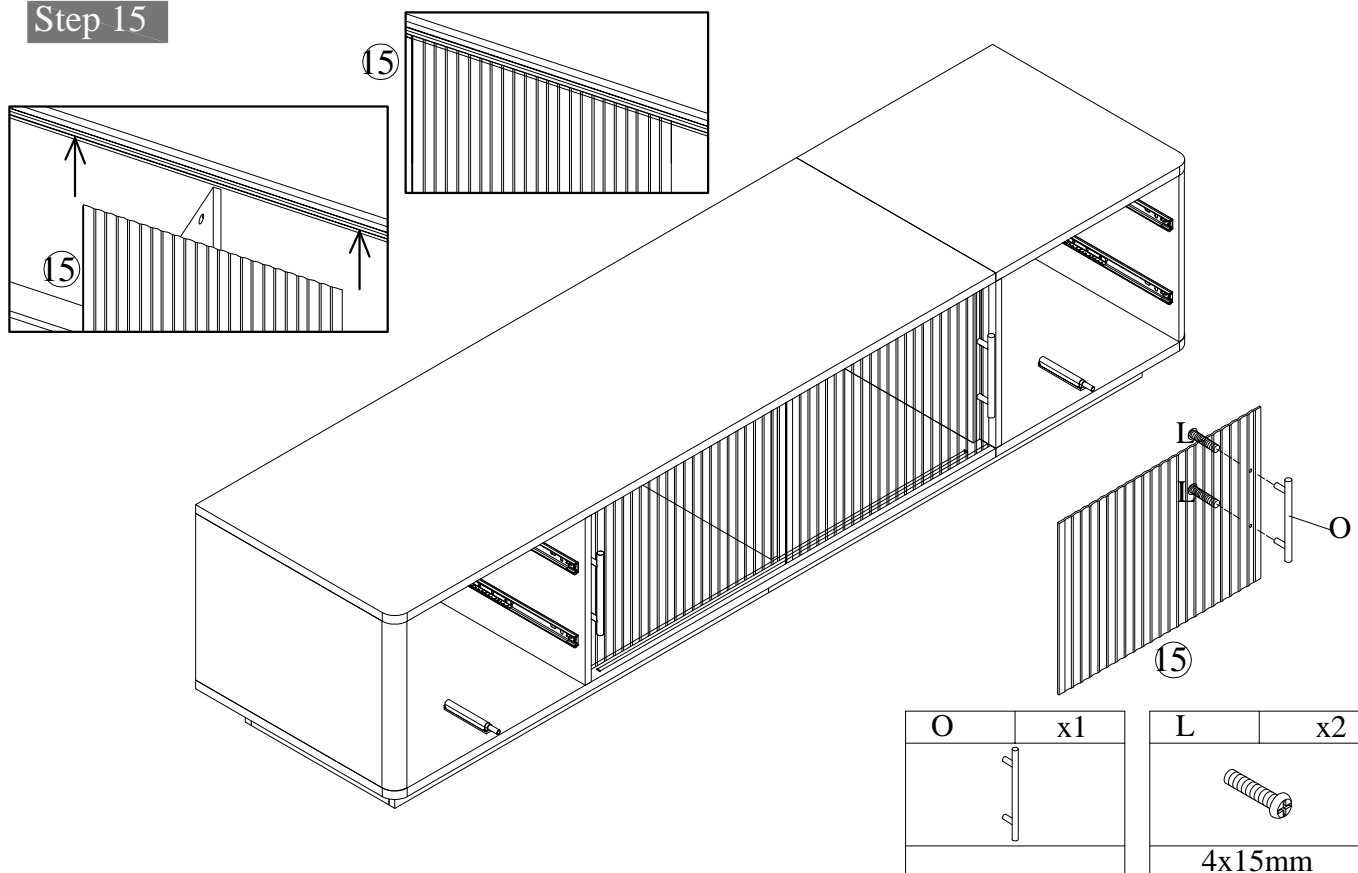

Step 15

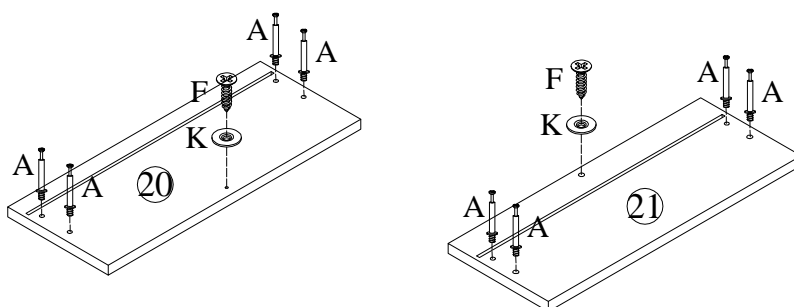

Step 16

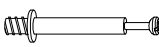

x2

A	x16	F	x4	K	x4
					
M6x35mm		3.5x12mm			

Assembly Instructions

Step 17

x4

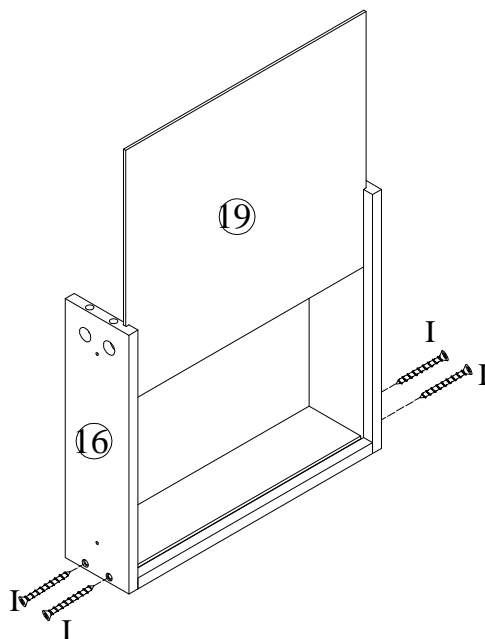

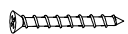
I	x16
	
4x30mm	

Step 18

x2

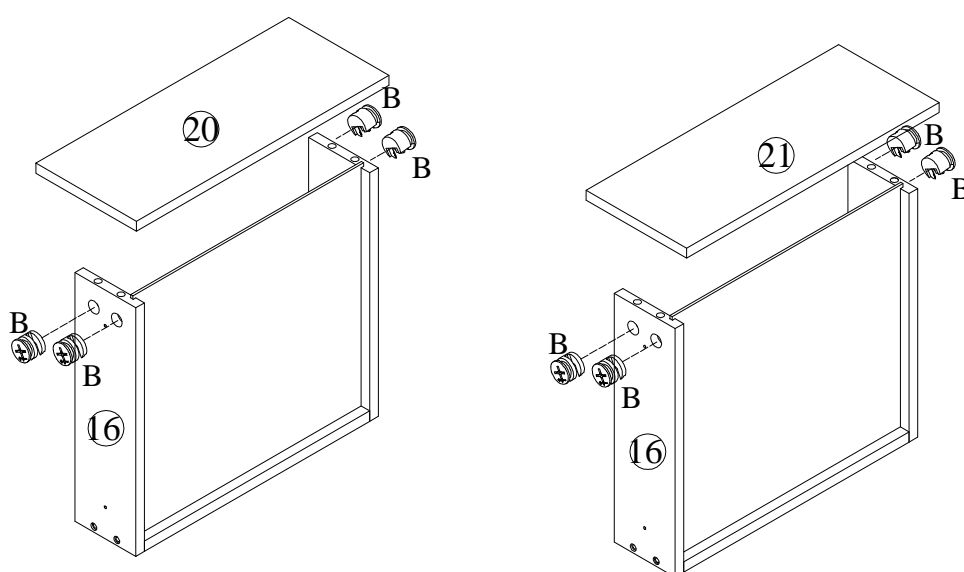

B	x16
	
Ø15x10mm	

Assembly Instructions

Step 19

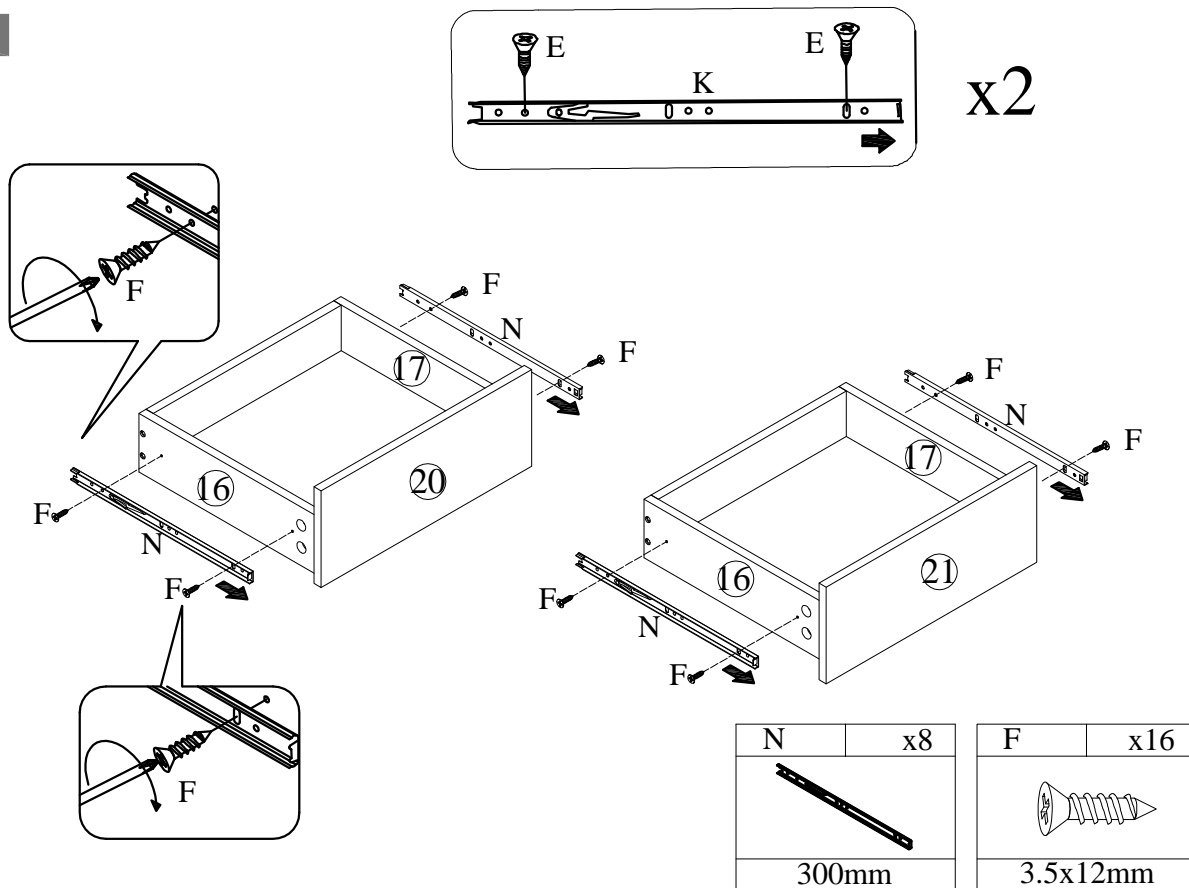

Step 20

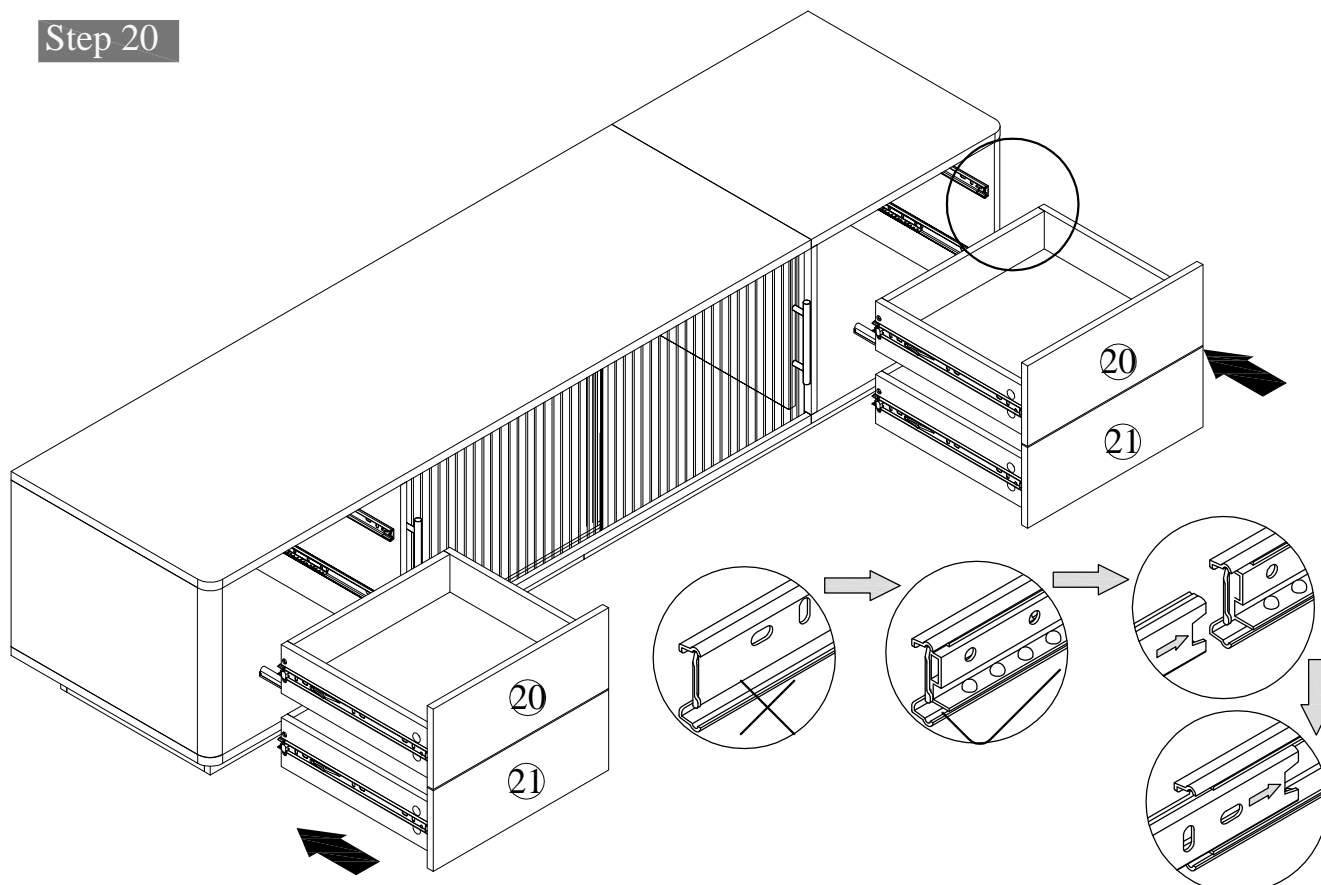

Assembly Instructions

Step 21

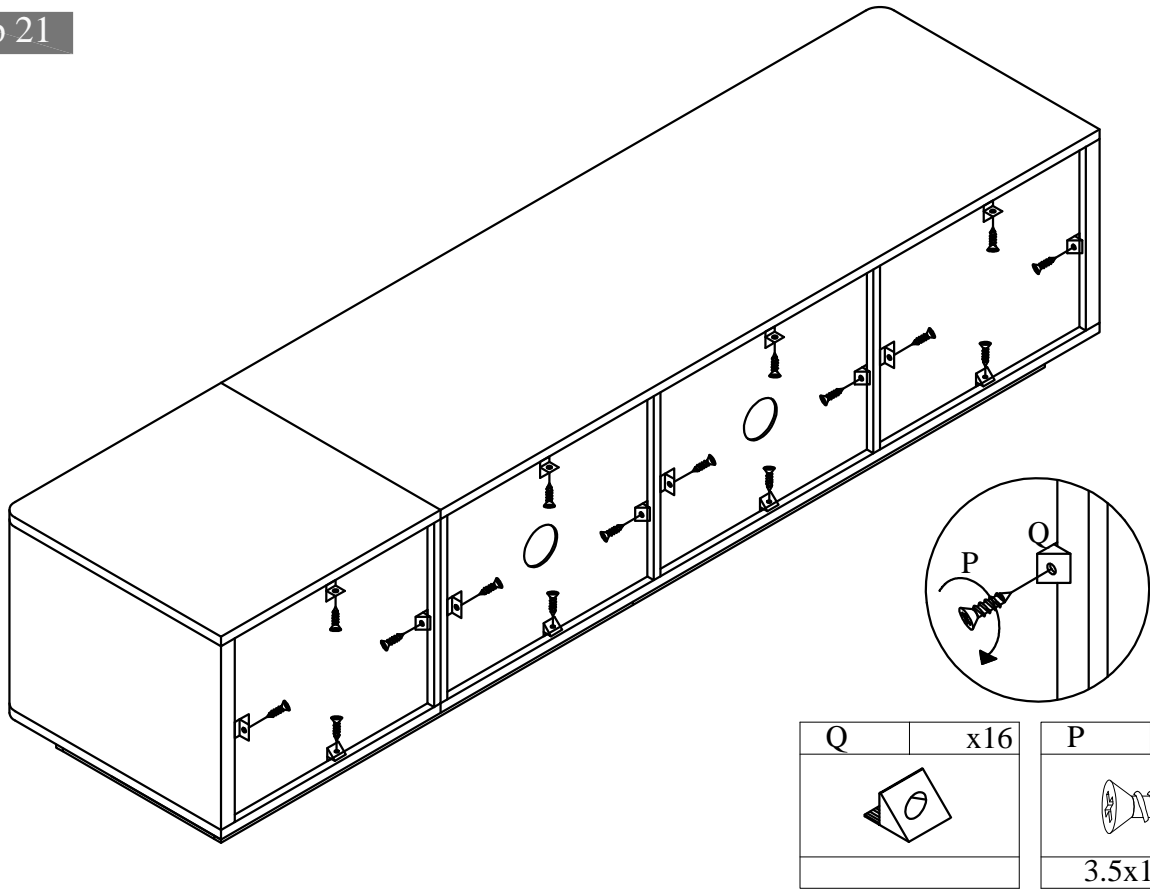

Step 22

