



PLEASE READ BELOW BEFORE PROCEEDING WITH YOUR ASSEMBLY

Unless you're particularly adept at assembling Flatpack/Knockdown Furniture, we understand building ready to assemble furniture can be a frustrating experience for some and you'll probably spend at least half a day per item. No need to panic, though! Here are some tips on assembling flat-pack furniture so you're not left with an impossible Lego project and give up in frustration. Follow these tips for your item and you'll end up with beautiful, fully-assembled furniture!

- Do Not throw away packaging material until assembly is complete.
- Assemble item on a soft surface, such as cardboard or carpet, to protect finish.

- Choose a spacious, open area near where the piece will be located. It is easier to move parts than to relocate the furniture after it is fully assembled, depending on its size and weight.
- Organize everything and count it twice. If you organize the items by parts, you'll find it much easier to grab each piece as you build.
- Check each one for cracks or flaws, such as improperly drilled holes, and count multiple parts. If there are any problems or missing pieces, contact the manufacturer with the part number, model number of the finished piece, and a description of the problem to arrange a replacement.
- It is best to use any tools the kit provides, such as a hex key, because they may be specially sized for that piece of furniture. But when in need, a Phillips-head screwdriver & Power Drill are highly suggested for large projects.
- Read the entire list of instructions, arranging your parts in order of use as you go.
- Finally, Enlist a help from friends and family since proper assembly of most items require 2 people.

ASSEMBLY INSTRUCTION

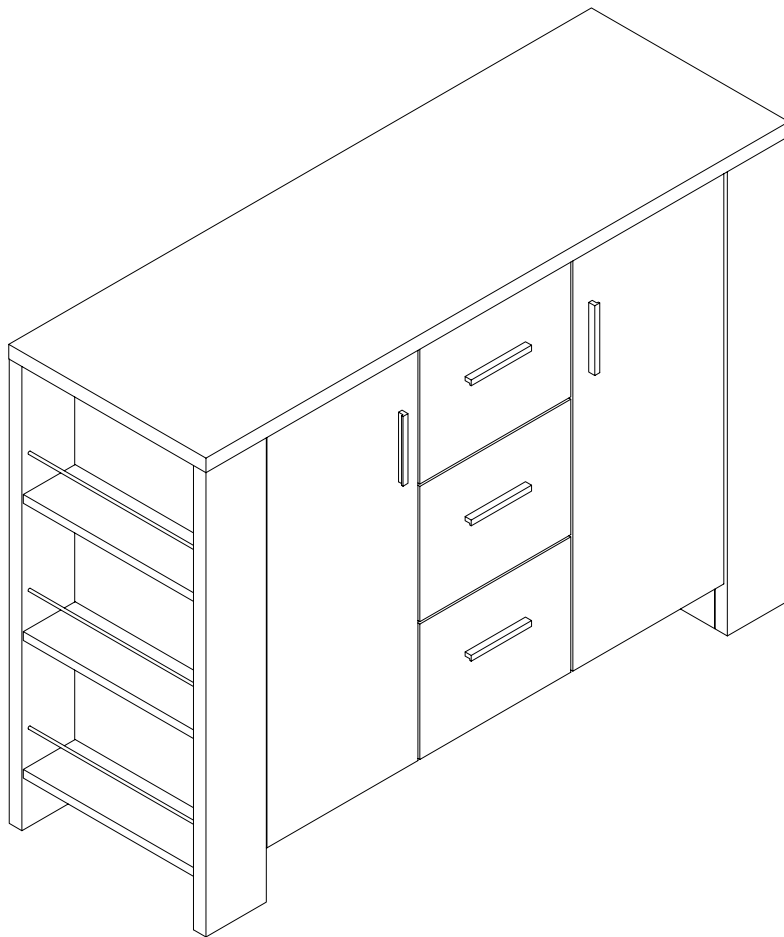



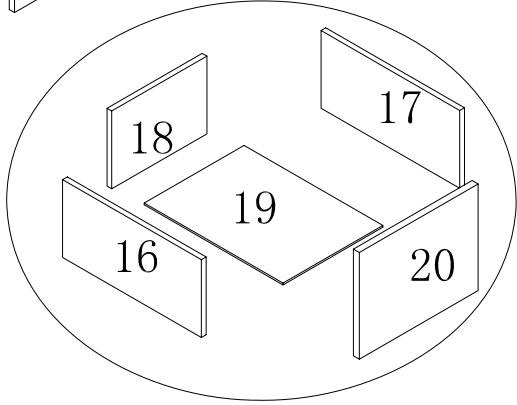
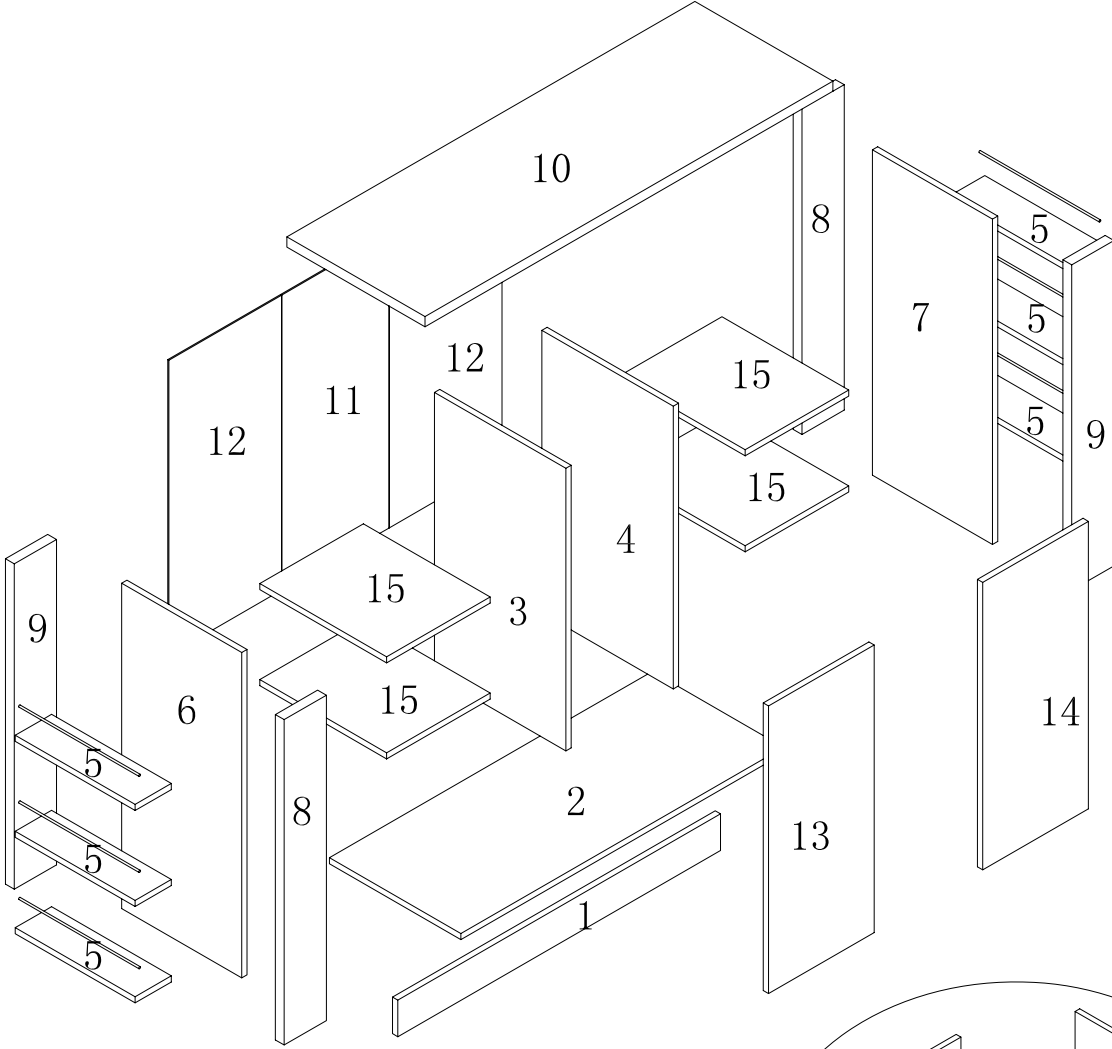







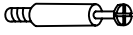



PARTS IDENTIFICATION

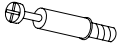

X3

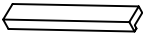
(1)	1pc	(8)	2pcs	(15)	4pcs
(2)	1pc	(9)	2pcs	(16)	3pcs
(3)	1pc	(10)	1pc	(17)	3pcs
(4)	1pc	(11)	1pc	(18)	3pcs
(5)	6pcs	(12)	2pcs	(19)	3pcs
(6)	1pc	(13)	1pc	(20)	3pcs
(7)	1pc	(14)	1pc		

HARDWARE IDENTIFICATION

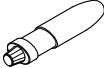
A		∅15	35pcs
B		L29	35pcs
C		∅8×25	32pcs
D		∅35	4pcs
E		∅4×16	16pcs
F		∅4×40	4pcs
G		∅5×350	6pcs
H		Z1016	60pcs
I		∅5	16pcs
J		ET12	12pcs
K		L20	12pcs
L		∅4×30	12pcs
M		∅18	16pcs
N		64#	5pcs
O		M4×22	10pcs
P		∅5×9	6pcs
Q		∅16	4pcs
R		Glue: For securing please apply to wood dowel first before inserting into panel	1pc

ASSEMBLY INSTRUCTION

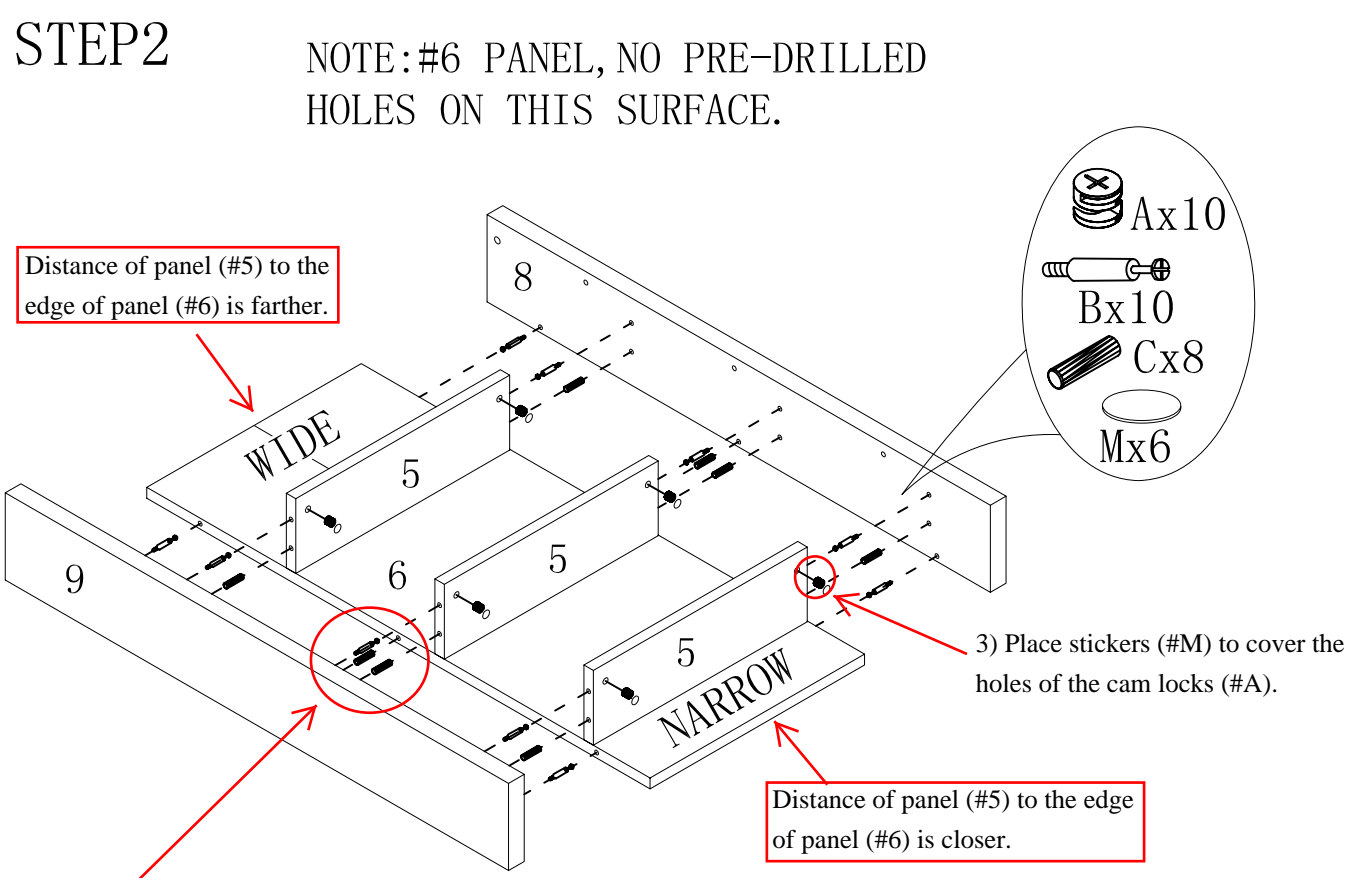
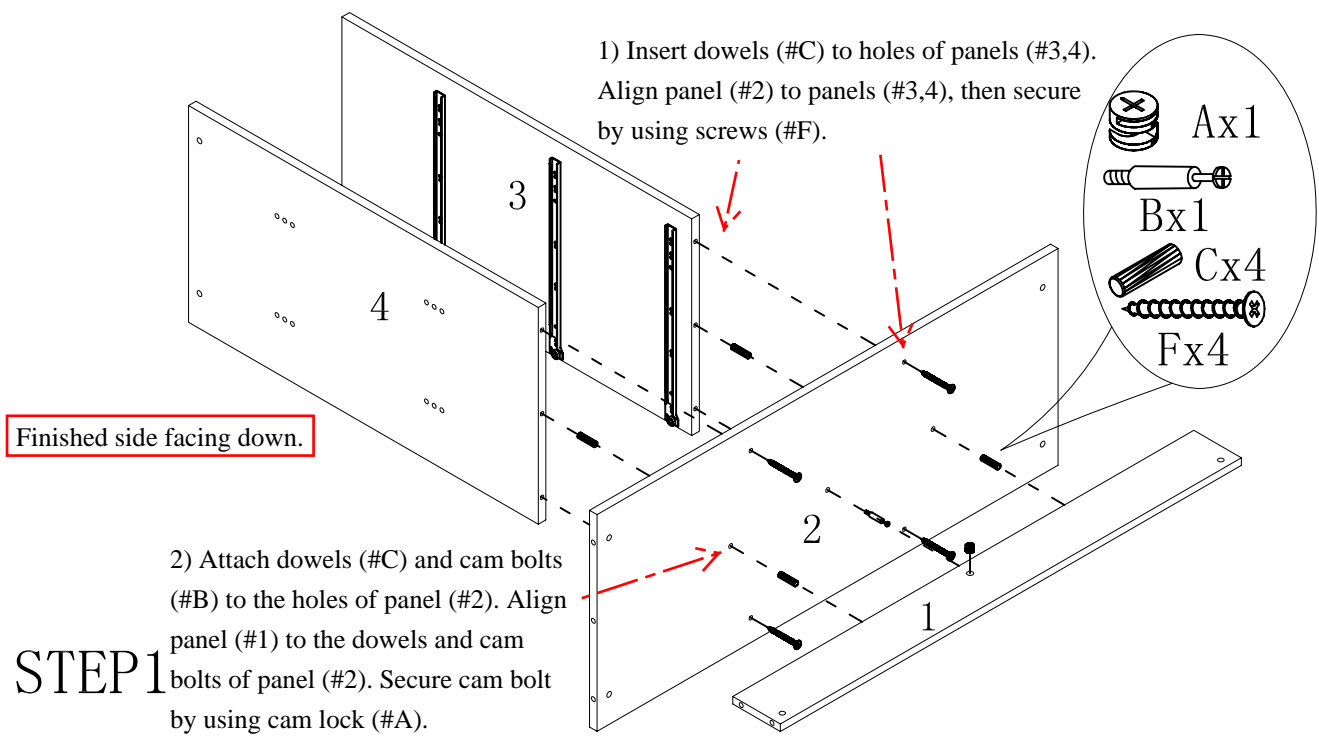

- 1) Attach cam bolts (#B) and dowels (#C) to the holes of panels (#8,9) as shown in the diagram.
- 2) Align panels (#8,9) to the holes of panels (#6) and panels (#5). Make sure to align panel (#5) to the cam bolts (#B) and dowels (#C) of panels (#8,9) when they are aligning to panels (#6).

ASSEMBLY INSTRUCTION

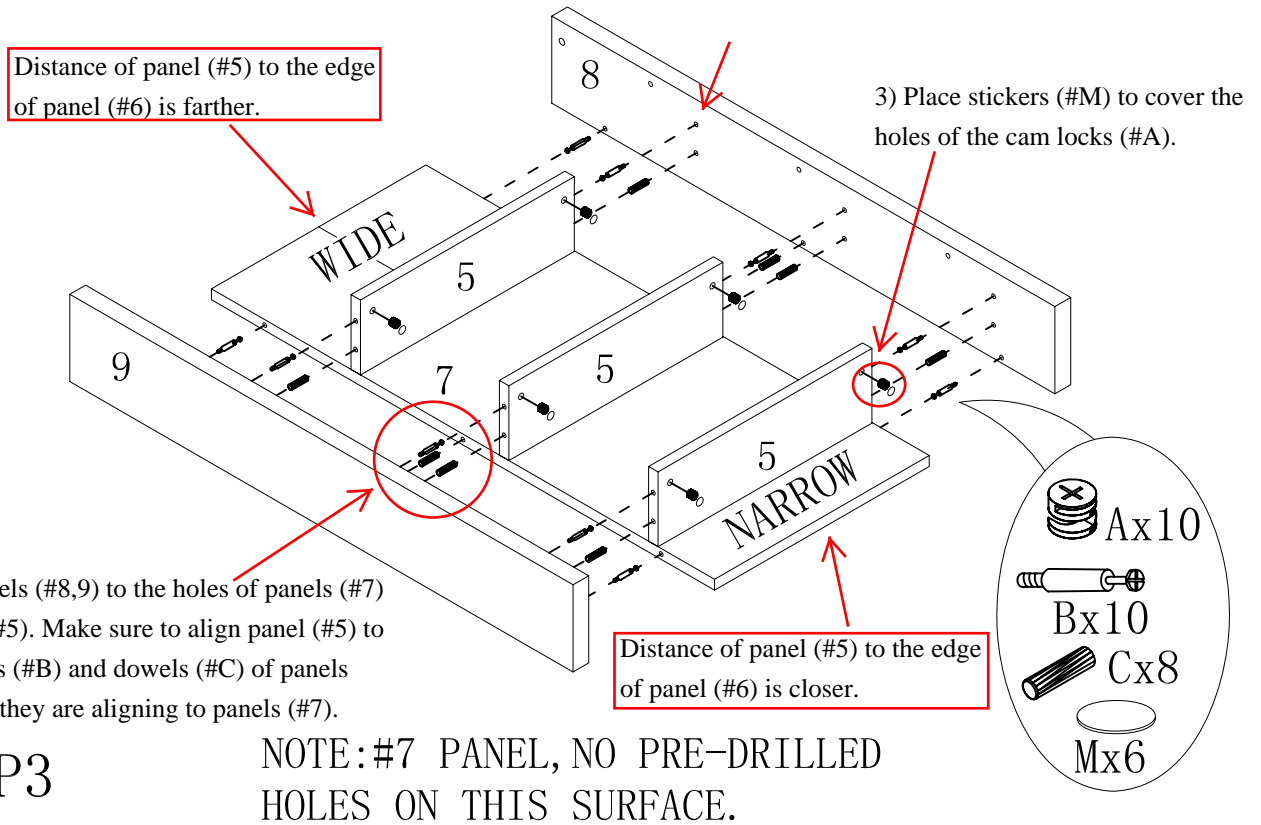

STEP4

Attach cam bolts (#B) and dowels (#C) onto panels (#6,7). Align panels (#6,7) to the holes of bottom panels (#1,2). Secure by using cam locks (#A).

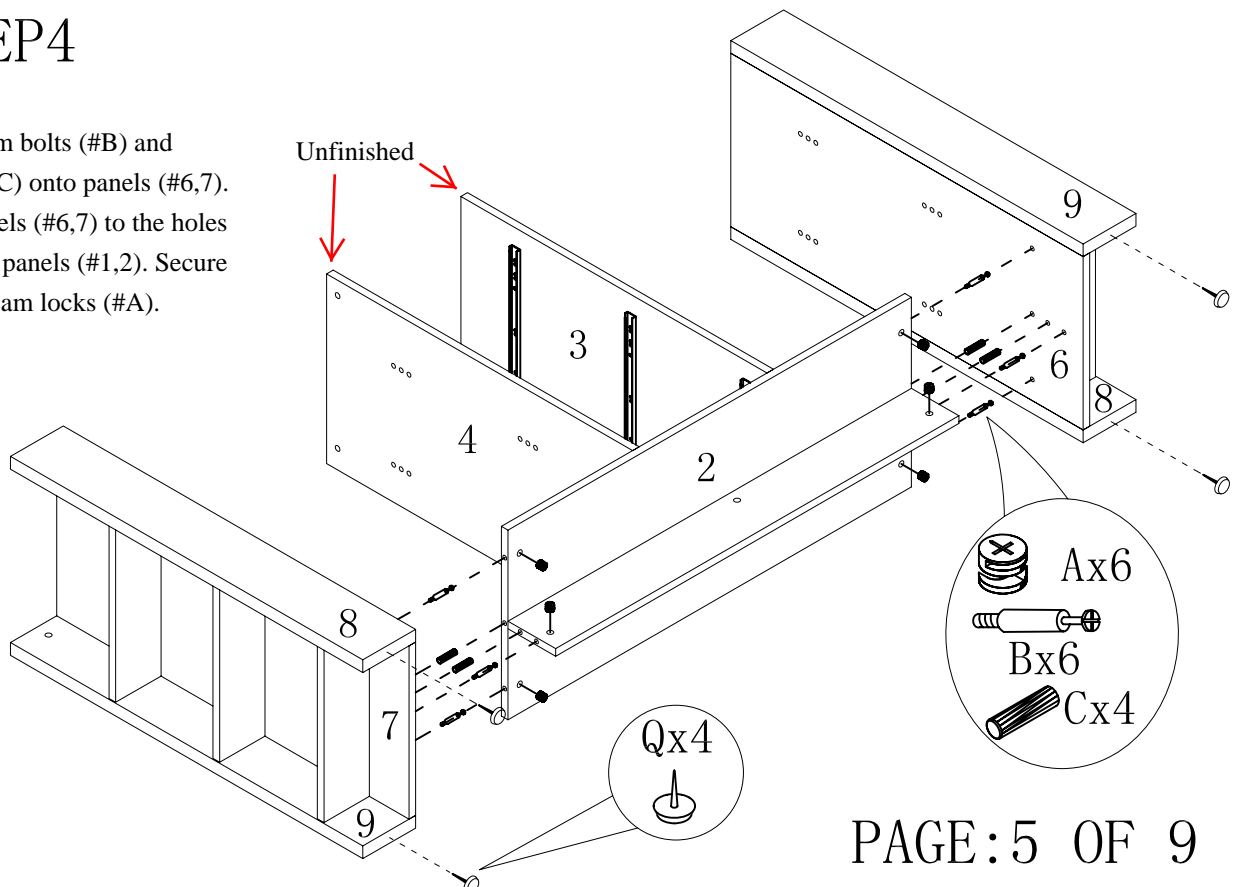

ASSEMBLY INSTRUCTION

STEP 5

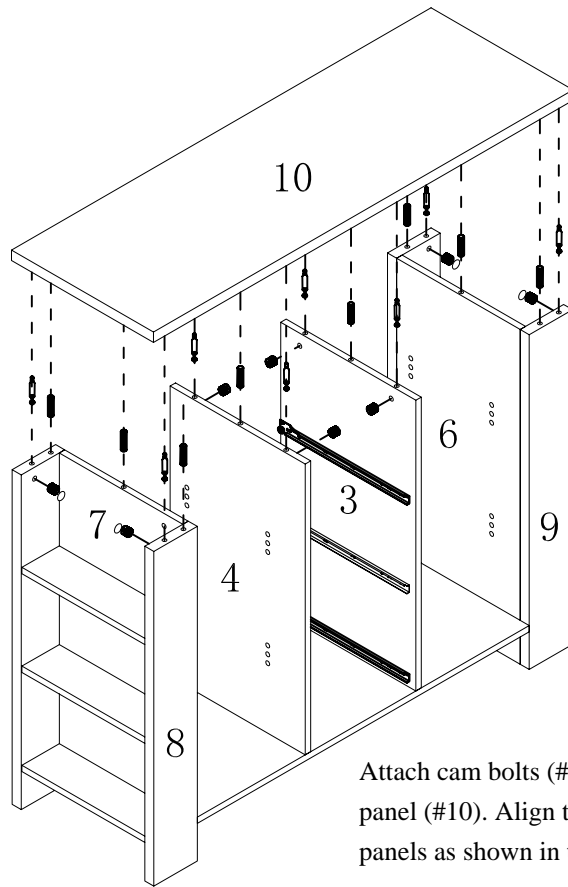

Attach cam bolts (#B) and dowels (#C) to the holes of the top panel (#10). Align top panel (#10) to the holes of the base panels as shown in the picture. Secure by using cam bolts (#A).

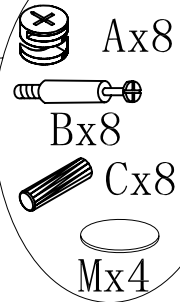

STEP 6

Completely finished on this side.

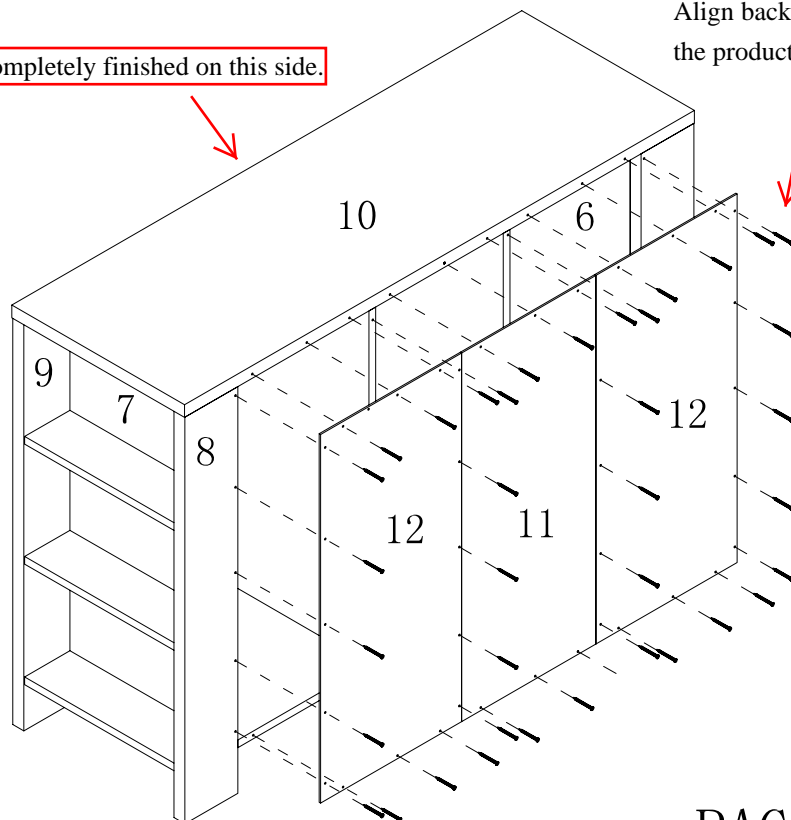

Align back panels (#11,12) to the back of the product. Secure by using nails (#H).



ASSEMBLY INSTRUCTION

Align drawer side panels (#16,17) to the drawer back panel (#18). Secure by using screws (#L).

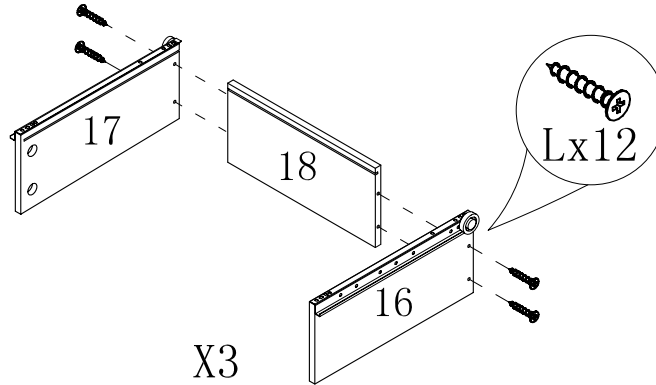

STEP7

X3

STEP8

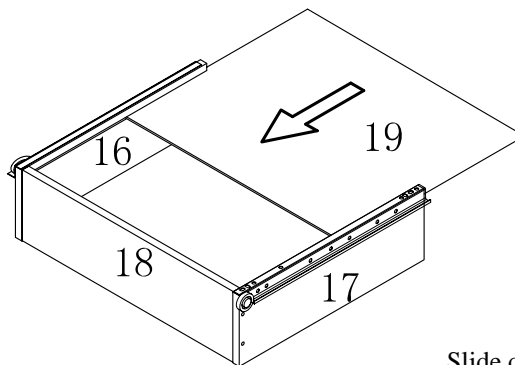

X3

Slide drawer bottom panel (#19) through the tin lines of panels (#16,17,18).

STEP9

- 1) Align and secure drawer handle (#N) to front drawer panel (#20) by using bolts (#O).
- 2) Attach cam bolts (#K) to the holes of the front drawer panel (#20). Align drawer front panel (#20) to the holes of the drawers, then secure by using cam locks (#J).

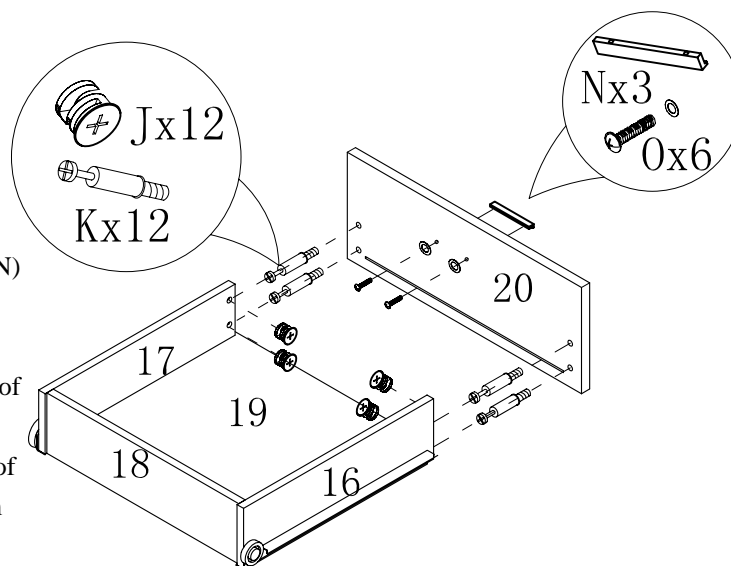

X3

PAGE: 7 OF 9

ASSEMBLY INSTRUCTION

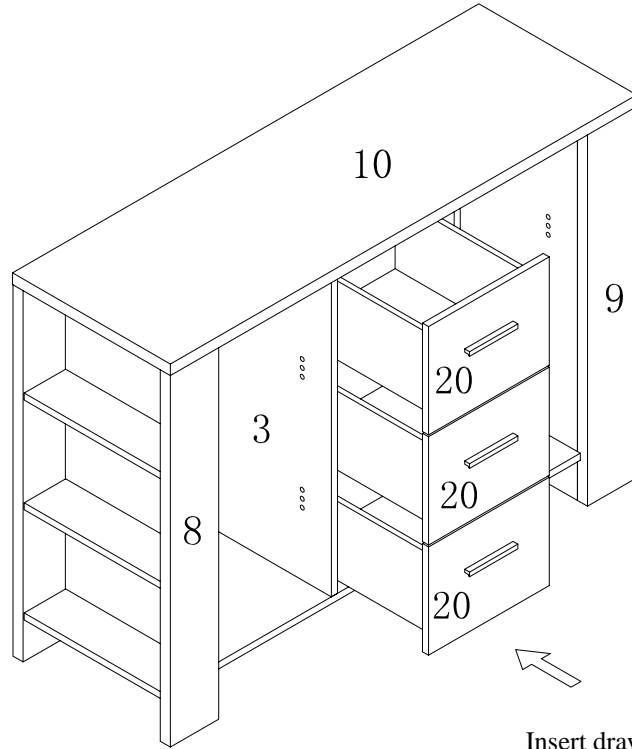

STEP 10

Insert drawers.

STEP 11

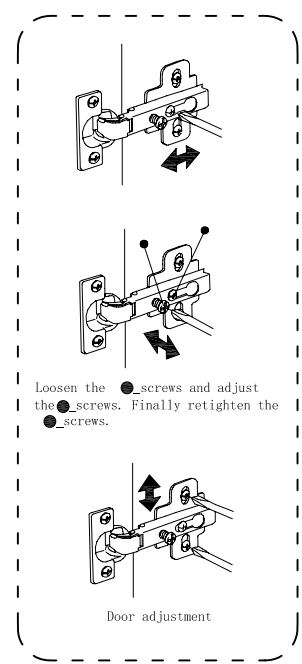
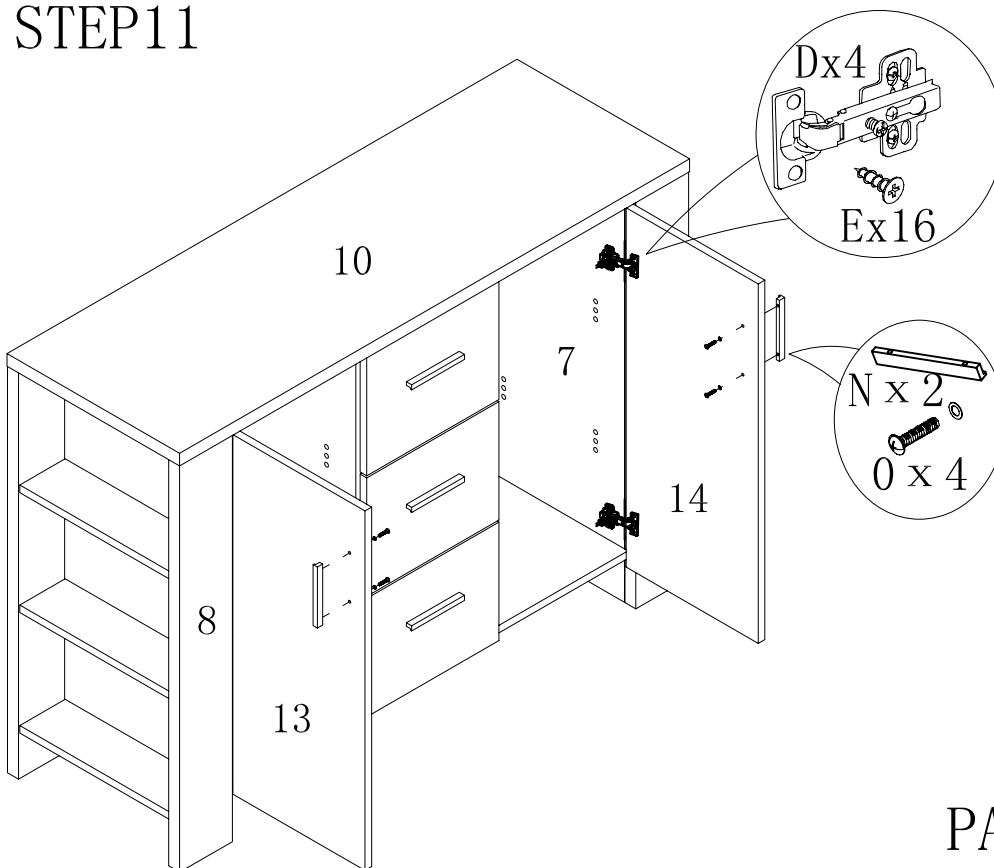

Loosen the ● screws and adjust the ● screws. Finally retighten the ● screws.

