

Assembly Instructions

Caution : You must read this before you proceed

CHAIR

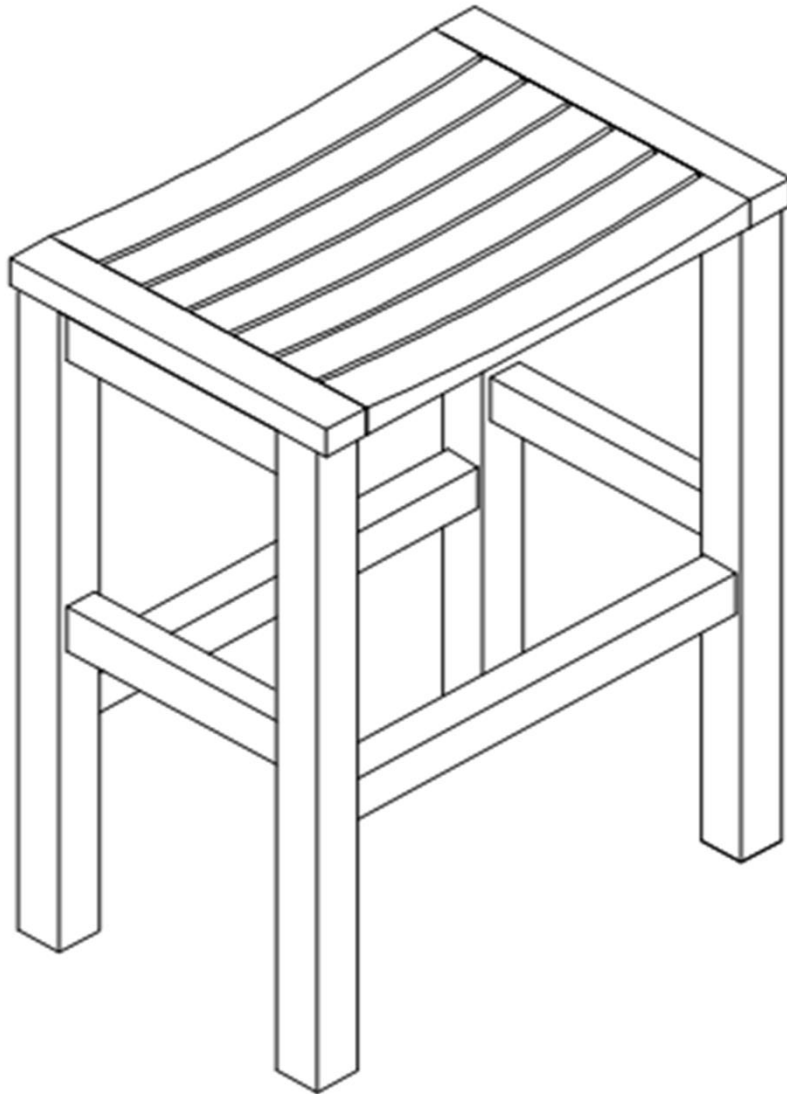

CAUTION : This Chair is NOT a TOY.



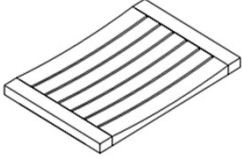
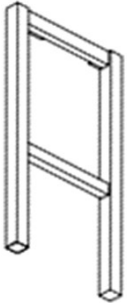
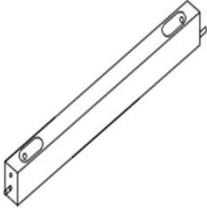

Keep your child / children at bay during the assembly process.

For moving the Chair and to prevent damage to the Chair, two adults are needed to execute this action.

Parts List

Label	Picture	Description	QTY
A		Seat Frame	1
B		Legs	2
C		Cross Bar Of Legs	2

Hardware

Label	Picture	Description	QTY
①		Bolt (M6x45mm)	9
②		Washer	5
③		Screw (M6 x 55mm)	3
④		Allen key with a round head	2

Assembly Preparation

Before Beginning Assembly:

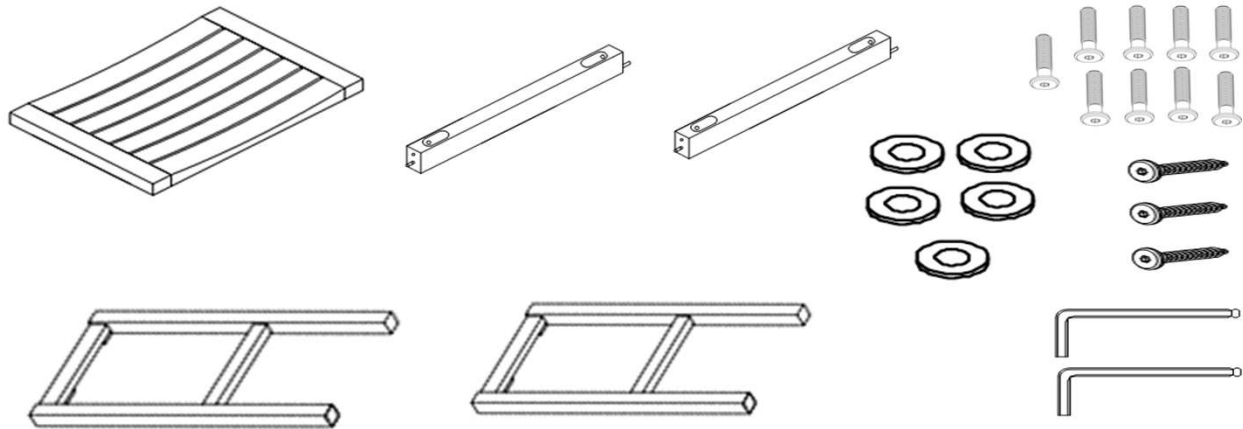

- Read instructions, cover to cover-



- Have 2 adults on hand for assembly-



- Do not assemble on flooring or carpet-



- Assemble on a clean non-marring surface (packing foam)-



- Save all packaging until finished-

Assembly Steps

OVERVIEW

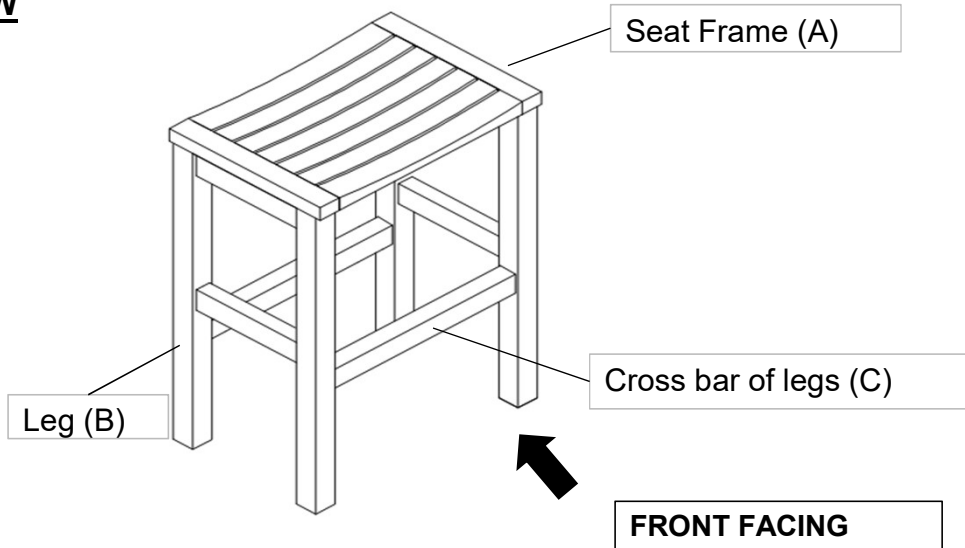

This Chair has multiple parts and may require up to some 30 minutes to assemble. To give you an overview of the Chair, the above picture is to assemble is to help you put the various parts into perspective. Please read through the instructions here below to familiarise the parts and steps before assembly.

Step 1

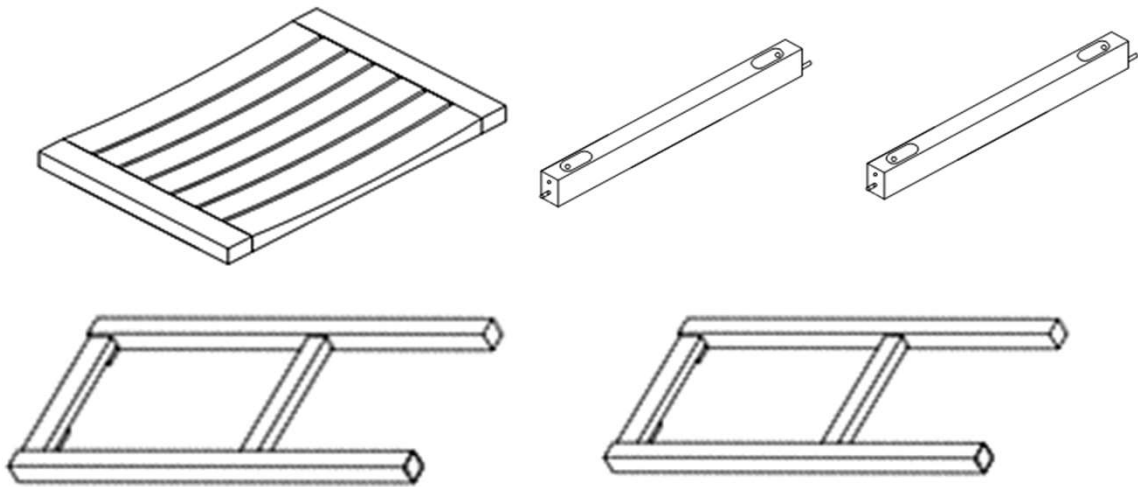

Unpack and place all parts on a clean, non-marring surface.

Step 2

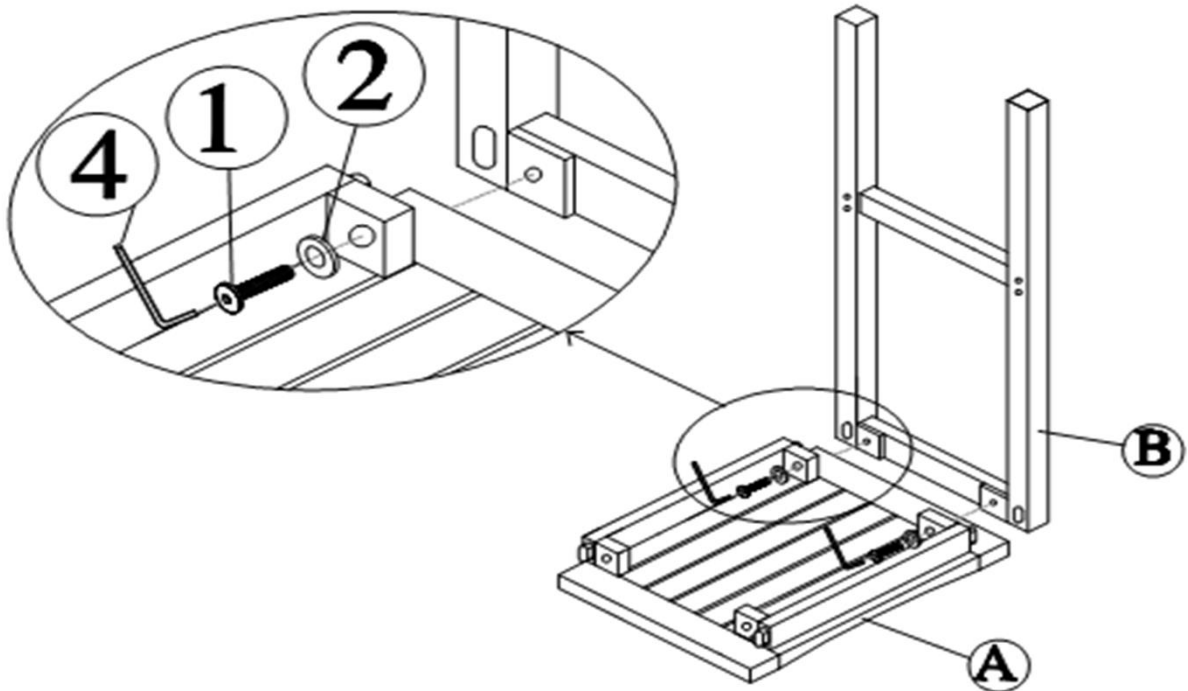

Place Seat Frame (A) with its underside skywards onto a clean, soft surface to avoid any scratch or damage to the product.

Attach Leg (B) with pre-fixed wooden dowel to the Seat Frame (A) as pictured above.

Secure by using Bolts (①), washer (②), and Allen Key (④)

DO NOT FULLY TIGHTEN THE BOLTS.

Step 3

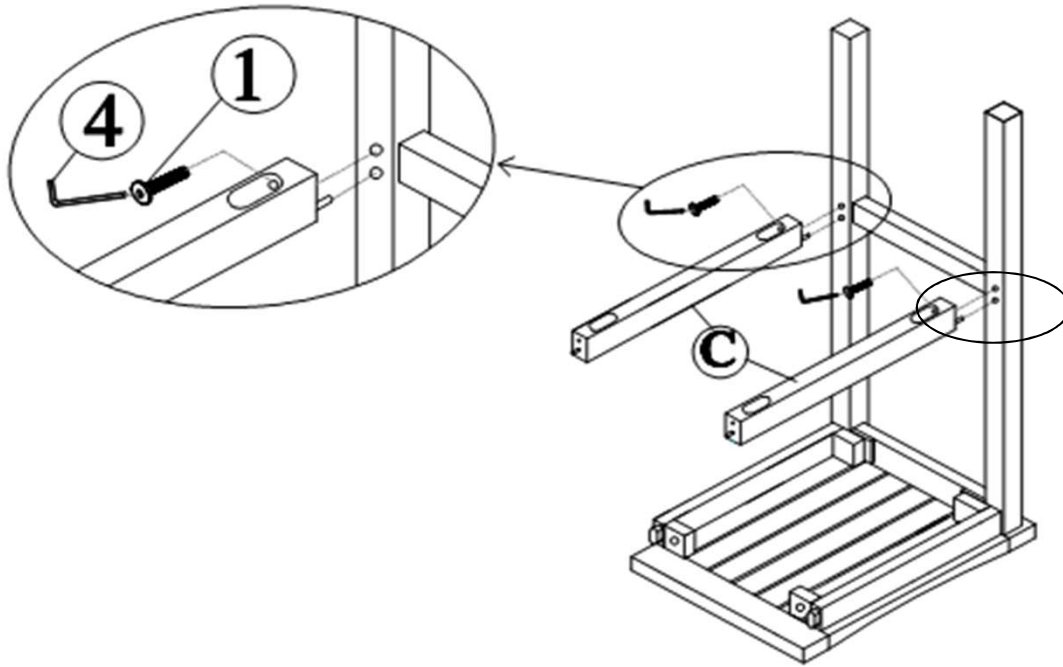

Attach the cross bars of legs (C) to in assemble part by using Bolts (①) and Allen key (④)
DO NOT FULLY TIGHTEN THE BOLTS.
FULLY TIGHTENING COULD LEAD TO DAMAGE OF THE PRODUCT.
ONLY TIGHTEN UNTIL SECURE.

Step 4

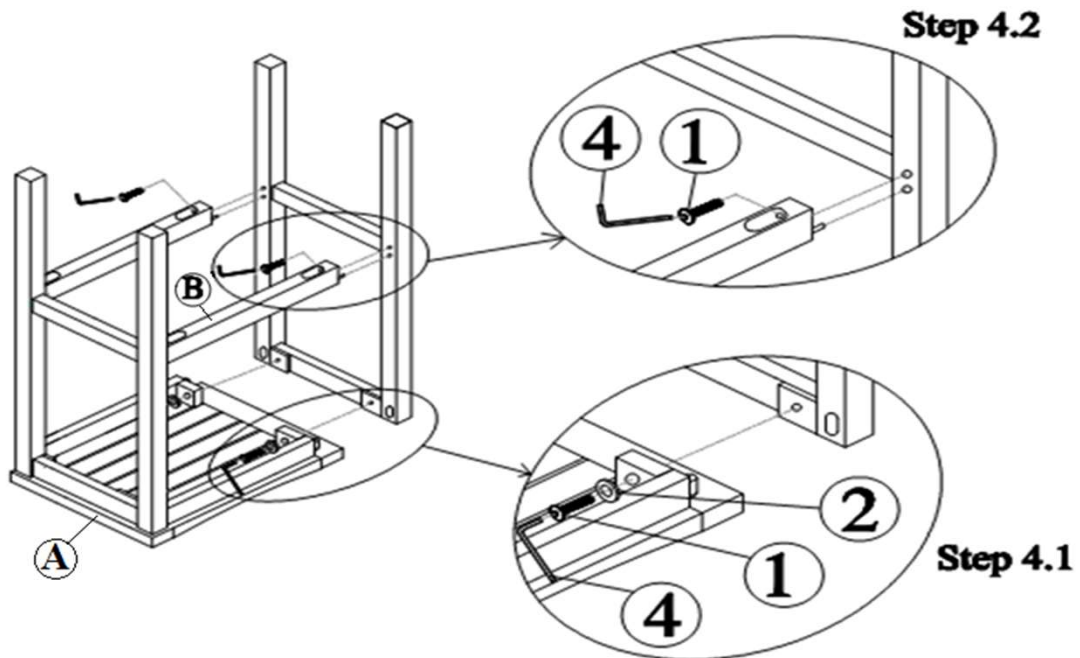

Then place complete part in step 2 into the tenon of side rails and the leg (B).

4.1 Using Bolts (①), washer (②) and Allen Key (④) to attach the seat frame (A) to the complete part in step 3.

4.2 Using Bolts (①) and Allen key (④) to attach the cross bar of leg (C) to the complete part in step 4.1.

DO NOT FULLY TIGHTEN THE BOLTS.

Step 5

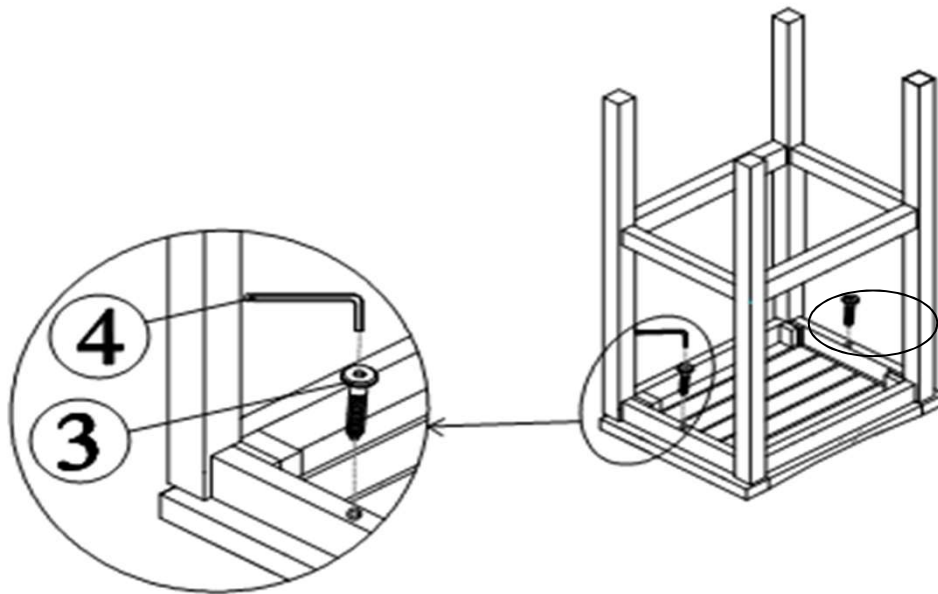

Finally, using Screw (③) and Allen key (④) to strengthen seat top Panel.
DO NOT FULLY TIGHTEN THE SCREW.

Step 6

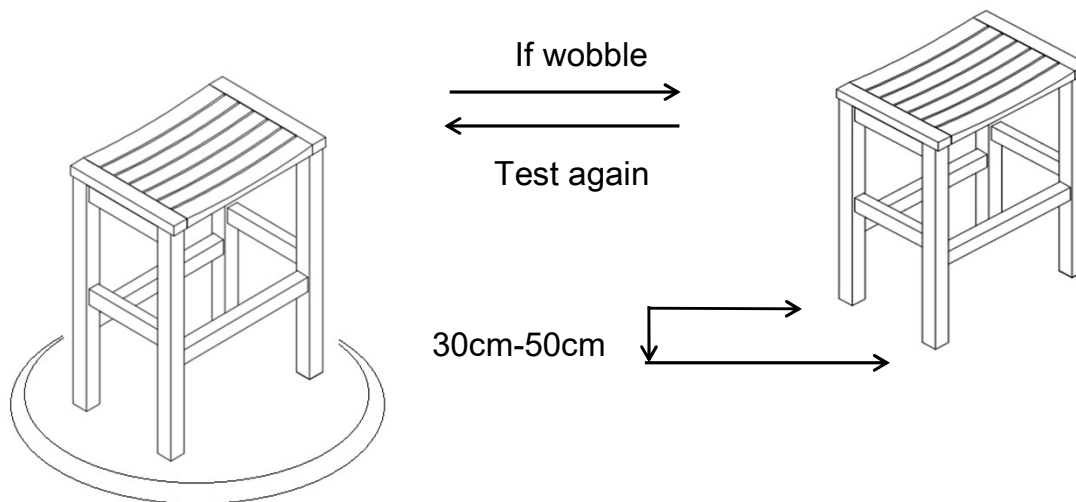

Place the Chair right side up on a **LEVEL SURFACE** to see if it wobbles.

If it wobbles, lift the Chair 30cm to 50cm high from the ground.

Keep your feet and toes well away from the drop zone.

Drop the Chair freely and vertically with all four legs, hitting the ground at the same time.

This Drop Test will help to ensure that all the Bolts and gaps reach full alignment status.

Test again for evenness on a **LEVEL SURFACE**.

If no wobbles are found, proceed to tighten all the Bolts.

When tightening the Bolts, tighten sequentially.

Do not tighten any Bolt, Screws fully and then move towards the next one.

This could cause the frame to warp.



















If there are still wobbles, loosen the Bolts and execute the same drop tests.

If the Chair is not stable it could lead to damage to the product.

Your Chair is ready for use.

This Chair can only be used on a flat, level surface.

Care & Maintenance

-   ● Do not put hot items directly on furniture surface
 -   ● Do not clean furniture with harsh cleansers or polish.
 -   ● To obtain the longest lifespan of your outdoor products, minimizing exposure to direct sunlight is recommended.
 -   ● Children should not climb or jump on the furniture.
 -   ● Do not write on furniture without a padded barrier to protect the
 -   ● To obtain the longest lifespan of your outdoor products, avoid extended and lengthy exposure to rain, snow, and direct sunshine. Whenever possible cover the product and /or place under patio or awnings.
 -   ● Not for commercial use. For residential use only .
 -   ● Stains may be removed with mild soap solution and damp cloth.
-
-   ● Dust and pick-up spills using a clean, non-colored, lint-free cloth .

Questions & Answers about Proposition 65

• What is Proposition 65?

Proposition 65 requires businesses to provide warnings to Californians about significant exposures to chemicals that cause cancer, birth defects or other reproductive harm. These chemicals can be in the products that Californians purchase, in their homes or workplaces, or that are released into the environment. By requiring that this information be provided, Proposition 65 enables Californians to make informed decisions about their exposures to these chemicals.

Proposition 65 also prohibits California businesses from knowingly discharging significant amounts of listed chemicals into sources of drinking water.

Proposition 65 requires California to publish a list of chemicals known to cause cancer, birth defects or other reproductive harm. This list, which must be updated at least once a year, has grown to include approximately 900 chemicals since it was first published in 1987.

• What types of chemicals are on the Proposition 65 list?

The list contains a wide range of naturally occurring and synthetic chemicals that include additives or ingredients in pesticides, common household products, food, drugs, dyes, or solvents. Listed chemicals may also be used in manufacturing and construction, or they may be byproducts of chemical processes, such as motor vehicle exhaust.

• What does a warning mean?

If a warning is placed on a product label or posted or distributed at a workplace, a business, or in rental housing, the business issuing the warning is aware or believes that it is exposing individuals to one or more listed chemicals.

By law, a warning must be given for listed chemicals unless the exposure is low enough to pose no significant risk of cancer or is significantly below levels observed to cause birth defects or other reproductive harm.

• Where can I get more information on Proposition 65?

If you have specific questions on the administration or implementation of Proposition 65, you can contact OEHHA's Proposition 65 program at P65.Questions@oehha.ca.gov, or by phone at (916) 445-6900.