

ASSEMBLY INSTRUCTION

▽ PARTSxQTY

▽ ASSEMBLY PROGRAM

- ① Note: Screw F first locks about 70% to facilitate the assembly of D.

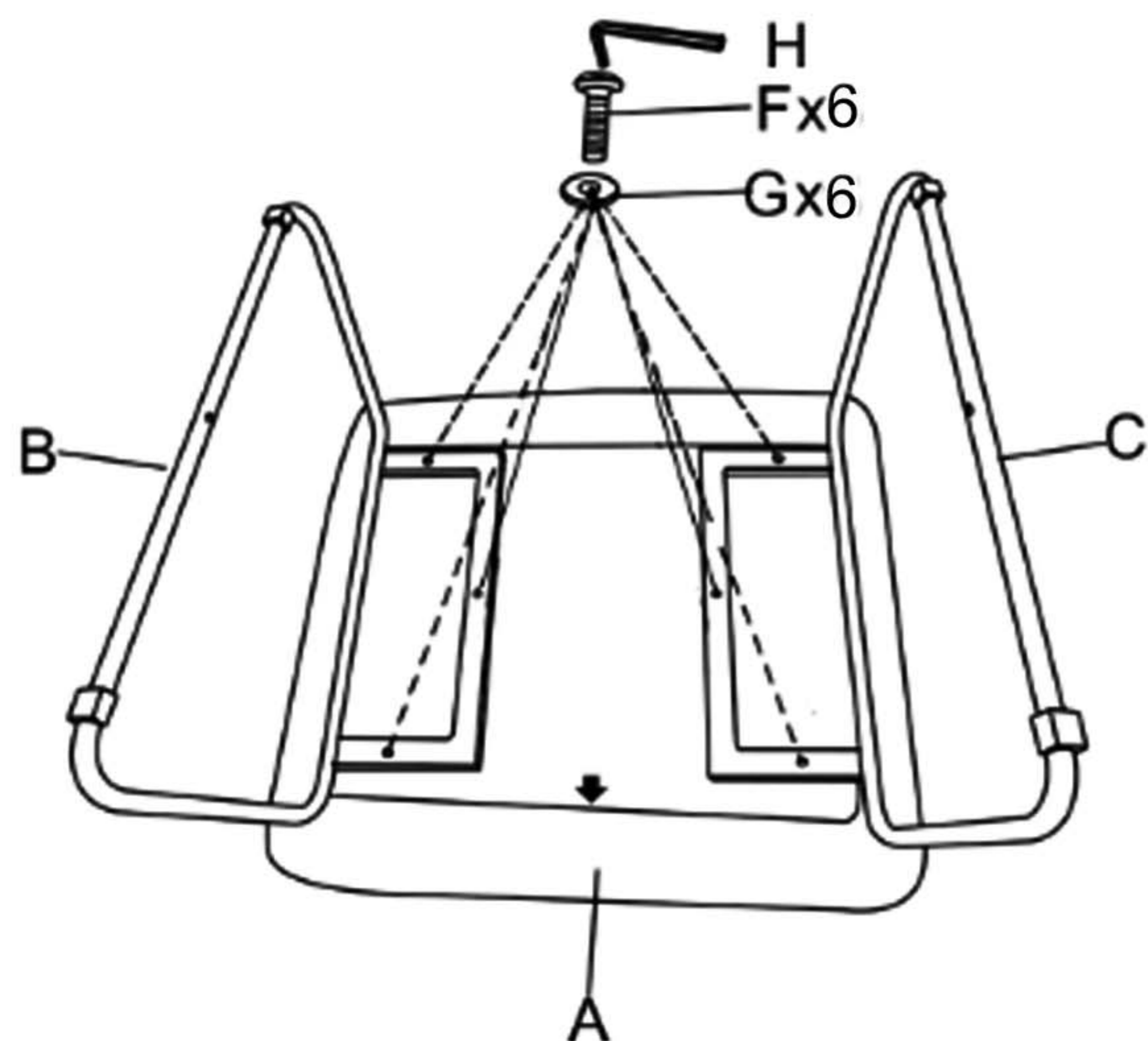



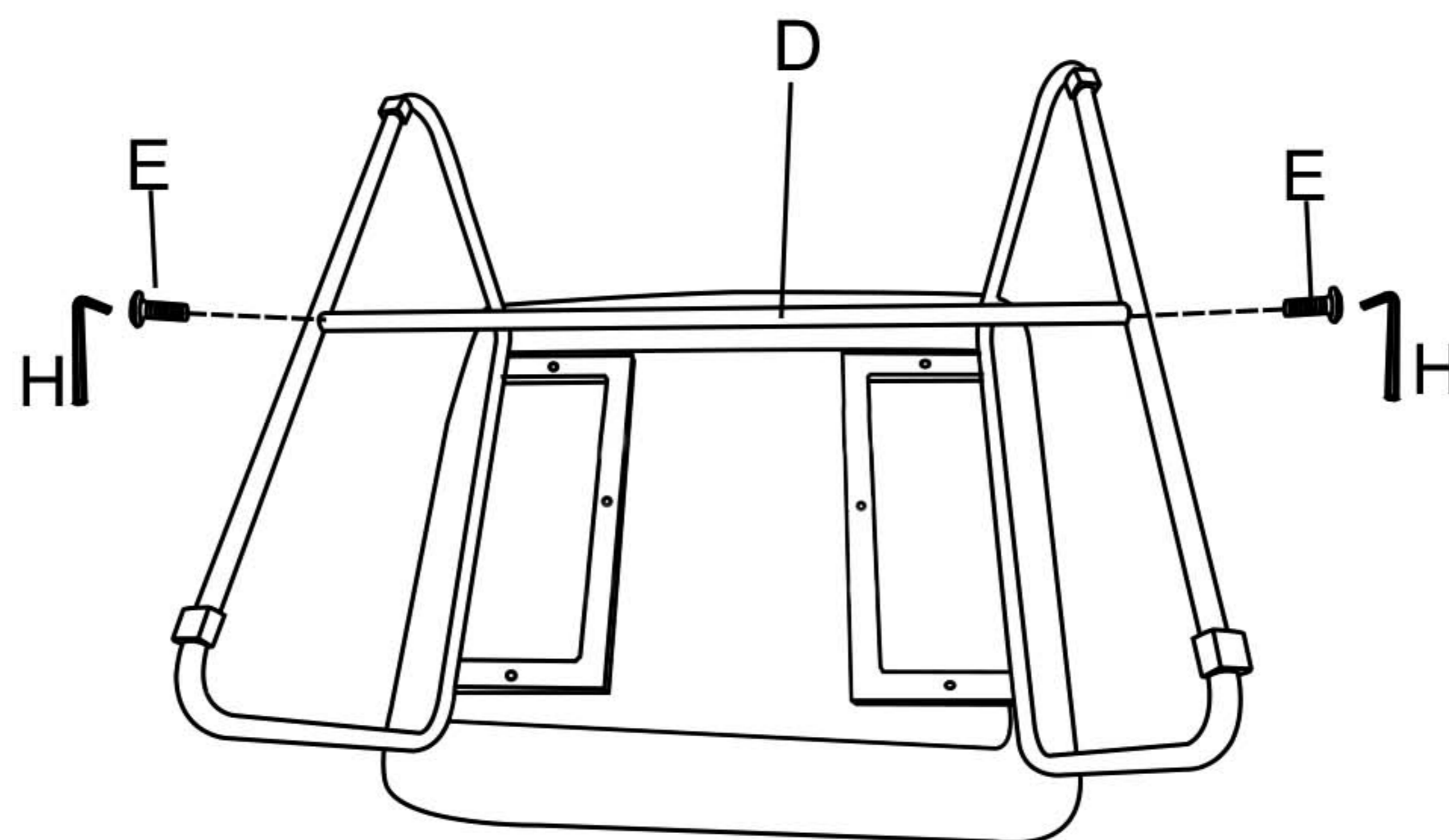

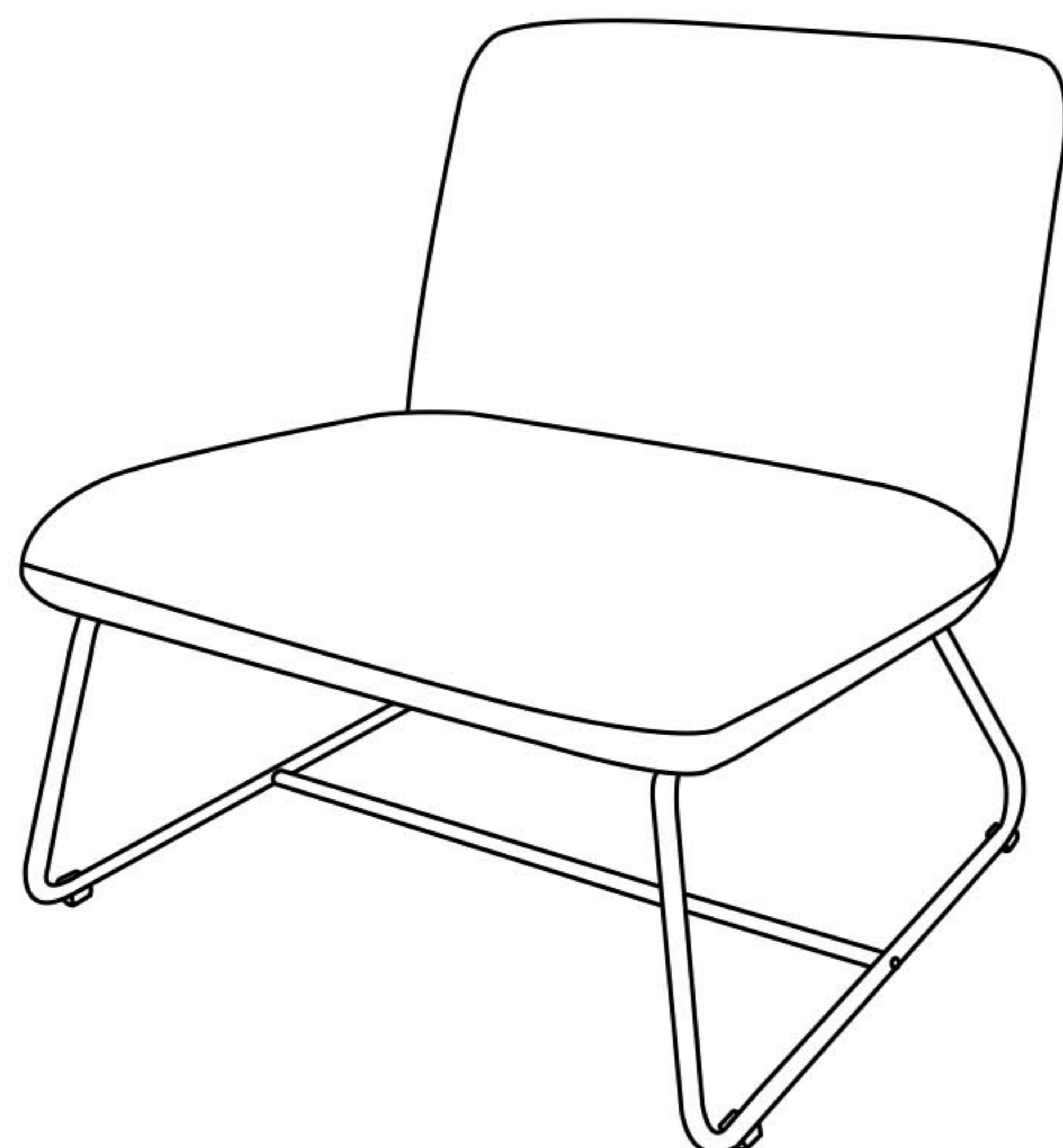

- ②
1. Assemble D first.
 2. Lock all screws E and F 100%.

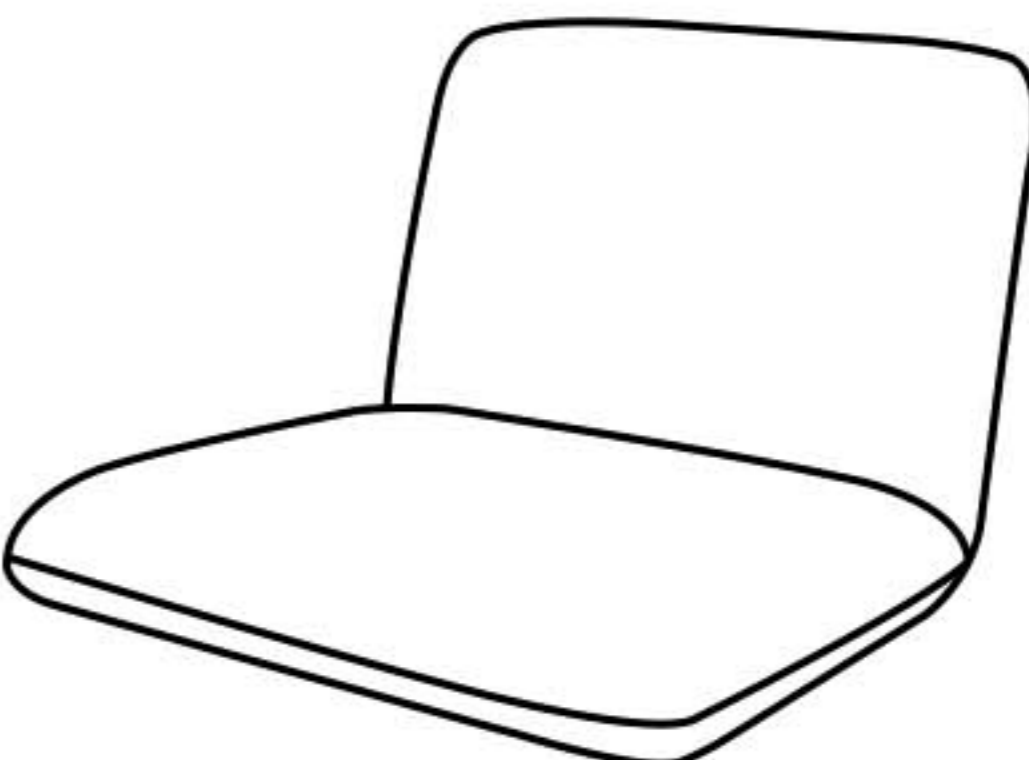

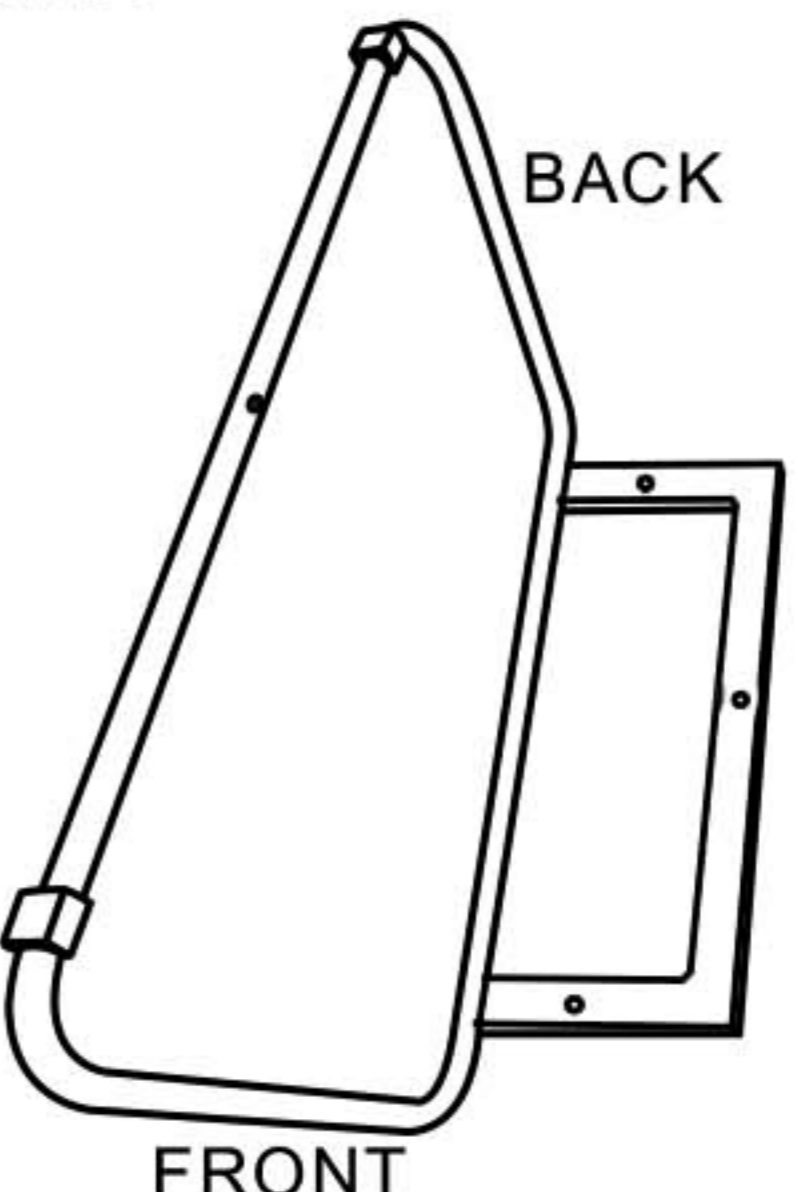
③

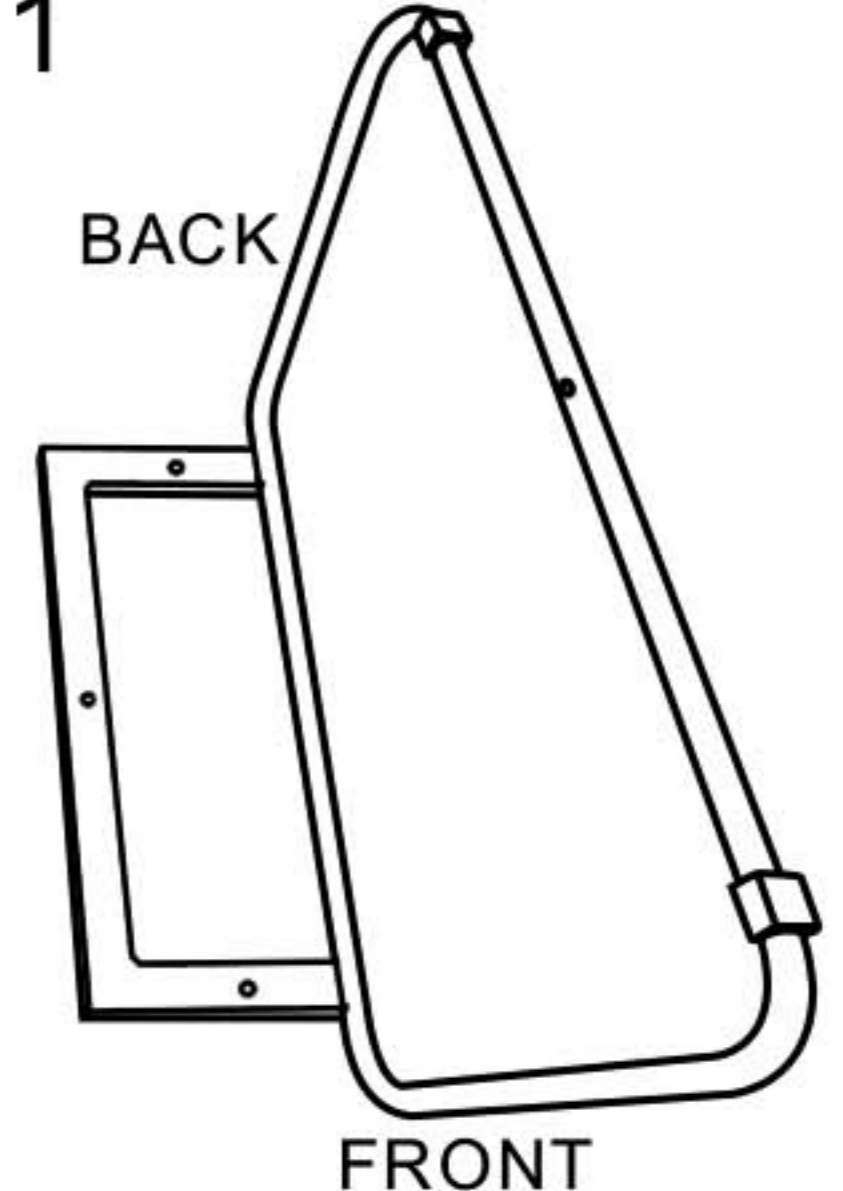

AX1 	Ex2  M6x25mm
Bx1 	Fx6  M6x35mm
Cx1 	Gx6 
Dx1 	Hx1 